

---

**Motion Control Engineering, Inc.  
11380 White Rock Road  
Rancho Cordova, CA 95742**

voice 916 463 9200  
fax 916 463 9201  
[www.mceinc.com](http://www.mceinc.com)

## **Motion 2000 Hydraulic Controller User Guide**

---

## **Copyright**

© 2011, Motion Control Engineering. All Rights Reserved.

This document may not be reproduced, electronically or mechanically, in whole or in part, without written permission from Motion Control Engineering.

## **Trademarks**

All trademarks or registered product names appearing in this document are the exclusive property of the respective owners.

## **Warning and Disclaimer**

Although every effort has been made to make this document as complete and accurate as possible, Motion Control Engineering and the document authors, publishers, distributors, and representatives have neither liability nor responsibility for any loss or damage arising from information contained in this document or from informational errors or omissions. Information contained in this document shall not be deemed to constitute a commitment to provide service, equipment, or software by Motion Control Engineering or the document authors, publishers, distributors, or representatives.

## **Limited Warranty**

Motion Control Engineering (manufacturer) warrants its products for a period of 15 months from the date of shipment from its factory to be free from defects in workmanship and materials. Any defect appearing more than 15 months from the date of shipment from the factory shall be deemed to be due to ordinary wear and tear. Manufacturer, however, assumes no risk or liability for results of the use of the products purchased from it, including, but without limiting the generality of the forgoing: (1) The use in combination with any electrical or electronic components, circuits, systems, assemblies or any other material or equipment (2) Unsuitability of this product for use in any circuit, assembly or environment. Purchasers' rights under this warranty shall consist solely of requiring the manufacturer to repair, or in manufacturer's sole discretion, replace free of charge, F.O.B. factory, any defective items received at said factory within the said 15 months and determined by manufacturer to be defective. The giving of or failure to give any advice or recommendation by manufacturer shall not constitute any warranty by or impose any liability upon the manufacturer. This warranty constitutes the sole and exclusive remedy of the purchaser and the exclusive liability of the manufacturer, AND IN LIEU OF ANY AND ALL OTHER WARRANTIES, EXPRESSED, IMPLIED, OR STATUTORY AS TO MERCHANTABILITY, FITNESS, FOR PURPOSE SOLD, DESCRIPTION, QUALITY PRODUCTIVENESS OR ANY OTHER MATTER. In no event will the manufacturer be liable for special or consequential damages or for delay in performance of this warranty.

Products that are not manufactured by MCE (such as drives, CRTs, modems, printers, etc.) are not covered under the above warranty terms. MCE, however, extends the same warranty terms that the original manufacturer of such equipment provide with their product (refer to the warranty terms for such products in their respective manual).

---

## **End User License Agreement**

This End User License Agreement (“Agreement”) grants you the right to use the software contained in this product (the “Software”) subject to the following restrictions: You may not: (i) copy the Software, except for archive purposes consistent with your standard archive procedures; (ii) transfer the Software to a third party apart from the entire product; (iii) modify, decompile, disassemble, reverse engineer or otherwise attempt to derive the source code of the Software; (iv) export the Software or underlying technology in contravention of applicable U.S. and foreign export laws and regulations; and (v) use the Software other than in connection with operation of the product.

“LICENSOR'S SUPPLIERS DO NOT MAKE OR PASS ON TO END USER OR ANY OTHER THIRD PARTY, ANY EXPRESS, IMPLIED OR STATUTORY WARRANTY OR REPRESENTATION ON BEHALF OF SUCH SUPPLIERS, INCLUDING BUT NOT LIMITED TO THE IMPLIED WARRANTIES OF NON-INFRINGEMENT, TITLE, MERCHANTABILITY OR FITNESS FOR A PARTICULAR PURPOSE.”

---

## Important Precautions and Useful Information

This preface contains information that will help you understand and safely maintain MCE equipment. We strongly recommend you review this preface and read this manual before installing, adjusting, or maintaining Motion Control Engineering equipment. This preface discusses:

- Safety and Other Symbol Meanings
- Safety Precautions
- [Environmental Considerations](#)
- [In this Manual](#)

## Safety and Other Symbol Meanings



### Danger

This manual symbol is used to alert you to procedures, instructions, or situations which, if not done properly, might result in personal injury or substantial equipment damage.



### Caution

This manual symbol is used to alert you to procedures, instructions, or situations which, if not done properly, might result in equipment damage.



### Note

This manual symbol is used to alert you to instructions or other immediately helpful information.

## Safety Precautions



### Danger

This equipment is designed to comply with ASME A17.1, National Electrical Code, CE, and CAN/CSA-B44.1/ASME-A17.5 and must be installed by a qualified contractor. It is the responsibility of the contractor to make sure that the final installation complies with all local codes and is installed in a safe manner.

This equipment is suitable for use on a circuit capable of delivering not more than 10,000 rms symmetrical amperes, 600 volts maximum. The three-phase AC power supply to the Drive Isolation Transformer used with this equipment must originate from a fused disconnect switch or circuit breaker sized in conformance to all applicable national, state, and local electrical codes in order to provide the necessary motor branch circuit protection for the Drive Unit and motor. Incorrect motor branch circuit protection will void the warranty and may create a hazardous condition.

---

Proper grounding is vitally important to safe and successful operation. Bring your ground wire to the system subplate. You must choose the proper conductor size and minimize the resistance to ground by using the shortest possible routing. See National Electrical Code Article 250-95 or the applicable local electrical code.

Before applying power to the controller, physically check all the power resistors and other components located in the resistor cabinet and inside the controller. Components loosened during shipment may cause damage.

For proper operation of your controller, you must make sure that: 1) A direct solid ground is provided in the machine room to properly ground the controller and motor. Indirect grounds such as the building structure or a water pipe may not provide proper grounding and could act as an antenna to radiate RFI noise, thus disturbing sensitive equipment in the building. Improper grounding may also render any RFI filter ineffective. 2) The incoming power to the controller and the outgoing power wires to the motor are in their respective, separate, grounded conduits.

This equipment may contain voltages as high as 1000 volts. Use extreme caution. Do not touch any components, resistors, circuit boards, power devices, or electrical connections without ensuring that high voltage is not present.

## Environmental Considerations

- Keep the machine room clean.
- Controllers are generally in NEMA 1 enclosures.
- Do not install the controller in a dusty area.
- Do not install the controller in a carpeted area.
- Keep room temperature between 32 and 104 degrees F (0 to 40 degrees C).
- Prevent condensation on the equipment.
- Do not install the controller in a hazardous location or where excessive amounts of vapors or chemical fumes may be present.
- Make certain that power line fluctuations are within plus or minus 10% of proper value.

## Air Conditioned Equipment Cabinets

If your control or group enclosure is equipped with an air conditioning unit, it is very important to observe the following precautions. (Failure to do so can result in moisture damage to electrical components.)

- Maintain the integrity of the cabinet by using sealed knockouts and sealing any holes made during installation.
- Do not run the air conditioning while the cabinet doors are open.
- If you turn the air conditioner off while it is running, wait at least five minutes before restarting it. Otherwise, the compressor may be damaged.
- Observe the recommended thermostat setting (75 degrees) and follow recommended maintenance schedules.
- Make certain that the air conditioning drain tube remains clear to avoid water accumulation in the unit.

---

## In This Manual:

This manual is the installation, adjustment, and troubleshooting guide for the HMC-2000 car control. When viewed online as a pdf file, hyperlinks (buttons or blue text) link to related topics and informational websites. The manual includes:

- [Contents](#): Table of Contents. When viewed online as a pdf file, hyperlinks in the Contents link to the associated topic in the body of the manual.
- [Section 1](#). Motion 2000 Description: A description of the Motion 2000 controller and circuit boards.
- [Section 2](#). Installation: Installation and wiring guidelines.
- [Section 3](#). Startup - Inspection Operation: Controller startup, operation on Inspection, installation of hoistway equipment and preparing the car to run on Test/Normal operation.
- [Section 4](#). Final Adjustment: A description of absolute floor encoding and Test mode operation. Running the car on Test and Normal operation and making the final checks and adjustments prior to releasing the car to normal operation.
- [Section 5](#). The Computer: How to use the MPU to program and troubleshoot the controller. Complete with parameter definitions where appropriate.
- [Section 6](#). Troubleshooting: This section includes Status and Error Messages, PC Board Quick References and Data Trap instructions.
- [Section 7](#). Appendix: Record of Parameter Values, Security Codes, LS-QUTE Landing System.
- [Index](#): Alphabetical index to help you find information in the manual. When viewed online as a pdf file, index entry page references are hyperlinks to the associated information in the body of the manual.



# Contents

## Section 1. Motion 2000 Description

<b>General Information</b> .....	<b>1-1</b>
<b>Car Controller Description</b> .....	<b>1-3</b>
Controller Circuit Boards .....	1-5
<b>Landing System</b> .....	<b>1-9</b>
LS-QUTE Landing System .....	1-9
LS-STAN Landing System .....	1-10
<b>Operating Mode Descriptions</b> .....	<b>1-11</b>
Automatic Operation .....	1-11
Mode Entry .....	1-11
Inspection Operation .....	1-12
Cartop Inspection .....	1-12
In Car Inspection .....	1-12
Machine Room Inspection .....	1-13
Hoistway Access Inspection .....	1-13
Attendant Service Operation .....	1-14
Mode Entry .....	1-14
Independent Service Operation .....	1-14
Mode Entry .....	1-14
Sabbath Operation .....	1-15
Emergency Medical Operation .....	1-15
Hospital Service Operation .....	1-16
Fire Service Operation .....	1-16
Emergency Power Operation .....	1-17
Generator Backup .....	1-17
EPS Backup .....	1-17
Car Recall .....	1-17
Capture for Test .....	1-18
Test Mode .....	1-18
<b>Monitoring and Control Options</b> .....	<b>1-19</b>
iMonitor .....	1-19
iReport .....	1-19
BMS-Link .....	1-20
Motion Portable Adjustment Control (mPAC) .....	1-20
mView .....	1-21

---

## Section 2. Installation

<b>In this Section</b> .....	<b>2-1</b>
<b>Safety Precautions</b> .....	<b>2-2</b>
Personal Safety .....	2-2
Equipment Safety .....	2-2
<b>Installation Considerations</b> .....	<b>2-3</b>
Machine Room Preparation .....	2-3
Piping and Wiring .....	2-4
How Electrical Noise Occurs .....	2-4
How to Avoid Electrical Noise Problems .....	2-4
Possible EMI/RFI Interference .....	2-4
Recommended Tools and Test Equipment .....	2-5
Wiring Prints .....	2-5
Drawing Number Format .....	2-5
Nomenclature .....	2-6
<b>Controller Installation</b> .....	<b>2-7</b>
Controller Wiring Guidelines .....	2-7
<b>General Wiring Guidelines</b> .....	<b>2-8</b>
Proper Grounding Procedures .....	2-8
Wiring Connections for Properly Grounded Systems .....	2-8
Ground Wiring .....	2-9
Main AC Power .....	2-9
Pump Motor Wiring .....	2-9
Low Voltage Signal Wiring .....	2-10
Traveling Cable Wiring .....	2-10

## Section 3. Startup - Inspection Operation

<b>In this Section</b> .....	<b>3-1</b>
<b>Check for Shorts to Ground</b> .....	<b>3-2</b>
<b>Before Applying Power</b> .....	<b>3-2</b>
<b>Applying Power</b> .....	<b>3-3</b>
Initial Adjustments and Power Phasing .....	3-3
<b>Set Up for Construction Operation</b> .....	<b>3-4</b>
Required Connections .....	3-4
Temporary Jumpers .....	3-4
Resolving Faults .....	3-5
Temporary Run Box Hookup .....	3-5
<b>Verifying Proper Starter Operation</b> .....	<b>3-6</b>
<b>Hoistway Control Equipment Installation</b> .....	<b>3-8</b>
Installing the Landing System .....	3-8
Installing the Landing System Control Box (LS-QUTE) .....	3-8
Installing the Magnetic Strips on the Steel Tape .....	3-9
Installing the Hoistway Limit Switches .....	3-9
Door Position Monitor Switch (If used) .....	3-9



<b>Complete the Installation and Field Wiring</b> .....	<b>3-10</b>
<b>Preparing the Car to Run on Test/Normal Mode</b> .....	<b>3-11</b>

## Section 4. Final Adjustment

<b>In this Section</b> .....	<b>4-1</b>
Diagnostic Messages and Input/Output Signals .....	4-2
Onboard Diagnostics .....	4-2
Absolute Floor Encoding .....	4-2
<b>Registering Car Calls</b> .....	<b>4-3</b>
Placing Calls Using a Fused Jumper Wire .....	4-3
Test Mode Operation .....	4-4
<b>Running on Test/Normal Mode</b> .....	<b>4-5</b>
<b>Final Adjustments on Test Mode</b> .....	<b>4-6</b>
Hydraulic Valves .....	4-6
Slowdown and Limit Switches .....	4-6
Motor Limit Timer .....	4-6
Valve Limit Timer .....	4-6
Relevel Operation .....	4-6
<b>Final Adjustments on Independent Service</b> .....	<b>4-7</b>
Door Operator Adjustments .....	4-7
Door Open/Close Protection .....	4-7
Stuck Button Protection .....	4-7
<b>Final Adjustments on Normal Operation</b> .....	<b>4-8</b>
Hall Calls .....	4-8
Ride and Performance .....	4-8
Recheck .....	4-8
Options .....	4-8
Random Call Testing .....	4-8
Remote Governor Testing (Roped Hydro) .....	4-9
Static Testing: .....	4-9
Dynamic Testing: .....	4-9
<b>Release to Normal Operation</b> .....	<b>4-10</b>

## Section 5. The Computer

<b>In this Section</b> .....	<b>5-1</b>
<b>The HC-MPU Main Processor Unit</b> .....	<b>5-2</b>
Indicators .....	5-2
Switches, Buttons & Adjustments .....	5-3
Connectors .....	5-4
Status Displays .....	5-4
<b>Computer Security</b> .....	<b>5-5</b>
Password .....	5-5

<b>Diagnostic Mode</b> .....	<b>5-6</b>
Getting into Diagnostic Mode .....	5-6
Function of N Push Button .....	5-6
Function of S Push Button .....	5-6
Function of + Push Button .....	5-6
Function of - Push Button .....	5-6
Format of LCD Display .....	5-7
Troubleshooting Using the Computer's Internal Memory .....	5-9
Troubleshooting Specific Problems .....	5-12
Setting Parameters (Options) to Default Values .....	5-13
<b>F1: Program Mode</b> .....	<b>5-14</b>
General Description of Program Mode .....	5-14
Viewing Menus on the LCD Display .....	5-14
Viewing Options Within a Menu .....	5-15
Changing a Value .....	5-15
Saving the New Values .....	5-15
Restoring Original Values .....	5-15
Step-by-Step Example .....	5-16
Basic Feature Menu Options .....	5-17
Fire Service Menu Options .....	5-20
Door Operation Menu Options .....	5-22
Timer Menu Options .....	5-26
Gongs/Lanterns Menu Options .....	5-28
Spare Inputs Menu Options .....	5-29
Viewing and Assigning Spare Inputs .....	5-29
Spare Outputs Menu Options .....	5-39
Viewing and Assigning Spare Outputs .....	5-39
Extra Features Menu Options .....	5-48
Additional Car Options Menu .....	5-53
Timed Features .....	5-54
<b>F2: External Memory Mode</b> .....	<b>5-55</b>
Getting Into External Memory Mode .....	5-55
Function of N Push Button .....	5-55
Function of S Push Button .....	5-55
Function of + Push Button .....	5-55
Function of – Push Button .....	5-55
Troubleshooting Using External Memory Mode .....	5-56
<b>F3: System Mode</b> .....	<b>5-59</b>
Building Security Menu .....	5-59
Passcode Request Menu .....	5-61
Load Weigher Thresholds .....	5-62
Adjusting the Load Thresholds .....	5-62
Analog Load Weigher Learn Function .....	5-63
Controller System Menu .....	5-65
<b>F4: Messages and Floor Labels</b> .....	<b>5-66</b>
<b>F5: Controller Utilities/Monitoring and Reporting</b> .....	<b>5-67</b>
Controller Utilities Menu .....	5-67
Registering Front or Rear Car Calls .....	5-67

Date/Time .....	5-68
View Event Log .....	5-68
Clear Event Log .....	5-68
System CAN Bus Data Viewing .....	5-69
Monitoring and Reporting Menu .....	5-70
Diagnostics, Refresh, Reset .....	5-70
<b>F8: Status Displays .....</b>	<b>5-72</b>
<b>F1 &amp; F8: Board Software Versions .....</b>	<b>5-73</b>
<b>Duplexing .....</b>	<b>5-74</b>
Dispatching Algorithm .....	5-74
Hardware Connections .....	5-74
Troubleshooting .....	5-74

## Section 6. Troubleshooting

<b>In This Section .....</b>	<b>6-1</b>
<b>Troubleshooting Tools .....</b>	<b>6-2</b>
<b>Status and Error Messages .....</b>	<b>6-3</b>
<b>PC Board Quick References .....</b>	<b>6-35</b>
HC-CHP CAN Hub and Power Supply Board .....	6-36
SW1 DIP Switch Settings .....	6-37
HC-CTL Control Board .....	6-38
HC-DVR Driver Board .....	6-48
HC-MPU Main Processor Board .....	6-51
HC-MPU Battery .....	6-53
HC-RDR Rear Door Board .....	6-54
HC-UIO Universal Input/Output Board .....	6-58
Call Inputs and Outputs .....	6-59
HC-UIO DIP SW1 Switches 7, 8 and 9 Settings .....	6-60
HC-UIO Used for Calls .....	6-60
Hospital Emergency Operation I/O .....	6-60
Spare Inputs and Outputs .....	6-61
MC-CPI Car Panel Interface Board .....	6-62
Installation Instructions .....	6-62
MC-CPI Board Details .....	6-64
Before Applying Power .....	6-66
MC-LSI Landing System Interface Board .....	6-67
LSI Connections .....	6-67
SC-3HN Three Input Serial Hall Call Node Board .....	6-68
Call Bus Conditions .....	6-68
General Installation .....	6-68
Addressing and CAN Bus Termination .....	6-70
Riser Assignment .....	6-70
Floor Number and Front or Rear Opening .....	6-70
Baud Rate .....	6-70
CAN Bus Termination .....	6-70

---

On Board Diagnostics .....	6-71
ON LED .....	6-71
(FLT) FAULT LED .....	6-71
<b>Using the MLT / VLT Data Trap .....</b>	<b>6-72</b>

## Section 7. Appendix

<b>In this Section .....</b>	<b>7-1</b>
<b>Motion 2000 Parameter Settings Record .....</b>	<b>7-2</b>
Program Mode (F1) Parameter Settings Record .....	7-3
<b>Elevator Security Information and Operation .....</b>	<b>7-10</b>
Security Codes .....	7-11
<b>LS-QUTE Landing System Assembly Drawings .....</b>	<b>7-12</b>



## Quick Topics

- General Information
- Specifications
- Controller Cabinet
- Typical Layout
- Circuit Boards
- Landing System
- Operating Modes
- Monitoring Options



## Motion 2000 Description

1

### General Information

The Motion 2000 Hydraulic Elevator Control is built solidly upon the experience and desires of our customers. We began by analyzing years of comments and suggestions to be certain that we were building the controller that both installers and building owners wanted.

Motion 2000 supports simplex, duplex, or group control. Motion 2000 design achieves simple inter-connectivity and easy field expansion through CAN BUS technology, phone-style connectors and optimized field connection locations.

Motion 2000 offers the same straight-forward user interface, switch programming, and LCD display as previous generation MCE programmable controllers; no learning curve required. Motion 2000 uses multiple, redundant, self-contained processors for reliable control and consistent safety monitoring. Through the CAN BUS, each processor is continuously aware of all system activity.

An optional ethernet port supports real time connection to the following MCE products:

- iMonitor for remote monitoring and control
- iReport for current and historical performance, activity reporting and archival
- iLobby for eye-pleasing, graphic display of elevator group activity.



The job prints accompanying your Motion 2000 controller are the primary document necessary to install the controller and additional equipment (if ordered from MCE). The job prints and this manual together provide the information necessary to install, adjust, and troubleshoot the Motion 2000 elevator controller. Study the job prints and read the manual before installing and adjusting the controller. Call Motion Control Engineering with any questions you may have before beginning installation or start-up.

Your Motion 2000 system may include:

- **Car controller:** Distributed-processor, elevator control configured according to a customer job survey.
- **Car top station:** Interface/interconnect/control box between car-mounted equipment and the car controller.
- **Car top junction box:** Some jurisdictions require that circuit boards normally mounted inside the Car top station be mounted in the car controller cabinet instead. In these instances, the less complex car top junction box is used in place of the car top station.
- **Car station:** Car operating panel interface.
- **Dispatcher:** If the car is part of a group, dispatching components and software may be provided.

Motion 2000 provides:

- Low-rise hydraulic building application
- Performance up to 200 feet per minute
- Up to 32 single or double-openings
- Simplex, duplex or group control
- Extensive field programmability

<b>Motion 2000 Hydraulic Controller Specifications</b>	
Maximum car speed	200 fpm, 1.0 mps
Configuration	Simplex, Duplex, Group
Landings	Up to 32
Motor control	Solid State, Y - Delta or Across the Line
Landing system	LS-QUTE (solid tape/magnets), LS-STAN (vanes)
System access	LCD and switches, hand-held user interface or PS/2 keyboard
Dispatching	Groups to six cars
Environment	32-104°F, 0-40°C, humidity non-condensing up to 95%; harsh environment rugged service available (NEMA 4, 4X, 12)
Standard enclosure	34" w x 31.5" h x 9" d (864 x 800 x 380 mm) includes knock-outs
Optional enclosure (feature dependent)	36" w x 42" h x 9" d (914 x 1067 x 305 mm) includes knock-outs
Input	208-600 VAC, 50/60 Hz, single or 3-phase

# Car Controller Description

Motion 2000 controllers are ASME A17.1-2000 compliant. A typical Motion 2000 controller is shown below. Typical component locations are called out on the following page.

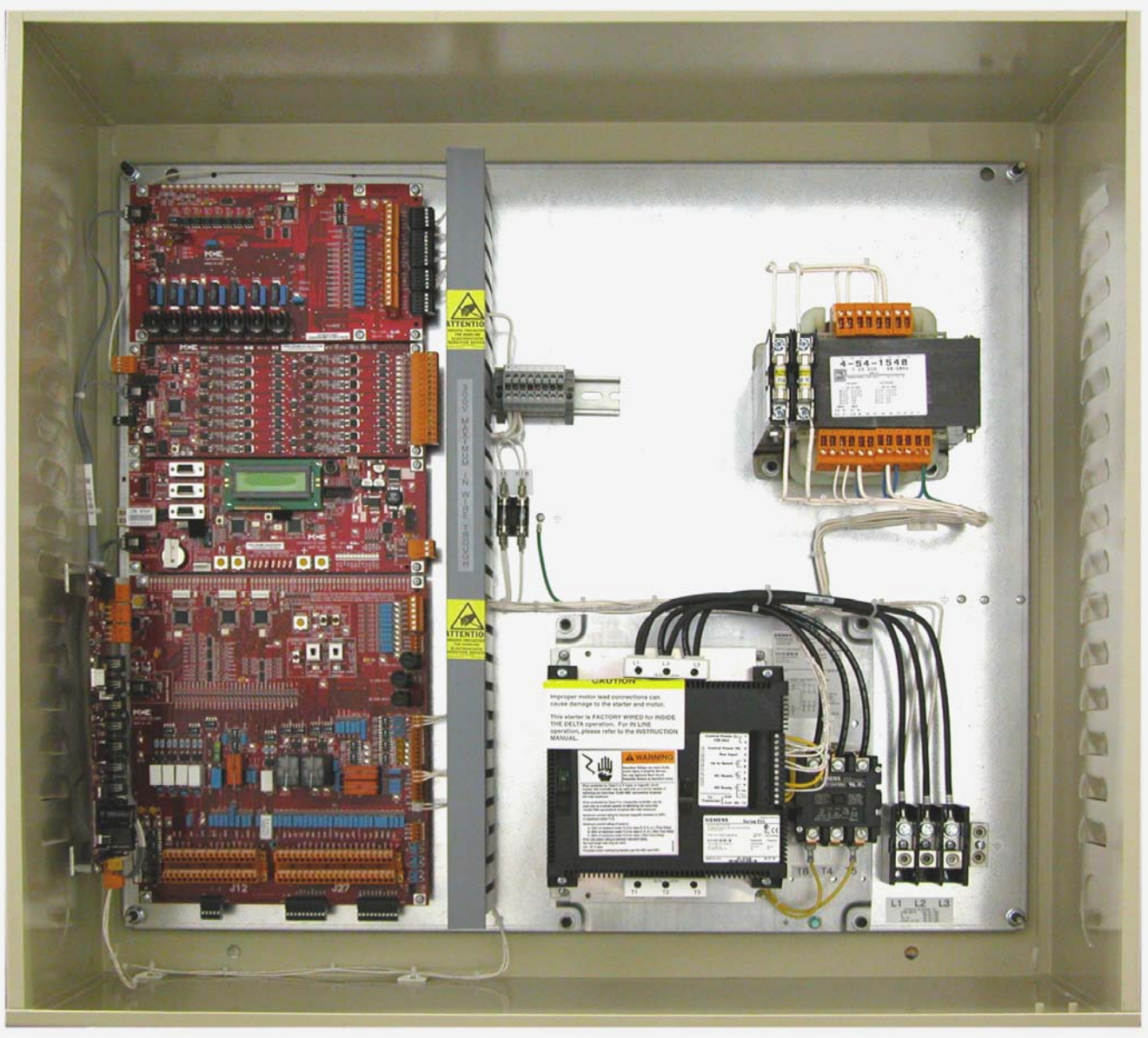

1

Figure 1.1 Typical Controller Layout

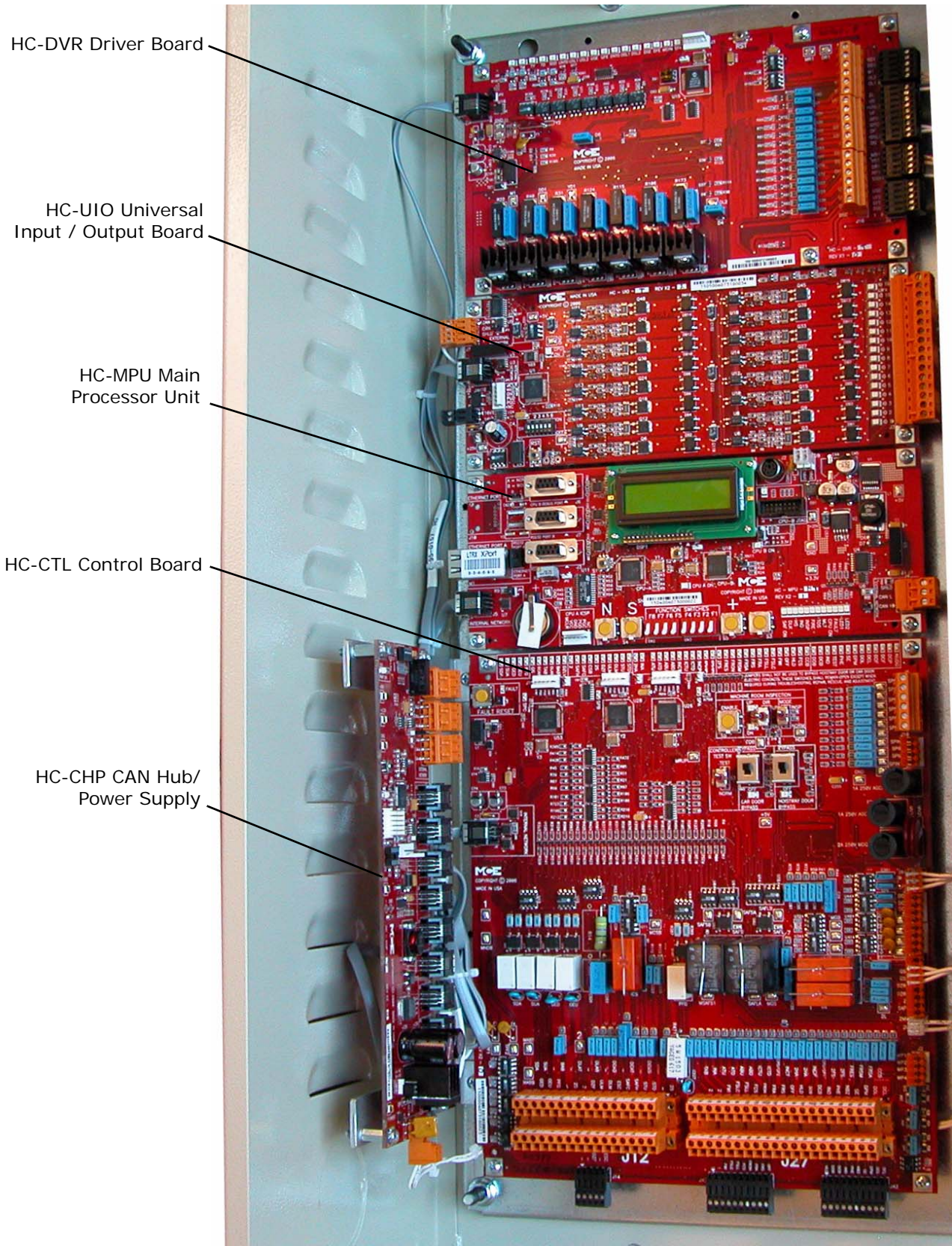



### Controller Circuit Boards

**HC-CHP, CAN Hub and Power Supply:** Provides a central connection point for the Controller Area Network (CAN). Also provides 16Vac power for digital integrated circuits throughout the controller. For more information see [“HC-CHP CAN Hub and Power Supply Board” on page 6-36.](#)

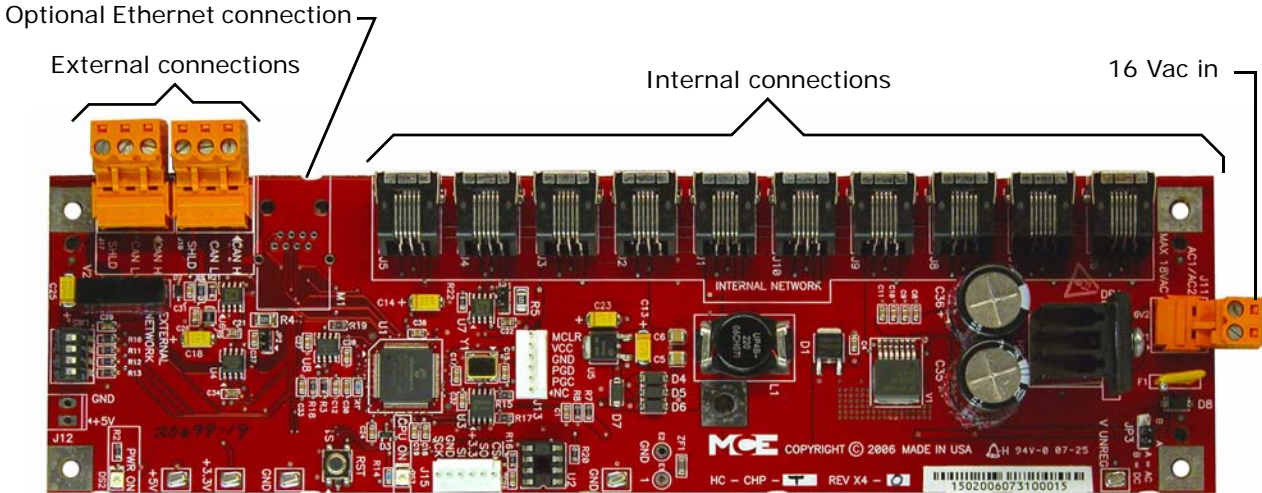

**HC-MPU Main Processor Unit** Performs control data processing. The HC-MPU is responsible for car operation, car communication, programming and diagnostics, redundancy monitoring, system software validation and duplexing. For more information see [“HC-MPU Main Processor Board” on page 6-51.](#)

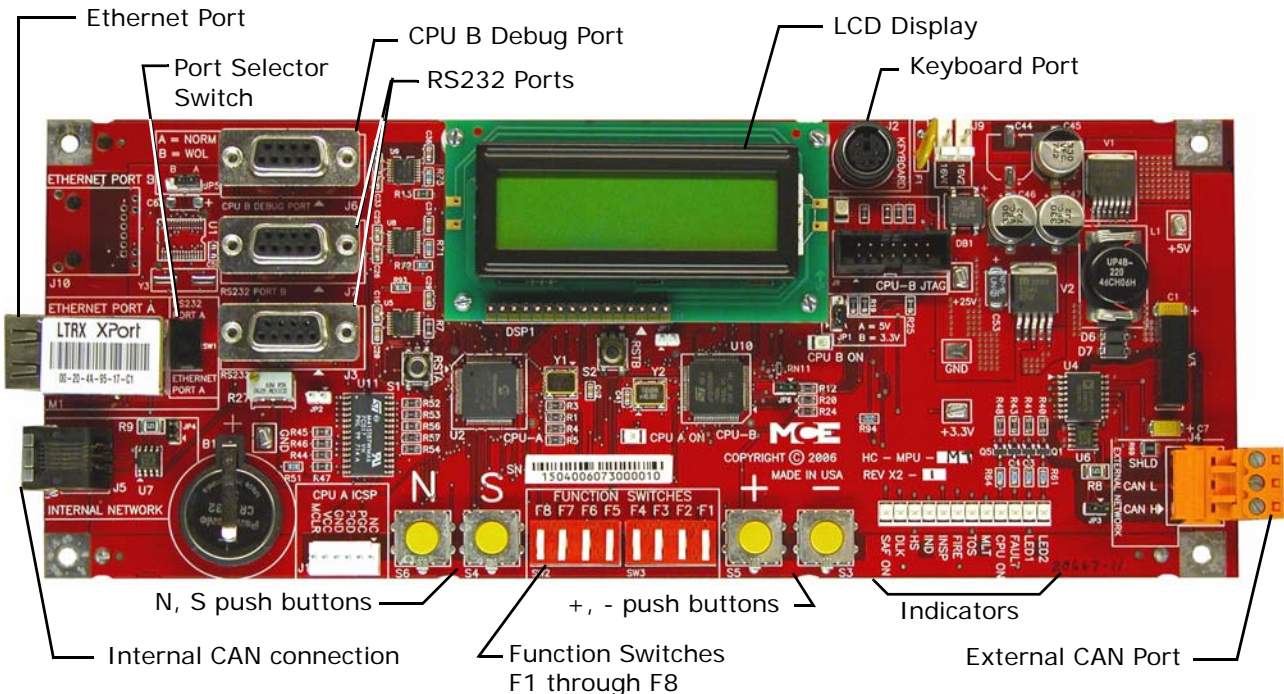



**HC-UIO Universal Input/Output Board** Depending upon the board configuration, HC-UIO boards may be used for programmable inputs and outputs (16 per board), car and hall calls, and dispatching. In all cases, the functionality of the HC-UIO board can be expanded by “plugging in” additional boards. For more information see [“HC-UIO Universal Input/Output Board” on page 6-58.](#)

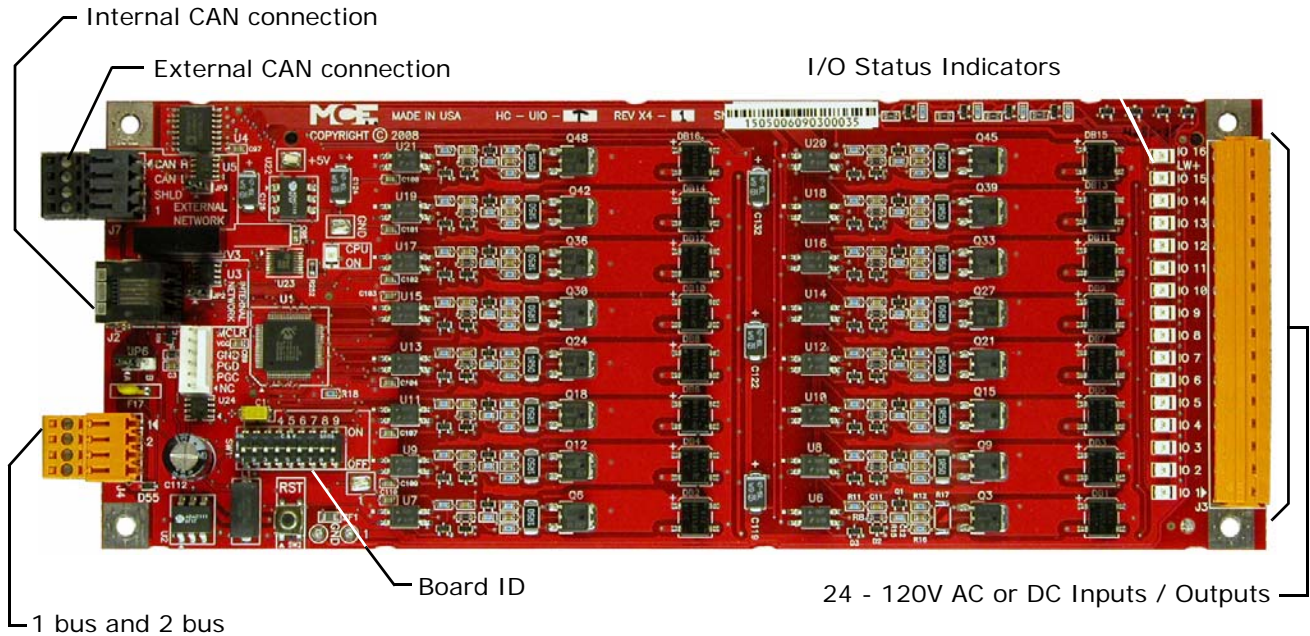

**HC-DVR Driver Board** The HC- DVR Driver board controls the starter and valves. For more information see [“HC-DVR Driver Board” on page 6-48.](#)

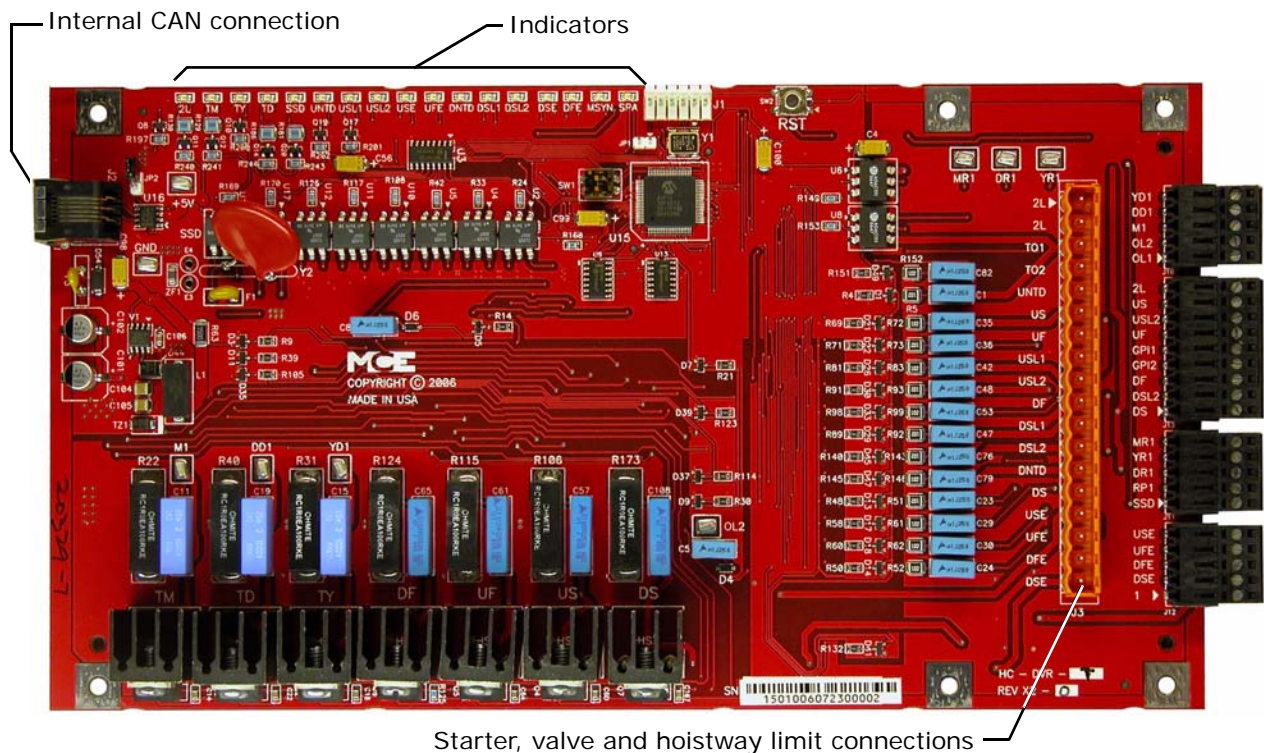

HC-CTL Main Control Board

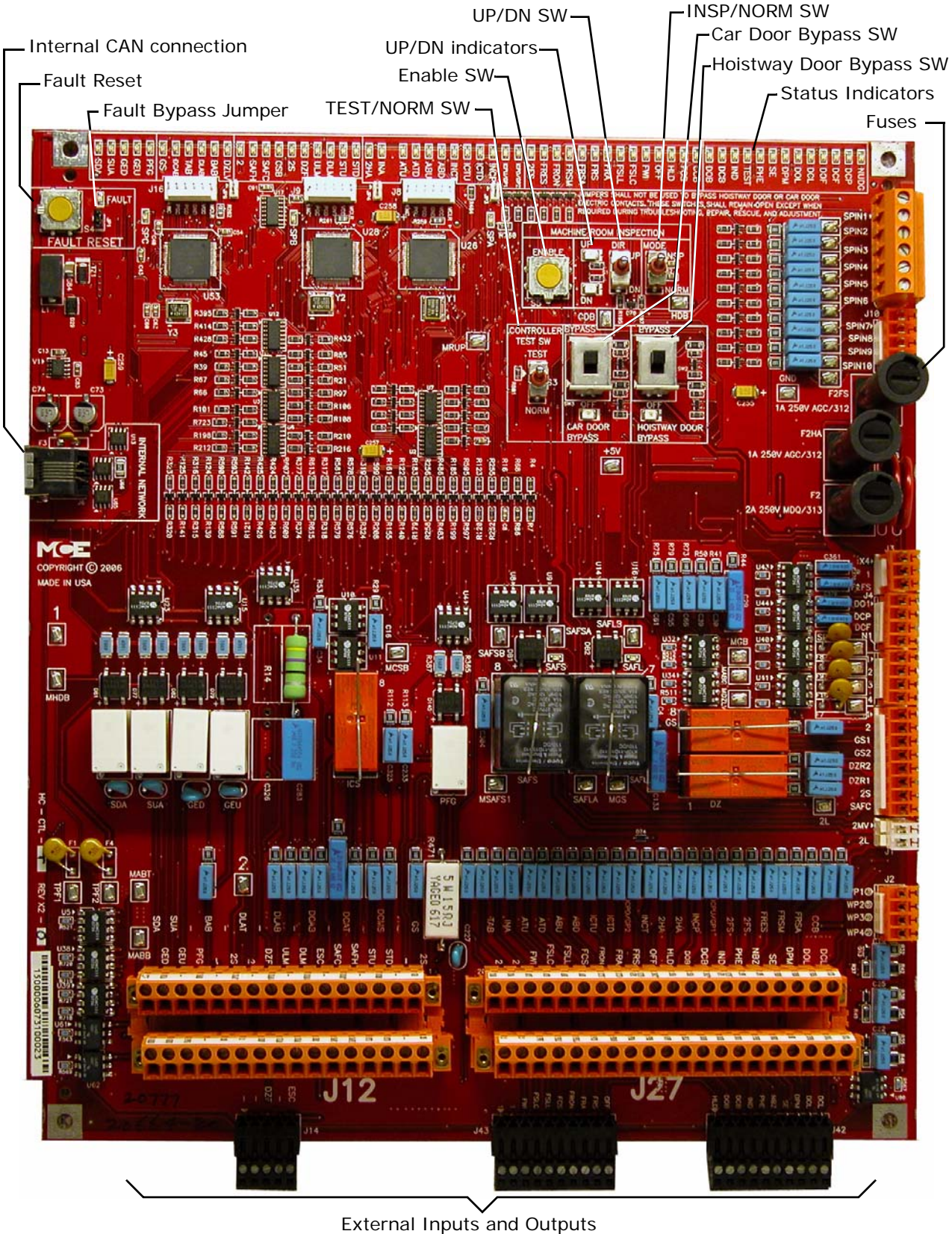

1



**HC-CTL Main Control Board** Monitors I/O, performs safety functions and front door operation. Please refer to “HC-CTL Main Control Board” on page 1-7. The HC-CTL board is responsible for inspection, fire service, landing system, door lock bypass and lanterns and gongs. For more information see “HC-CTL Control Board” on page 6-38.

**HC-RDR Rear Door Board** Provides rear door operator interface. For more information see “HC-RDR Rear Door Board” on page 6-54.

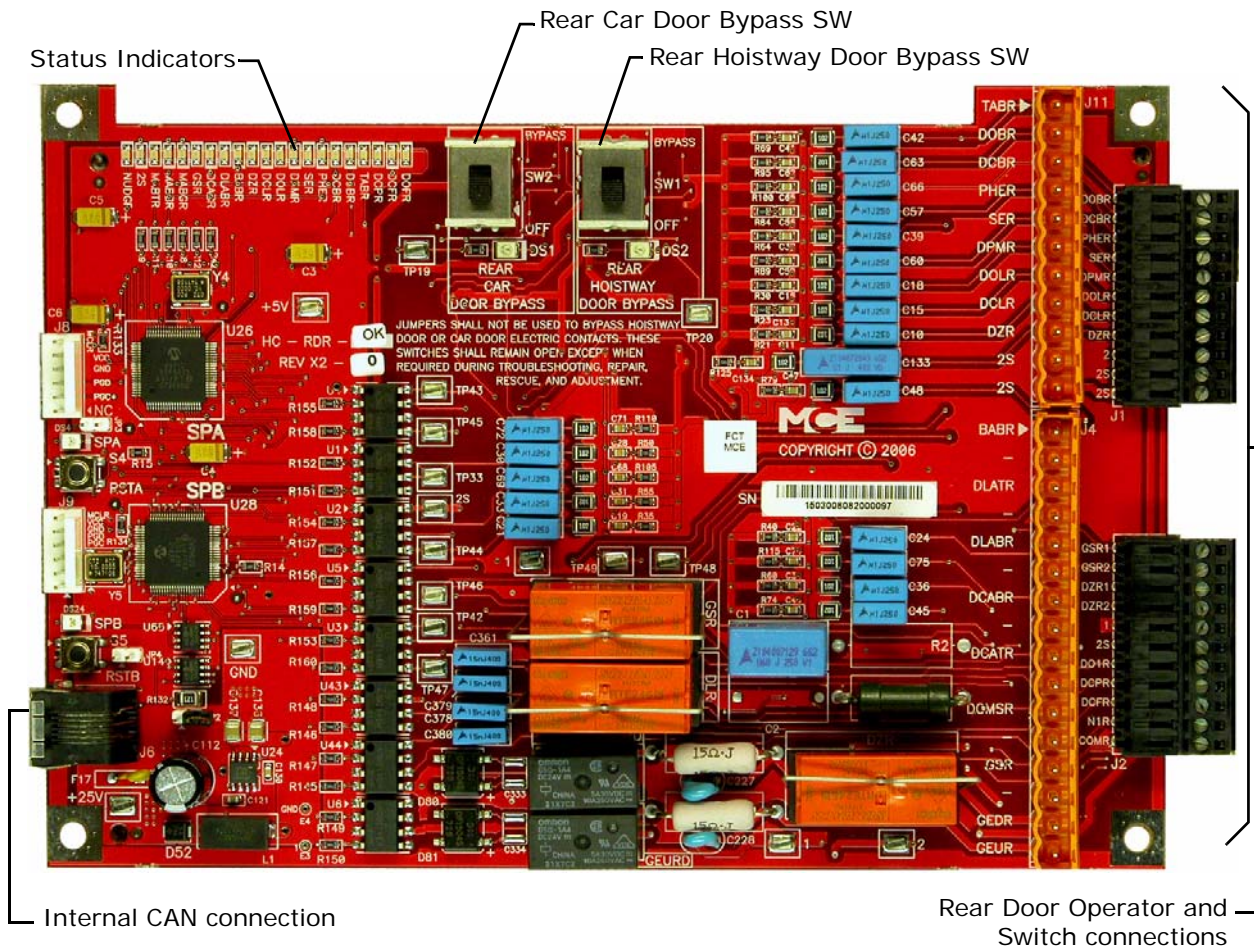

**CE Fixture boards with LON interface** (not shown) Used when extensive external fixtures are required.

**MC-CPI Car Panel Interface Board** (not shown) Converts the Discrete closures from car panel buttons and switches to CAN data and passes it through the Landing System Interface board (MC-LSI) to the car controller or dispatcher (see “MC-CPI Car Panel Interface Board” on page 6-62).

**MC-LSI Landing System Interface Board** (not shown) Provides a connection point for the Car Panel Interface board (MC-CPI). A shielded external CAN connection runs from the MC-LSI board, through the traveler, to the Motion 2000 controller (see “Example: MC-CPI Wiring” on page 6-65).

## Landing System

The landing system is designed to be mounted on the car top. The landing systems used with the Motion 2000 controller is the LS-QUTE.

### LS-QUTE Landing System

The LS-QUTE is a tape-and-magnet-operated landing system. A three inch wide steel tape is mounted in the hoistway. The cartop control box has a floating head that slides on the steel tape, and magnetic sensors for slowdown, STU, STD, ISTU, ISTD, ULM(LU), DLM(LD) and DZ. The Motion 2000 is configured for absolute floor encoding.

Figure 1.2 LS-QUTE Landing System

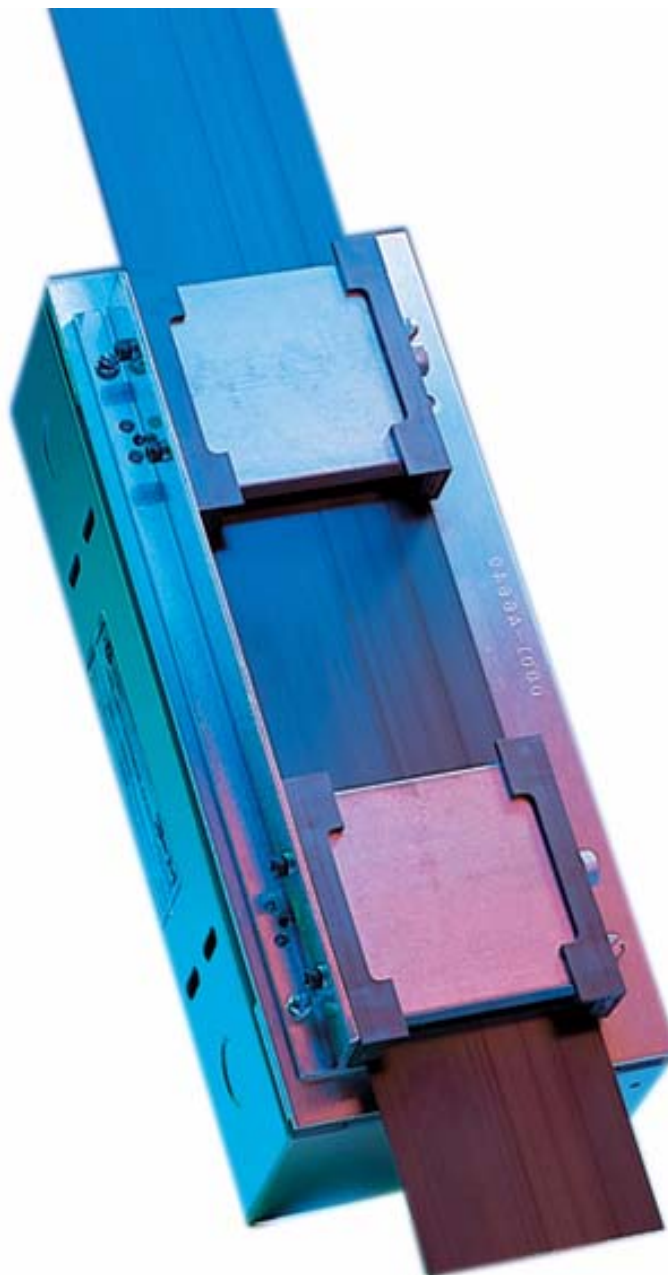

## LS-STAN Landing System

The LS-STAN landing system uses VS-1A infrared proximity switches to sense vanes that are mounted in the hoistway.

Figure 1.3 LS-STAN Landing System



## Operating Mode Descriptions

Available operating modes are configured when the car is installed. Not all modes are available on all cars. This section describes controller operating modes, including:

- Automatic Operation
- [Inspection Operation](#)
- [Attendant Service Operation](#)
- [Independent Service Operation](#)
- [Sabbath Operation](#)
- [Emergency Medical Operation](#)
- [Hospital Service Operation](#)
- [Fire Service Operation](#)
- [Emergency Power Operation](#)
- [Car Recall](#)
- [Capture for Test](#)
- [Test Mode](#)



### Automatic Operation

Automatic operation is the normal, default elevator operating mode. In this mode, cars are accepting hall calls and servicing car calls as determined by Basic Features Menu and other operating menu selections. [Please refer to “Basic Feature Menu Options” on page 5-17.](#)

#### Mode Entry

- Machine Room Inspection Mode Switch: Normal
- Test Switch: Normal
- Car Door Bypass: Off
- Hoistway Door Bypass: Off

## Inspection Operation

In inspection, a car operates at the set inspection speed using up and down buttons or momentary switches. The car will stop as soon as the buttons are released. Inspection operation may be controlled from three locations. For safety purposes, locations have a priority:

- **Top of car:** When the cartop inspection switch input (INCT on the HC-CTL board) is active, operation from the controller or from the car panel is disabled.
- **In-Car:** In car inspection may be from built-in COP switches or from the optional hand-held user interface. When the in-car inspection input (INCP on the HC-CTL board) is active, operation from the controller inspection station is disabled.
- **Machine Room Inspection:** Inspection operation using the switches in the elevator controller. Available only when cartop and/or in-car inspection is not active.

### Cartop Inspection

In this mode, the car is operated by pushing the cartop UP or DOWN and ENABLE buttons simultaneously. These buttons are generally provided through a third-party inspection station wired to inspection operation inputs in the elevator controller. There will also be a key switch that enables/disables inspection operation. In cartop inspection, doors will open (or close) if both UP and DOWN buttons are pressed for more than two seconds while the car is in a door zone.

#### Mode Entry

- Bring the car to the access floor
- Enable hoistway access operation using the in-car switch
- Move the car down until the access limit is opened
  - Top access must prevent the car from moving down beyond the point where the cross-head is even with the hoistway entrance sill.
- Set the cartop switch to Inspection before stepping onto the cartop.
- Use ENABLE and UP or DOWN buttons to run the car from the cartop.

### In Car Inspection

In this mode, the car is typically operated using a locked sub-panel in the COP that provides the inspection key switch and direction buttons. Car doors will open (or close) if both UP and DOWN buttons are pressed for more than two seconds while the car is in a door zone.

#### Mode Entry

- Bring the car to the desired floor.
- Place the car on in-car inspection.
- Press and hold both UP and DOWN buttons simultaneously to close the elevator doors.
- Use UP or DOWN buttons to run the car.



### Machine Room Inspection

In this mode, the car is operated using switches on the HC-CTL (Control) board in the controller.

#### Mode Entry

- Place the car on Machine Room Inspection (Mode Switch to INSP).
- Ensure that car and hoistway doors are closed and locked.
- Run the car using the ENABLE and UP or DOWN Directional switch positions.

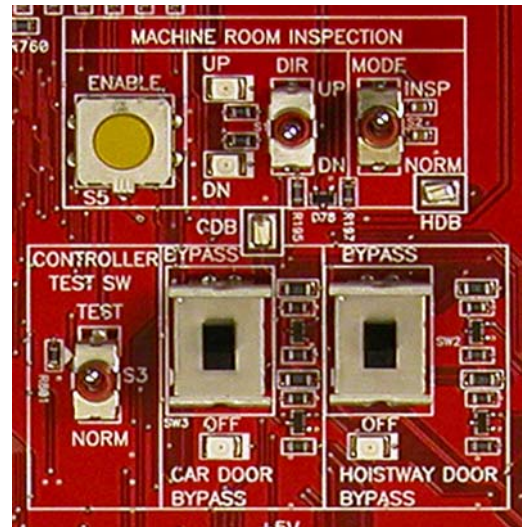

### Hoistway Access Inspection

In the inspection hierarchy, hoistway access operation priority is the same as machine room inspection (in descending order: cartop, in-car, machine room/hoistway access). Hoistway access operation allows workers to access the top and bottom of the car from designated floors. In this mode, the car is brought to an access floor where a special key switch has been installed that allows a worker to move the car up or down the hoistway.

1

#### Mode Entry

- Bring the car to the access floor
- Place the car on Machine Room Inspection
- Place the appropriate Car and Hoistway door bypass switches in the Bypass position
- Enable hoistway access operation using the in-car switch
- Move the car up (bottom access) or down (top access) until the access limit is opened
  - Top access must prevent the car from moving down beyond the point where the cross-head is even with the hoistway entrance sill.
  - Bottom access must prevent the car from moving up beyond the point where the bottom of the toe guard is even with the hoistway entrance header.

## Attendant Service Operation

Attendant operation allows an operator riding in the car to run the car, choosing run direction, and which hall calls to answer. In this mode:

- Doors open automatically when the car is stopped in a door zone.
- The attendant closes the door by pressing and holding the door close button, a car call button, or either car direction (UP/DOWN) button (UPI/DNI input: [Please refer to “Spare Inputs Menu Options” on page 5-29.](#))
- The attendant chooses the direction using run up (UNI) or down (DNI) buttons.
- The car will stop at the next car or hall call in the direction of travel. Holding the bypass button (NSI input) in will cause hall calls to be bypassed until the button is released.
- The elevator will level into the destination floor automatically, then open its doors.
- In-car position indicators will light for floors at which there are active hall calls so that they are visible to the attendant. The car will answer the calls unless the attendant is holding the bypass button (NSI).
- During Attendant operation, load weigher inputs are ignored.

### Mode Entry

- Call the car to a floor.
- Enter the car and activate the Attendant mode key switch (enables the ATS, Attendant Service, controller input).

## Independent Service Operation

In this mode:

- Doors open automatically when the car is stopped in a door zone
- The operator presses and holds the door close button to close doors
- The operator chooses direction and initiates the run by placing car calls (first placed determines direction of run).
- The elevator will level into destination floors automatically and open its doors.
- Hall arrival lanterns or jamb mounted arrival lanterns are inoperative.

### Mode Entry

- Call the car to a floor.
- Enter the car and activate the Independent mode key switch (IND input HC-CTL board).

### Sabbath Operation

Sabbath operation is a special mode that sets the car to consecutively service specified landings (and openings if the car has front and rear doors) during up and down travel with no hall or car call buttons being pressed. The car will begin from the bottom of the hoistway, travelling up and stopping at each designated stop and opening its doors to allow exit or entry. When the doors close, the car will travel to the next designated stop up the hoistway and repeat door operation. This will continue until the car reaches the top designated stop, at which point it will travel down the hoistway operating in the same manner.

- **Initiate:** Sabbath operation is initiated when the spare input SAB is activated.
- **Operation:** In accordance with the description above and servicing stops set through the Sabbath Operation parameter in the Extra Features menu. [Please refer to “Extra Features Menu Options” on page 5-48.](#)

### Emergency Medical Operation

This mode complies to Massachusetts code. It allows a car to be recalled to a floor where it can be boarded by medical personnel and placed in restricted service, using an in-car switch, to respond to a medical emergency.

- **Recall:** Initiated using a key switch (EMSH input) at the floor assigned by the Massachusetts EMS Service/EMS Service Floor parameter in the Extra Features menu (single switch, single floor).
  - The car will immediately cancel all registered calls, return to the designated floor, and open its doors.
- **In-Car Medical:** Medical personnel board the car and place it in hospital service using the in-car switch (EMSC input).
  - If the hall switch has been shut off, the car will wait sixty seconds then return to normal service if the in-car switch has not been activated.
  - If the hall switch remains on, the car will wait without restriction until the in-car switch is activated.

## Hospital Service Operation

Hospital service allows a car to be recalled to any of one or more assigned floors using a call button at the floor. Once at the floor, the car may be boarded by medical personnel and placed in restricted service, using an in-car switch, to respond to a medical emergency.

- Recall: Floors and openings (if the car has front and rear doors) are designated as hospital service through Hospital Emerg Operation parameters in the Extra Features Menu. [Please refer to “Extra Features Menu Options” on page 5-48.](#) When a designated call button is activated, the car will recall to the floor.
  - The car will immediately cancel all registered calls, move to the call floor, and open its doors.
  - A Timer Menu function, Hospital Emergency Timer, allows a timer to be set for a range of up to 10 minutes. After a car recalls to the designated floor, it will remain there until the timer expires, after which it will return itself to automatic passenger service if the in-car, hospital service switch has not been activated.
- Operation: Once the in-car switch (HOSP input assigned through the Spare Inputs Menu) is activated, the car is in restricted service and will accept only calls assigned through the car operating panel.
- When the in-car switch is deactivated, the car returns to normal service.

## Fire Service Operation

There are many different fire codes that restrict or change elevator operation under fire conditions. [Please refer to “Fire Service Menu Options ” on page 5-20.](#) In general, fire service proceeds in two stages; Phase I Emergency Recall and Phase II Emergency In-Car Operation. When a fire sensor or switch is activated:

- The elevator will recall to the designated main or alternate recall floor. (Main if fire detected on any floor other than the main floor; Alternate if fire detected on the main recall floor. Or, as directed by a manually activated Fire switch.)
- The elevator will open its doors to allow any passengers to exit, then remain at the recall floor until the in-car firefighter switch is activated. Once the in-car switch is activated the car will run on Fire Phase II operation as allowed by the selected fire code.

## Emergency Power Operation

Emergency or standby power operation requires a backup power source. For large buildings, this is typically a diesel or gasoline powered generator. When this is not practical, backup power for a limited, rescue operation may be provided by a battery-powered system like the Reynolds & Reynolds Powervator EPS.

### Generator Backup

When power is lost, the elevator will come to a full stop. When emergency/backup power comes on line, the elevator will be moved to a designated recall floor and the doors will open to allow passengers to exit. The elevator will remain at the recall floor unless it is designated to run under generator power. [Please refer to “Extra Features Menu Options” on page 5-48.](#)

### EPS Backup

When power is lost, the elevator will come to a full stop. When battery power becomes available, the EXMLT input is activated and the elevator will be moved to the bottom floor. At the floor, the doors will cycle, allowing passengers to exit, and then close. The car will remain out of service until commercial power is again available.

## Car Recall

Inputs may be provided to allow the car to be recalled to a specified floor.

- CTF: Car To Floor - This is a “spare” input that may be assigned to the HC-CTL board or to a Universal I/O board as configured for the job. The floor to which the car is returned is set by the Car to Floor Return Floor parameter in the Extra Features menu. [Please refer to “Extra Features Menu Options” on page 5-48.](#)
  - When activated, causes the car to stop responding to hall calls. Existing car calls will be serviced. New car calls will not be registered.
  - When existing calls have been serviced, the car will move to the return floor, open then close its doors, and remove itself from service.
- CTL: Car to Lobby - This is a “spare” input that may be assigned to the HC-CTL board or to a Universal I/O board as configured for the job. The floor to which the car is returned is set using the Lobby Floor parameter in the Basic Features menu. [Please refer to “Basic Feature Menu Options” on page 5-17.](#)
  - When activated, causes the car to stop responding to hall calls. Existing car calls will be serviced. New car calls will not be registered.
  - When existing calls have been serviced, the car will move to the return floor, open then close its doors, and remove itself from service.

## Capture for Test

CTST: Capture for Test - This is a “spare” input that may be assigned to the HC-CTL board or to a Universal I/O board as configured for the job.

- When this input is activated, the car will stop responding to hall calls and disable its gongs but continue to service car calls.
- The intent of the input is to allow maintenance personnel to capture the car while causing as little disruption to service as possible.

## Test Mode

Test mode allows the car to be run without operating the doors. When Test mode is active, door open circuitry is deactivated.

- Enter Test mode by placing the TEST/NORMAL switch on the HC-CTL board in the TEST position. (The car will not enter Test mode if Inspection is active.)
- When Test mode is active, the controller LCD will display TEST MODE.

## Monitoring and Control Options

Motion 2000 is Ethernet ready, allowing it to use iMonitor and iReport applications for local and/or distance monitoring and control (iMonitor) or report generation, archival, and automated alert (iReport). Motion 2000 can also be linked to Building Management System software through MCE BMS-Link, providing system visibility and limited control.

### iMonitor

iMonitor is an elevator monitoring application that allows local or remote viewing and control of MCE elevator groups using a personal computer running the Windows XP operating system. Because Motion 2000 controls are Ethernet capable, you can connect to them through a local area network or remotely through internet/modem technology.

iMonitor provides a graphical representation of elevator groups, allowing their activity and status to be quickly and easily viewed. The user defines any number of "Connection Sets." Each Connection Set consists of up to fifty connections to elevator group dispatchers selected by the user.

When working in iMonitor, the user simply clicks on a Connection Set which automatically establishes communication with all groups in the set and displays their associated hoistways and cars on the computer screen. Practical viewing limits are established by the speed of the connections and the size of the monitor viewing area.

When connected through iMonitor, the user may register car and general, auxiliary, or special hall calls as desired, control many group security functions, and enable or disable certain elevator operating modes.



### iReport

iReport is a system logging and report generating tool that allows local or remote analysis of MCE elevator groups from a personal computer running the Windows XP operating system and iReport client software. Because Motion 2000 controls are Ethernet capable, you can use iReport to connect to them through a local area network or remotely through internet/modem technology.

iReport consists of the iReport server and iReport clients. Motion 2000 group dispatchers may be connected to iReport directly through a local area network or they may be connected remotely through a DSL or other high-speed connection and the internet. The group dispatcher provides iReport with hall call and car operating mode information. The individual car controllers provide iReport with event and fault notifications.

## BMS-Link

BMS-LINK uses the Niagara Framework developed by Tridium. The framework is a field-proven Java implementation that provides a reliable structure through which intelligent equipment may connect in a machine-to-machine environment. Motion Control Engineering and Gemini Integration Systems developed the software structure that integrates MCE iControl, Motion 2000, and Motion 4000 elevator controls and Motion 3000 escalator controls into this robust environment.

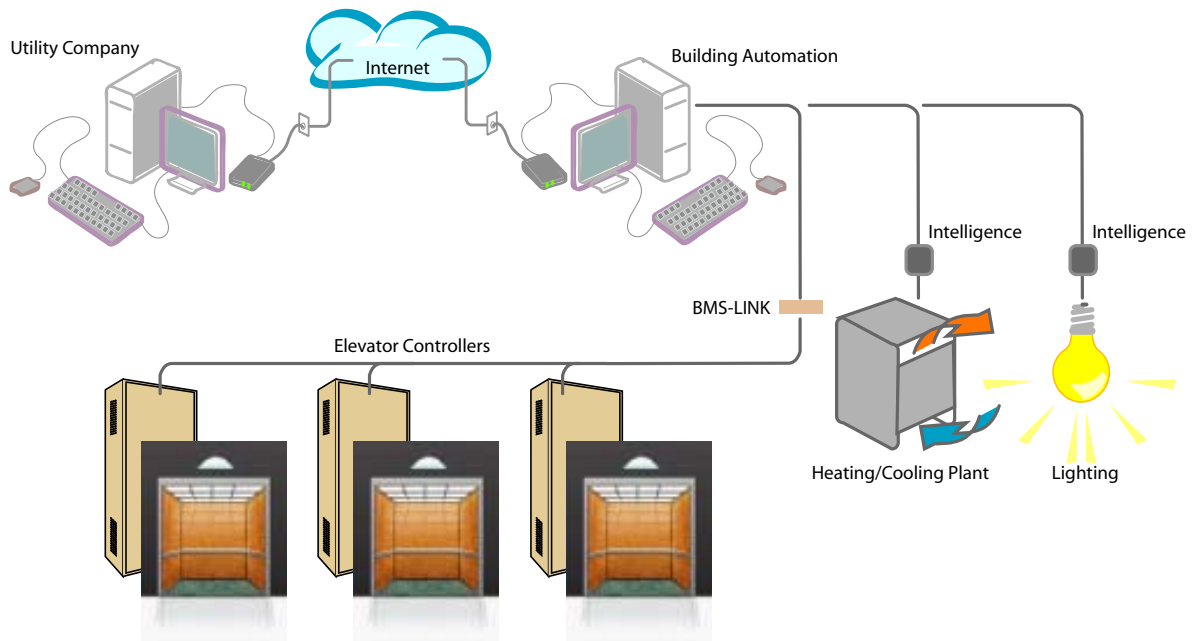

## Motion Portable Adjustment Control (mPAC)

The hand-held user interface provides the same user functionality as does the HC-MPU board inside the controller. The mPAC can be plugged in to a CAN connection in the controller, on the cartop, or in the car (if one is wired). In addition, the mPAC can be used to transfer new firmware to Motion 2000 and Motion 4000 controllers.





## mView

The mView application runs on a standard PC connected to the controller through an Ethernet hub or switch. mView provides local monitoring, status and event log viewing, diagnostics, and call registration for one or more Motion controllers.

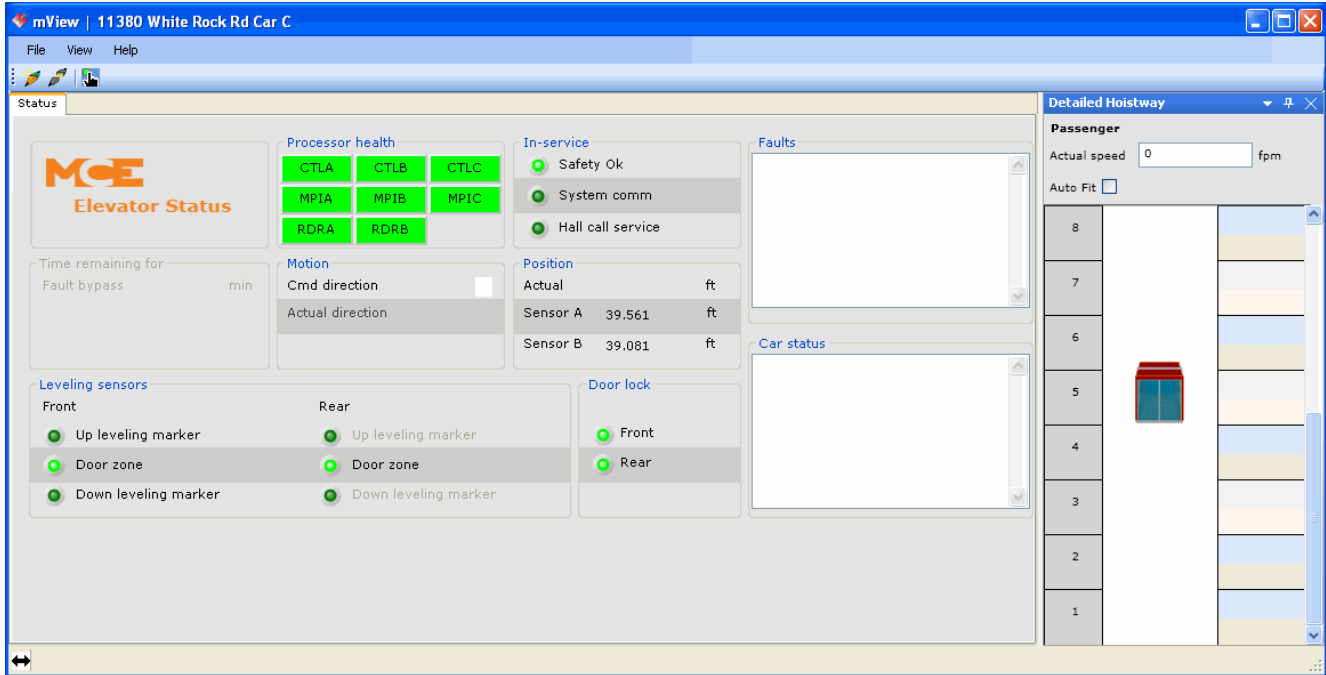

1





## Quick Topics

- In this Section
- Safety Precautions
- Machine Room Preparation
- Piping and Wiring
- Recommended Tools
- Wiring Prints
- Controller Installation
- General Wiring Guidelines



## Installation

2

### In this Section

This section contains important recommendations and instructions for installing the Motion 2000 Hydraulic controller. If you are viewing this on a computer, click the page number to jump to the appropriate section.

- **Safety Precautions:** Precautions for personal and equipment safety (see [page 2-2](#)).
- **Machine Room Preparation:** Site selection and environmental considerations (see [page 2-3](#)).
- **Piping and Wiring:** Suggestions for avoiding electrical noise and EMI/RFI (see [page 2-4](#)).
- **Recommended Tools:** Tools and test equipment recommended for installation (see [page 2-5](#)).
- **Wiring Prints:** Job print and nomenclature conventions (see [page 2-5](#)).
- **Controller Installation:** Suggestions for proper controller wiring (see [page 2-7](#)).
- **General Wiring Guidelines:** Suggestions for proper grounding and wiring (see [page 2-8](#)).

## Safety Precautions

Certain fundamental warnings must be kept in mind at all times to help avoid severe personal injury or equipment damage.

### Personal Safety

- Motion 2000 Controllers should only be installed by qualified, licensed, trained elevator personnel familiar with the operation of microprocessor-based elevator controls.
- Verify that all safety devices (limits, hoistway locks, car gate, etc.) are fully functional before attempting to run the elevator. Never operate Motion 2000 controls with any safety device inoperative.
- The user is responsible for complying with the current National Electrical Code with respect to the overall installation of equipment and for proper sizing of electrical conductors connected to the controls.
- The user is responsible for understanding and applying all current local, state, provincial, and federal codes that govern practices such as controller placement, applicability, wiring protection, disconnections, over current protection, and grounding procedures.
- Controller equipment is at line voltage when AC power is connected.
- After AC power has been removed, internal capacitors can remain charged for up to 5 minutes. Wait at least 5 minutes after power down before touching any internal components.
- To prevent the risk of shock, all equipment should be securely grounded to earth ground with a minimum of #8 AWG wire as outlined in the National Electrical Code. Failure to obtain an actual earth ground may result in electrical shock to personnel and/or improper operation of the equipment.
- When using test equipment (oscilloscopes, etc.) with a power cord that electrically ties probe common to earth ground, an isolation transformer should be used to isolate the instrument common from earth ground.
- Remain clear of all rotating equipment while working on the controls.

### Equipment Safety

- All equipment should be securely grounded to earth ground with a minimum of #8 AWG wire as outlined in the National Electrical Code. Failure to obtain a true earth ground may result in electrical shock. Improper grounding is the most common cause of electrical component failure and noise-induced problems.
- Replace components only with main line power off. Damage to equipment or unexpected operation of the elevator may occur if this precaution is not observed.
- Substitution of parts or unauthorized modifications should not be attempted before first contacting Motion Control Engineering to ensure all safety features are maintained. MCE will not be held responsible for circuit modifications made in the field unless they are approved in writing by MCE.
- Circuit boards believed to be defective must be sent to MCE for repair and testing. Field repair may leave the board with undetected problems.
- Care should be taken when using test leads and jumpers to avoid shorting high voltage or ground to low voltage microprocessor circuits.

## Installation Considerations

1. Dust, carbon, or metallic particles should not be allowed to accumulate on any part of the control.
2. Avoid vibration and shock.
3. Avoid rapid temperature change, high humidities, high ambient temperatures.
4. Avoid caustic fumes.
5. Prevent electromagnetic interference. This may be caused by radio transmitters, high voltage inductive spikes from unsuppressed relay coils, improper grounding, and improper wiring practices. The following should be noted:
  - The outer door will protect against interference only if closed. When the door is open, do not run high wattage radios next to the microprocessor.
  - Noise from door operator reactors can cause a problem if mounted on the controller.
  - Standard arc suppressors (resistor/capacitor networks) are used on AC relays. Diode/resistor combinations work well for DC relays. Consult Motion Control Engineering for proper component sizing.

## Machine Room Preparation

### When choosing equipment location, consider:

- Adequate working space for comfort and efficiency and a good working space such as a workbench or table.
- Logical arrangement, taking into consideration other equipment in the machine room and electrical power.
- Do not install equipment in a hazardous location.
- A telephone in the machine room facilitates remote diagnostic and adjustment assistance.
- If any areas in the machine room are subject to vibration, they should be avoided or reinforced to prevent equipment damage.
- Provide adequate lighting to work with control cabinets and machines.
- Wiring is reduced if the drive isolation transformer (if used) is located near the controller.

### Environmental conditions are important:

- Ambient temperature should remain within 32° to 104° Fahrenheit (0° to 40° Celsius). Temperatures outside these guidelines may be tolerated, but will shorten equipment life. Adequate ventilation is required. Air conditioning may be necessary.
- The air in the machine room should be free of excessive dust, corrosive elements, and excessive moisture. A NEMA 4 or NEMA 12 enclosure can help meet these requirements if machine room conditions are inadequate. If the machine room has open or unglazed windows or other direct outside openings, place equipment cabinets far enough from them so that severe weather does not damage the equipment.
- Very high levels of radio frequency (RF) radiation from nearby sources should be avoided. RFI may interfere with controller components, degrading elevator performance. Using hand-held communication devices close to the controller may also cause interference. Interference from permanently installed radio transmitting antennas is not common.
- Power line fluctuation should not be greater than  $\pm 10\%$ .

## Piping and Wiring

Proper routing of signal and power wires for the car and dispatcher is essential to trouble free installation of microprocessor based equipment. Low voltage and high voltage wiring cannot be run in the same conduit, duct, or tray.

### How Electrical Noise Occurs

Electrical noise occurs in most cases when two wires run along side one another with one of them a high power conductor and the other a low signal level conductor. As current flows through the high power wire, magnetic lines of flux (voltage) expand outwards around the outside of the wire and voltage from the magnetic lines of flux is induced in the low level conductor.

The low level conductor, in the case of Motion 2000, may be a 24-volt input that really only needs to see 12 volts to turn on. If the voltage induced from the high power conductor is large enough to induce a 12-volt spike, the input can falsely turn on.

### How to Avoid Electrical Noise Problems

The easiest way to avoid noise problems is to properly route high and low level signal wiring. Keep low level wiring in separate conduit from high power wiring. If high and low power wiring must be run in the same duct, separate them by a minimum of three to four inches. If one must cross the other, it should be at a ninety degree angle.

A second way to protect against electrical noise problems is to run low level wiring in shielded cable. The shield provides a conductor external to the actual signal wiring to collect any induced voltage from surrounding high power wiring. The shield or “drain”, as it is often referred to, must be connected to ground at one end. The shield or “drain” should never be connected to ground at both ends.

### Possible EMI/RFI Interference

The main source of EMI/RFI problems is semiconductor devices that switch at high frequencies (such as variable frequency drives). The following wiring practices should be followed when piping and wiring high voltage lines to avoid EMI problems:

1. Run all motor leads in a separate conduit. All motor lead runs should be as short as possible. Control cabinet entry should be as close to the final termination point as possible.
2. Run main line supply leads in a separate conduit.
3. Run all primary isolation transformer wiring in separate conduit from the main line to the transformer.
4. Run all secondary isolation transformer wiring in a separate conduit from the transformer to the drive cabinet.
5. A single-point ground should be established inside the control cabinet and a #8 AWG ground wire run directly from each of the following devices to this single point:
  - Earth Ground from running water supply, Motion 2000-electric supplied ground, or a ground supplied via an earthing rod to the single ground stud.
  - Continuous wire from the main line disconnect to the single ground stud.
  - Continuous wire from the motor frame to the single ground stud.
  - Continuous wire from the isolation transformer frame to the single ground stud.
  - Continuous wire from the line filter frame to the single-point ground stud.

- Jumper the “N” stud on the line filter to the line filter frame.
- Continuous wire from the load reactor frame to the single-point ground stud.
- Continuous wire from the drive frame ground stud to the single-point ground stud.

## Recommended Tools and Test Equipment

For proper installation, use the following tools and test equipment:

- A digital multimeter, Fluke series 75, 76, 77 or equivalent
- A hand-held tachometer
- A clamp-on AC ammeter
- Hand-held radios
- A telephone
- Test weights
- Pressure gauge
- Soldering tools, a flashlight and an MCE screwdriver (provided with controller).

## Wiring Prints

Become familiar with the following information as well as the wiring prints provided with this control system.

2

## Drawing Number Format

Each print has a drawing number indicated in the title block. The drawing number is comprised of the job number, car number and page number (see example). In this manual the drawings will often be referred to by the last digit of the drawing number (page number). The following is the drawing number format currently in use.

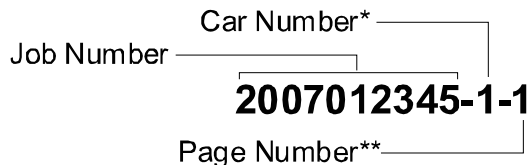

\* Car Number “G” = Group Controller

\*\* Page Number “S” = Starter page

\*\* an “X” after the page number = auxiliary page

Note

**Drawing Name:** Some drawings have a drawing name directly above the title block or at the top of the drawing. The drawing name may be used to refer to a particular drawing.



## Nomenclature

A listing of PC boards and their designator numbers plus other schematic symbols used in the wiring prints can be found at the beginning of the Job Prints and in the Component Nomenclature table below.

- Become familiar with the “Elevator Car Wiring Print” drawing number -1.
- Become familiar with the “Elevator Hoistway Wiring Print” drawing number -2.
- Become familiar with page -2DI of the job prints for duplex interconnect wiring if this application is duplexed.
- Review any additional wiring diagrams and details.
- The remainder of the job prints are detailed drawings of the Motion 2000 Hydraulic Control system.
- A specific part of a schematic may be referenced by the Area Number, which is found at the left-hand margin of the schematic.

The following table lists MCE part numbers and provides a brief description for each. Your installation may not use all boards listed.

**Table 2.1 Component Nomenclature**

Symbol	Component	Description
10	HC-DB-MOD	Front G. A. L. MOD Door Interface Board
11	HC-DB-MOD-R	Rear G. A. L. MOD Door Interface Board
32	HC-OA	Output Adaptor Board
44	HC-GB	Gong Board
45	HC-GB	Additional Gong Board
70	HC-CTL	Controller Board for Motion 2000/4000
71	HC-RDR	Rear Door Board for Motion 2000/4000
72	HC-DVR	Hydraulic Driver board for Motion 2000
73	HC-UIO	Universal I/O Board for Motion 2000/4000
75	HC-CHP	CAN HUB and Power Board for Motion 2000/4000
76	HC-MPU	Main Processor Board for Motion 2000/4000
	MC-CPI	Car Panel Interface Board
	MC-LSI	Landing System Interface Board
	SC-3HN	Serial Hall Call Node Board



## Controller Installation

Mount the controller securely to the machine room wall or other appropriate location and knock out holes to install a raceway or conduit to permit the routing of wires into the cabinet. Note that the standard MCE control cabinet does not require rear access.



### Caution

Do not allow any metal chips or drill shavings to fall into the electronics.

## Controller Wiring Guidelines

Detailed instructions for connecting the Motion 2000 controller and accompanying components are contained in the drawings package for the job. During the job survey, site-specific information collected is used to engineer the drawings package. Contact Motion Control Engineering immediately if you have questions about the drawings or need additional assistance.



### Note

Pay very close attention to the hierarchy of the inspection inputs. In order to maintain safe operation of the lift while on access, car top or in-car inspection, the inspection circuits must be wired as shown in the prints.

2



### Caution

PC boards can be easily damaged by Electrostatic Discharge (ESD). Use a properly grounded wrist strap when touching the PC boards. **Do not touch PC Boards unless you are properly grounded.**

1. Bring wires in from a location that allows the use of the wiring duct inside the controller to route the wires. The terminals are found conveniently near wiring ducts.
2. When connecting wires to the controller, connect the wires according to the hoistway and car wiring diagrams.
3. If the car is part of a duplex or group system, there are a number of details relating to the wiring of the interconnects between the individual cars. They are as follows:
  - A separate conduit or wiring trough must be provided for the external CAN connections between the computers in each controller cabinet.
  - The wiring details for the communication link are fully detailed in the job prints.
  - Make sure to ground all of the cabinets according to the section titled *Ground Wiring*. Please refer to “Ground Wiring” on page 2-9.

## General Wiring Guidelines

Basic wiring practices and grounding requirements are discussed in this section.

### Proper Grounding Procedures

A proper ground is essential to trouble free operation. Ground is defined as a direct connection to EARTH GROUND. This type of ground is not always available from the electrical supply panel.

The electrical conduit is not a sufficient ground for the system. Electrical ground should be obtained and certified from the electrical contractor. If this is not available, keep the following in mind when seeking an adequate connection to EARTH GROUND:

1. Building steel is not always earth ground. In most cases, building beams rest on concrete beam pockets, and the earth connection is inadequate.
2. Sprinkler system water pipe is **not** adequate because the sprinkler system is, in most cases, isolated from a free flowing earth water source.

If either of the two methods above are chosen for ground, and a true electrical ground is later introduced to the system, a difference in potential can occur between the assumed ground and the actual earth ground. This may lead to unsafe operating conditions and the possibility of electrical shock to passengers or personnel.

3. A water pipe is an adequate ground only if the water in the pipe is connected to a continuous city water source.

### Wiring Connections for Properly Grounded Systems

1. An uninterrupted ground wire of at least #8 AWG should be run from each car controller cabinet chassis or back plate to earth ground. The connection at the car controller must be free of paint so the ground connection is made to the bare metal of the enclosure. The car controller should read less than 1-ohm to ground with the power off.
2. Ground straps, or short loops of ground wire, should be run from the controller ground connection to the primary duct connections.
3. An uninterrupted #8 AWG ground wire should be run from the hoist motor frame to the controller ground. The ground connection to the hoist motor must be free of paint.
4. An uninterrupted ground wire of minimum #14 AWG should be run from a termination point on the cab to the controller ground.
5. An uninterrupted ground wire should be run from the cab enclosure to the ground terminal on the cab to protect passengers and personnel from electrical shock.
6. An uninterrupted ground wire should be run from each car operating panel to the ground terminal on the cab to protect passengers and personnel from electrical shock.
7. An uninterrupted ground wire should be run from the dispatch cabinet chassis or back plate to earth ground. The connection at the dispatch cabinet must be free of paint so the ground connection is made to the bare metal of the enclosure.

## Ground Wiring

To obtain proper grounding, quality wiring materials and methods should be used.

All grounding in the elevator system must conform to all applicable codes. Proper grounding is essential for system safety and helps to reduce noise-induced problems. The following are some grounding guidelines:

- The grounding wire to the equipment cabinet should be as large as, or larger than, the primary AC power feeders for the controller and should be as short as possible.
- The grounding between equipment cabinets may be branching or a daisy chain, but the wire must terminate at the last controller and NOT loop back (see Figure 2.1).

Figure 2.1 Ground Wiring to Controller Cabinets

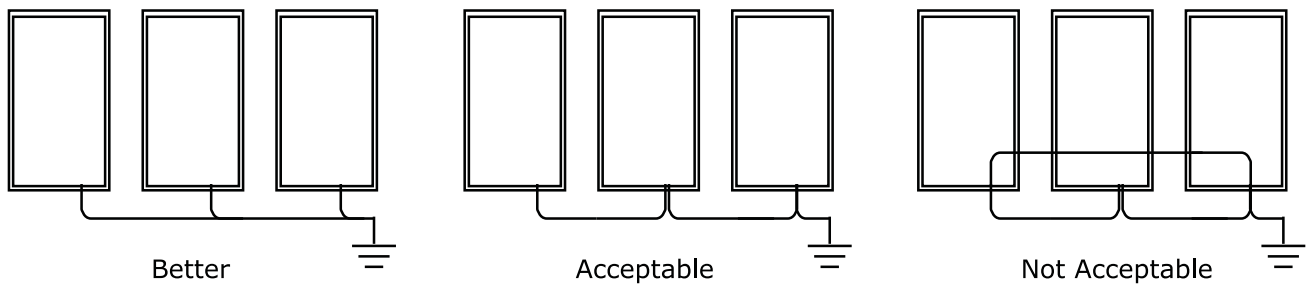

2

- Direct solid grounding must be provided in the machine room to properly ground the controller and the motor. Indirect grounding, such as the building structure or a water pipe, may not provide proper grounding and could act as an antenna radiating RFI noise, thus, disturbing sensitive equipment in the building. Improper grounding may also render an RFI filter ineffective.
- The conduit containing the AC power feeders must not be used for grounding.

## Main AC Power

Main AC power supply wiring size must be determined by the electrical contractor. Proper motor branch circuit protection must be provided according to applicable electrical codes in the form of a fused disconnect or circuit breaker. Each disconnect or breaker must be clearly labeled with the elevator number.

## Pump Motor Wiring

Connect the pump motor for the proper configuration shown on the wiring diagrams. Connect the pump motor leads to the proper terminals on the controller.

### Low Voltage Signal Wiring

Low voltage signal wiring includes all 24-volt inputs. The inputs on the I/O boards can be turned on with as little as 12 Vac. If the signal wires are run along side the 240 Vdc door operator wiring, an induced 12-volt spike is very likely to occur. Keep low level signal wiring at least four inches from high power wiring to avoid false signal firing. If this is not possible, and the low level wiring must cross the high power wiring, the two should cross at a ninety-degree angle.

### Traveling Cable Wiring

When laying out traveling cable wiring, it is always best to have the low voltage signal wiring multiple layers away from any 14-18 AWG power wires and high voltage signal wires.

The number of required wires and twisted pairs is documented in the job prints. The travelers are also identified by the use of yellow terminals in the top of the car junction box. Always allow 10% or more additional wires for spares.

On lower rise cars, it is often beneficial to run the traveling cable directly to the top of the car junction box. This avoids terminating traveler wires at the midway and at the under-car junction box.



## Quick Topics

- In this Section
- Check for Shorts to Ground
- Before Applying Power
- Applying Power
- Operating under Construction
- Verifying Starter Operation
- Install the Landing System
- Hoistway Limit Switches
- Door Position Monitor
- Complete Field Wiring
- Preparing to Run on Test



## Startup - Inspection Operation

3

### In this Section

This section discusses preparing the car to run on Inspection operation. It covers the sequence of applying power to the controller and verifying proper motor rotation. It also covers completing the installation of hoistway equipment, initial adjustment of the system and preparing the car for normal operation and final adjustment.

- **Check for Shorts to Ground:** How to check for shorts to ground (see [page 3-2](#)).
- **Before Applying Power:** Things to do before applying power (see [page 3-2](#)).
- **Applying Power:** Steps to apply power and check for proper pump motor rotation (see [page 3-3](#)).
- **Set Up for Construction Operation:** Minimum requirements to allow the car to run while still under construction (see [page 3-4](#)).
- **Verifying Proper Starter Operation:** How to verify proper starter operation (see [page 3-6](#)).
- **Installing the Landing System:** Instructions for installing the landing system (see [page 3-8](#)).
- **Installing the Hoistway Limit Switches:** How to install the hoistway limit switches (see [page 3-9](#)).
- **Door Position Monitor Switch:** Installing the door position monitor switch, if used. (see [page 3-9](#)).
- **Complete the Installation and Field Wiring:** Finish the installation and wiring and check for shorts (see [page 3-10](#)).
- **Preparing the Car to Run on Test/Normal Mode:** How to prepare the car for running on automatic operation (see [page 3-11](#)).

## Check for Shorts to Ground

Check for shorts to ground before powering up the system. Set the meter for resistance measurement (100 to 200 ohm range). Take all measurements with respect to the 1-bus, which is also referred to as the system common or common elsewhere in this manual.



### Note

A short to ground is defined as having a resistance of less than 20 ohms between the 1-bus (common) and the terminal being checked.

1. Remove fuse F2 from the PCB mounted fuse holder on the HC-CTL Main Control board in the individual car controller cabinet. If the system is a duplex controller, refer to the job prints and remove the fuse that powers terminals 2H (Hall Call Power Bus) and/or 2FS (Fire Service Bus). Check for shorts to ground on the 2H and/or 2FS terminals.
2. Check for shorts to the ground on all screw terminals on the bottom of the HC-CTL Control board. Terminal 1 bus is the only terminal that should be grounded.
3. Check for shorts to ground on all terminals on the HC-UIO Universal I/O board.
4. Check for shorts to ground on the door operator terminals. Consult the job prints to determine which fuses to remove.

## Before Applying Power



### Note

These instructions assume adequate electrical troubleshooting experience. Follow the procedure carefully. If the elevator does not respond correctly, check the circuits according to your ability. Proceed cautiously. Read these instructions fully to become familiar with the procedure before starting the work.

1. Unplug the screw terminal blocks from the HC-UIO Universal I/O boards by moving the blocks toward the right. This is done to avoid damaging the boards through an accidental shorting of the output devices to a power buses (terminals 2, 2S, or 2L) during the initial power up of the system.
2. Verify that all circuits are wired to the controller properly.
3. On the HC-CTL Control board, verify that the MACHINE ROOM INSPECTION - MODE switch is in the INSP position.
4. On the HC-CTL Control board, verify that the Hoistway Door and Car Door Bypass switches are in the OFF position.
5. Verify that the Main Line Power Supply voltage matches the controller's designed voltage. Refer to the job prints provided with the controller and the silver label on the solid state starter (if used).

## Applying Power

### Initial Adjustments and Power Phasing

When performing the following steps please exercise extreme caution to prevent personal injury or damage to components and equipment. Have someone stand by the main power disconnect switch during the following phases of the start up procedure for added safety:

- First time power is applied to the controller
  - First time an attempt is made to move the car
1. Check the line side of the Main Power Disconnect switch to verify that all three legs are at the correct voltage.
  2. Reinstall fuse F2 on the HC-CTL Control board to enable the primary controller relay voltage.

### Verify Proper Pump Motor Rotation

1. Verify that the pump motor wiring has been installed per the job prints.
2. Turn ON power to the controller by closing the Main Power Disconnect switch.
3. Check the pump motor rotation using the method that is appropriate for the type of starter installed on the controller:
  - **Solid State Starter:** Take a jumper from 2 bus and briefly apply it to the “motor run” screw terminal on the solid state starter and observe the motor rotation.
  - **Y-Delta contactor:** Activate the Y contactor and observe motor rotation.
  - **Across the line (ATL) contactor:** Activate the A contactor and observe motor rotation.
4. Faults may occur while performing this operation. To clear latching faults, press the FAULT RESET button on the HC-CTL Control board.
5. If the motor rotation is reversed, switch any two of the three leads at the Main Disconnect switch.
6. If an RP (Reverse Phase) sensor is provided and the sensor contact does not close when power is applied to the controller (indicated by a light on the sensor that comes on when phase rotation is correct), then 2 of the 3 AC wires that connected to the RP sensor may need to be switched.
7. To provide an immediate stop once direction is released, set the SOFT STOP TIMER option on the ASME A17.1-2000 FEATURES menu to NONE (see [“SOFT-STOP TIMER” on page 5-53](#)).

3

#### Note

The HIGH SPEED INSPECTION option determines if the car will run at high or low speed on Cartop Inspection, Hoistway Access, or Machine Room Inspection (see [“HIGH SPEED INSPECTION” on page 5-65](#)). If the car’s contract speed is greater than 150 fpm, the HIGH SPEED INSPECTION option should be set to DISABLED.

## Set Up for Construction Operation

If required, it is possible to run the car during construction to help complete work in the hoistway. In this mode, the car runs at inspection speed. If they are in place, cartop controls may be used or the car may be run from the controller or a temporary run box. (Please refer to “Temporary Run Box Hookup” on page 3-5.)

### Required Connections

Minimal equipment requirements are:

- Pump motor and valves.
- SAFH, SAFC, ESC: Hoistway and car safety devices. Connecting 2 bus to these terminals (as described in Table 3.1) will cause relay SAFS on the HC-CTL board to pick and light the SAFS indicator (provided no safety dropping faults are present).
- GS, DLAB: Door locks. (GSR, DLABR: Rear door logic and door locks.) Connecting 2S bus to these terminals will cause relay SAFL on the HC-CTL board to pick and light the SAFL indicator. The DLK indicator on the HC-MPU board will turn ON (provided that no safety dropping faults are present).
- TO2: Thermal overload protection. Connecting TO1 to TO2, as specified on the job prints, will clear the OLM INPUT IS LOW fault (Overload monitor). When this fault is present the car can only move down.
- DNTD, UNTD: Up and down terminal limit switches. Connecting 2L bus to these terminals clears the faults caused by the final limit terminals being open.
- USL1, USL2, DSL1, DSL2: Slow down limits. Connecting 2L bus to these terminals clears the faults caused by having both sets of slow down terminals open.
- Custom Connections: Custom spare input connections that are active low and affect car motion, such as the Pressure Switch and Low Oil Switch, must be installed.

### Temporary Jumpers

Temporary jumpers, as necessary, may be connected if needed to run the car on construction / inspection operation. For Temporary Run Box connections see [page 3-5](#).

**Table 3.1 Construction Mode Jumper Requirements**

From	To
2 bus	SAFH on HC-CTL board (Safety String, Hoistway)
SAFH on HC-CTL	SAFC on HC-CTL board (Safety String, Car)
SAFC on HC-CTL	ESC on HC-CTL board (In-car Emergency Switch)
2S bus (120VAC)	GS on HC-CTL board (Gate Switch, car door locks)
2S bus (120VAC)	GSR on HC-RDR board (Rear Gate Switch, car door locks)
2S bus (120VAC)	DLAB on HC-CTL board (Door Lock Access Bottom, hall doors)
2S bus (120VAC)	DLABR on HC-RDR board (Rear Door Lock Access Bottom, hall doors)
2S bus (120VAC)	DPM on HC-CTL board or HC-UIO board (Door Position Monitor)
2S bus (120VAC)	DPMR on HC-RDR board or HC-UIO board (Door Position Monitor Rear)
TO1 on HC-DVR	TO2 on HC-DVR board or install thermal overload as specified on job prints
2L bus (120VAC)	DNTD and UNTD on HC-DVR board (Normal Terminal inputs)
2L bus (120VAC)	USL1, USL2, DSL1, DSL2 (Slow down limits) to clear faults. Must be installed to run the high speed valves while on Construction Mode. However, if the car's contract speed is greater than 150fpm, set HIGH SPEED INSPECTION option to DISABLED (see <a href="#">page 5-65</a> ).
2FS bus (120VAC)	FRS, FRSA, and FRSM on HC-CTL board (Fire Service inputs) only required to clear faults. Car will run on Inspection without the jumpers.



### Resolving Faults

If the car does not respond to a run command, check the HC-MPU board for error/fault codes. Please refer to “Status and Error Messages” on page 6-3. Error codes are displayed individually in the order of detection. It is possible that, after you correct a current error condition, another will be displayed. All errors must be resolved before the car will operate properly.

### Temporary Run Box Hookup

The following illustration shows a temporary run box hookup. Disconnect controller power before attempting to wire the run box. The temporary run box must have an enable button, an up button, a down button, and a stop (Insp/Norm) switch (see Figure 3.1).



**Caution**

For safety, keep the controller Machine Room Inspection switch in the INSP position while the Temporary Run Box is in use.

**Caution 2**

If a jumper was installed between HC-CTL board terminals SAFH and SAFC as described in Table 3.1 *Construction Mode Jumper Requirements*, that jumper must be removed when a temporary run box is connected (see Figure 3.1).

Figure 3.1 Temporary Run Box

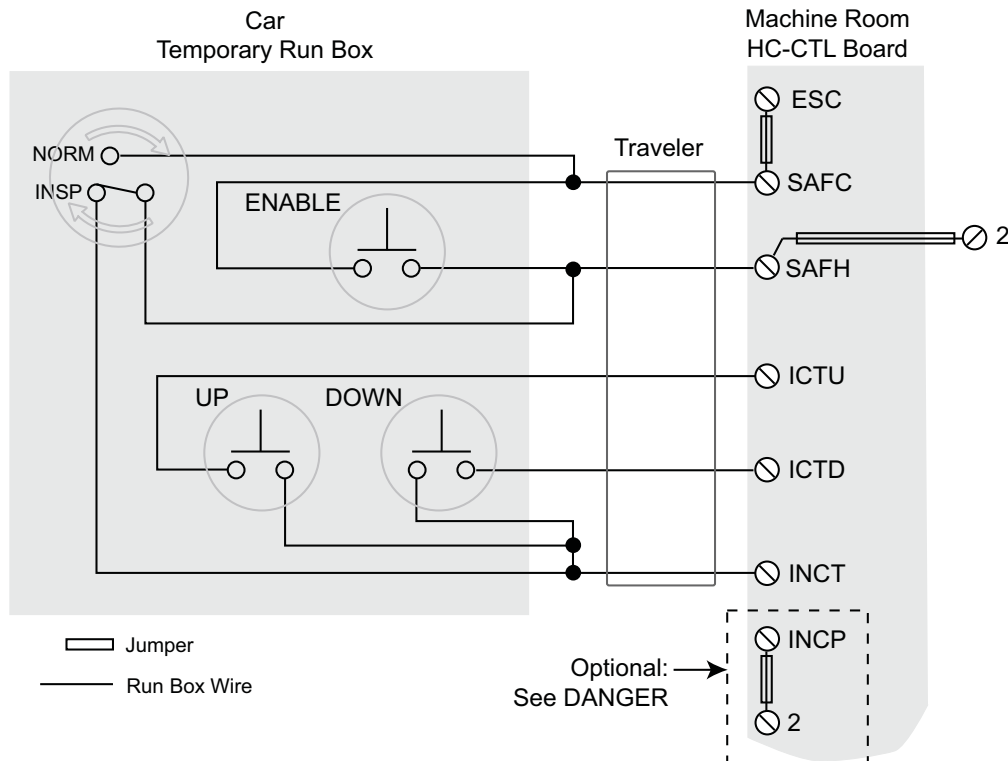

**Danger**

Wire the Temporary Run Box as shown above for safe operation. The jumper from 2 bus to INCP prevents the car from operating in Normal mode in the event of loss of the connection to INCT (Note that connecting 2 bus to INCP will prevent operation on Machine Room Inspection). It is imperative that any temporary jumper installed in the controller be removed as soon as the equipment wiring it is simulating is in place. Temporary jumpers or wires may not be stored in the control room or space.

## Verifying Proper Starter Operation

1. Verify that any fuses removed during the ground check have been reinstalled. If not, turn power OFF at the Main Power Disconnect switch, reinstall the fuses and then turn power back ON. Verify that the Machine Room Inspection Mode switch on HC-CTL board is in the INSP position.
2. When power is turned ON, the LCD display on the HC-MPU Main Processor board will display the message MOTION CONTROL ENGINEERING, INC, then change to MOTION CONTROL M-2000, and then change to MACHINE ROOM INSPECTION or, if an error condition is present, will scroll the error message instead. If there is an error condition, it must be addressed or bypassed with a temporary jumper (see [“Troubleshooting Tools” on page 6-2](#)).
3. LEDs SAF ON, DLK, and INSP should be ON and relays SAFL and SAFS should pick as indicated by the SAFL and SAFS LEDs. Use the MACHINE ROOM INSPECTION switches on the HC-CTL Control board to move the car up or down. Press and hold the ENABLE button and then hold the DIR switch in the UP or DN position.
4. Follow the appropriate instruction below for the type of starter (solid state, Y-Delta or ATL) installed on the controller.

**Solid State Starter** The Solid State starter will control the starting current to the motor (see the Solid State starter manual). Adjust the UP TO SPEED TIMER option, see [“UP TO SPEED TIMER” on page 5-53](#)) to provide a sufficient delay for the pump motor to get up to speed. Once the pump is at speed, the valves will be activated. If the motor does not spin when a demand up is present:

- Verify that there are no faults displayed on the HC-MPU board LCD display or the solid state starter display.
- Verify that relays SAFS and SAFL are picked.
  - If neither relay is picked, check fuse F2 and then verify that the voltage measured between terminals 1 (1Bus) and 2 (2 Bus) is 120 VAC.
  - If relays SAFS and SAFL pick but the motor does not spin, check the thermal overload contact.
  - If relay SAFS does not pick, briefly place a jumper between 2 Bus and the SAFC screw terminal on the HC-CTL board (bypasses the safety string). If relay SAFS picks with the jumper, troubleshoot the safety string.
  - If relay SAFL does not pick, briefly place a jumper between 2 Bus and the DLAB screw terminal on the HC-CTL board (DLABR on the HC-RDR board). Make sure that relay GS on the HC-CTL board is also picked (GSR on the HC-RDR board). If relay SAFL picks with the jumper, troubleshoot the door lock string.

**Y-DELTA Starter** The Y contactor picks first. Then, after a programmable delay, (the delay is dependent upon the “Y/D TRANSFER TIMER”, (see “Y-D OPEN TRANSN. TIMER” on page 5-53)) the Y contactor should drop and the DEL contactor should pick.

1. If the Y and DEL contactors do not pick when a demand up is present:
  - Verify that there are no faults displayed on the HC-MPU board LCD display.
  - Verify that relays SAFS and SAFL are picked.
    - If neither relay is picked, check fuse F2 and then verify that the voltage measured between terminals 1 (1Bus) and 2 (2 Bus) is 120 VAC.
    - If relays SAFS and SAFL pick but the Y contactor does not, check the starter overload and thermal overload contacts.
    - If relay SAFS does not pick, briefly place a jumper between 2 Bus and the SAFC screw terminal on the HC-CTL board (bypasses the safety string). If relay SAFS picks with the jumper, troubleshoot the safety string.
    - If relay SAFL does not pick, briefly place a jumper between 2 Bus and the DLAB screw terminal on the HC-CTL board (DLABR on the HC-RDR board). Make sure that relay GS on the HC-CTL board is also picked (GSR on the HC-RDR board). If relay SAFL picks with the jumper, troubleshoot the door lock string.
2. Adjust the Y-D TRANSFER TIMER to transfer from Y to DELTA just as the pump motor reaches maximum RPM from a dead stop (see “Y-D OPEN TRANSN. TIMER” on page 5-53).

3

**ATL Starter (Across The Line)** Adjust the UP TO SPEED TIMER to delay the energizing of the valves until after the pump motor is running at speed (see “UP TO SPEED TIMER” on page 5-53). If the A contactor does not pick when a demand up is present:

- Verify that there are no faults displayed on the HC-MPU board LCD display.
- Verify that relays SAFS and SAFL are picked.
  - If neither relay is picked, check fuse F2 and then verify that the voltage measured between terminals 1 (1Bus) and 2 (2 Bus) is 120 VAC.
  - If relays SAFS and SAFL pick but the A contactor does not, check the starter overload and thermal overload contacts.
  - If relay SAFS does not pick, briefly place a jumper between 2 Bus and the SAFC screw terminal on the HC-CTL board (bypasses the safety string). If relay SAFS picks with the jumper, troubleshoot the safety string.
  - If relay SAFL does not pick, briefly place a jumper between 2 Bus and the DLAB screw terminal on the HC-CTL board (DLABR on the HC-RDR board). Make sure that relay GS on the HC-CTL board is also picked (GSR on the HC-RDR board). If relay SAFL picks with the jumper, troubleshoot the door lock string.

**Note**

If the car needs to run at low speed to adjust the valves, set the HIGH SPEED INSPECTION option to DISABLED (see “HIGH SPEED INSPECTION” on page 5-65).

## Hoistway Control Equipment Installation

This section covers the recommended procedures for installing the landing system, terminal slowdown switches, directional limit switches, hoistway access switches (if required), the hoistway access limit switch, and the emergency terminal slowdown switch.

### Installing the Landing System

Refer to the installation drawings for the type of landing system provided.

#### Installing the Landing System Control Box (LS-QUTE)

Refer to the drawings in the job prints.

- The location for the landing system box should have already been selected.
- Holes are available on both sides and on the bottom of the landing system box for mounting to any support brackets or structural channels. The mounting of the box should be very firm and solid so that knocking it out of alignment would be difficult. Use 1/4-20 hardware.
- To install the tape into the tape guides on the LS-QUTE landing system box, remove the 2 thumbscrews on the 2 guide assemblies, insert the tape and reinstall the guides and thumbscrews (tighten firmly). If the installation has the LS-QUTE car top selector with the additional sensor bracket on the rear of the tape, first remove the three 8-32 screws holding the protective 1" wide channel. This channel covers the back of the Door Zone sensors on the upper tape guide bracket. Remove the single standoff that is in the way of the thumbscrew holding the tape guide. Remove the thumbscrews holding the upper and lower tape guides, insert the tape, and reinstall the guides with the thumbscrews (tighten firmly). Reinstall the standoff (do not over-tighten) and the protective channel.
- After inserting the steel tape into the tape guides, check the location of the landing system box. The car should be at the top of the hoistway to make it easier to see if the alignment is causing any stress or binding on the tape guides. Make sure that the box is vertical and plumb with the tape. This allows for easy tape movement and avoids excessive wear on the tape guides (using a level is helpful). Be careful so as to avoid premature failure of the tape guides.
- Move the elevator to the top and bottom of the hoistway to check for smooth tape movement and to make sure that there is no excessive pressure on the tape guides. Correct any problems immediately.

### Installing the Magnetic Strips on the Steel Tape

Carefully, read and follow the Magnet Installation instructions in the job prints, but read the rest of these instructions before proceeding.

1. Before installing the magnets, clean the steel tape thoroughly with an appropriate solvent. No oil should be left on the tape as it will interfere with the adhesive backing on the magnets.
2. There are normally five lanes of magnets installed on the side of the tape facing the car. One lane consists of only the LU/DZ/DZX/LD and requires that a 6-inch magnet be installed at each floor. The other lanes have magnets which initiate slow downs or act as Absolute Floor Encoding (AFE) set points.
3. If the installation has rear doors, it may have an LS-QUTE landing system which has additional Door Zone sensors on the rear of the upper tape guide assembly. Follow the Magnet Installation instructions in the job prints and install the front and rear Door Zone magnets on the steel tape as shown.

### Installing the Hoistway Limit Switches

- The terminal landing slowdown switches should be installed and adjusted to open approximately one inch beyond the point where a normal slowdown (STU/STD) is initiated.
- The direction limit switches should be installed and adjusted to open approximately one inch beyond the terminal landings.
- The emergency terminal slowdown switch (if required) should open after the direction limit is open, but before striking the stop ring. Install and adjust the switch where it will not interfere with Inspection or Automatic operation while leveling or releveling. It must also be adjusted to achieve the required operation according to the applicable elevator code.
- Ensure that the cam that operates the slowdown and limit switches maintains the terminal slowdown switch open until the direction limit switch and emergency terminal slowdown switches (if required) are open.
- Ensure that the terminal slowdown, direction limit and emergency terminal slowdown switches are held open for the entire run-by or over-travel of the elevator.
- The hoistway access limit switch (if required) should be installed and adjusted to open and stop the elevator (in the down direction) when the top of the elevator is approximately level with the top landing (when the top hoistway access switch is activated while on Access or Inspection operation).

3

### Door Position Monitor Switch (If used)

If you are in a jurisdiction where ASME A17.1 - 1996 or later is being enforced, Door Position Monitor switch(es) connected to the DPM and/or DPMR inputs must be added to monitor the position of the closed doors. This must be a separate physical limit switch that makes up approximately 1 to 2 inches before the doors lock. Please refer to the DOOR POSITION MONITOR and DOOR CLOSE LIMITS options on [page 5-54](#).

## Complete the Installation and Field Wiring

Refer to the job prints and complete the installation of equipment and field wiring to the controller, including:

- Car Operating Panel (COP) switches and indicators
- Fire Service detectors and indicators
- Position indicators
- Hall switches and indicators

**Check for shorts**      With the power turned OFF and prior to inserting the plug-in terminals into the boards:

- Check all of the call and PI terminals for shorts to ground (1 bus).
- Check all of the call and PI terminals for shorts to the 2 bus.

**Check with power ON**      With power turned ON at the main power disconnect:

- Jumper each of the call terminals, one-by-one, to ground (1 bus). Verify that no fuses blow, especially F2, F2H and F2CC.

**Plug in the terminal connectors**      With the power turned OFF at the main disconnect:

- Plug the call and PI terminal connectors into the PC boards.

## Preparing the Car to Run on Test/Normal Mode

1. Verify that the Hoistway Door and Car Door Bypass switches work properly.
  - Turn the switches ON. Verify that the indicators on the HC-CTL board turn on and that the car will run with doors open on Cartop Inspection only.
  - Turn the Hoistway Door and Car Door Bypass switches OFF. Verify that the car will not run with doors open.
2. Verify that the door operator is operating properly with all door equipment (clutches, rollers, etc.) properly adjusted with the correct running clearances and speeds.
3. Verify the door limits sequencing - DOL, DCL and DPM.
4. Make sure the car doors are closed and that all hoistway doors have been closed and locked.
5. Ensure that the car gate and door locks are made. If there is rear door functionality, then also ensure that the rear gate and door is made.
6. Run the car through the hoistway, on Cartop Inspection, to make sure that the hoistway is completely clear.
7. Verify that the landing system has been installed according to the installation instructions. Check PI stepping, floor encoding, leveling and door zone.
8. Verify that the limit switches are operating properly.
9. Verify that the Access limit switches operate properly (car stops in the proper location).
10. Proceed to Section 4 Final Adjustment.







## Quick Topics

- In this Section
- Onboard Diagnostics
- Absolute Floor Encoding
- Registering Car Calls
- Test Mode
- Running on Test/Normal
- Final Adjustments on Test
- Final Adjustments on IND
- Final Adjustments on Normal
- Release to Normal Operation



## Final Adjustment

4

### In this Section

Before the car can be released to normal operation, final adjustments and code-mandated testing must be completed and approved. At this point, all of the steps in Section 3 should have been completed. Please read Section 5 before proceeding: it explains the adjustment and troubleshooting tools available. This section describes:

- **Diagnostics on the PC boards:** Information about diagnostic messages and status LEDs on the PC boards ([see page 4-2](#)).
- **Absolute Floor Encoding:** A description of car behavior with and without absolute floor encoding ([see page 4-2](#)).
- **Registering Car Calls:** How to register car calls ([see page 4-3](#)).
- **Test Mode:** A description of car behavior on Text Mode ([see page 4-4](#)).
- **Running on Test/Normal:** Instructions for beginning operation on Test and Normal modes ([see page 4-5](#)).
- **Final Adjustments on Test Mode:** Instructions for making final adjustments ([see page 4-6](#)).
- **Final Adjustments on Independent Service:** Instructions for making final adjustments on Independent Service ([see page 4-7](#)).
- **Final Adjustments on Normal Operation:** Instructions for making final adjustments on Normal Operation ([see page 4-8](#)).
- **Release to Normal Operation:** Final checks before releasing the elevator to normal operation ([see page 4-10](#)).

## Diagnostic Messages and Input/Output Signals

To speed up final adjustment and troubleshooting, become familiar with the Status and Error Messages (see [“Status and Error Messages” on page 6-3](#)) and Input/Output signals (see [“Alphabetized Flags/Variables and Their Locations” on page 5-9](#)).



### Note

It will also be helpful to become familiar with the Motion 2000 Controller's computer (see [“The HC-MPU Main Processor Unit” on page 5-2](#)) and Diagnostic Mode (see [“Diagnostic Mode” on page 5-6](#)).

### Onboard Diagnostics

**Status LEDs** - The Motion 2000 controller boards (HC-CTL, HC-MPU, HC-DVR and HC-RDR boards) are equipped with diagnostic LED's, which provide visual information regarding the computer's inputs and outputs. A listing of the indicators on each board can be found in PC Board Quick References (see [“PC Board Quick References” on page 6-35](#)).

**LCD Display** - When the Motion 2000 Hydraulic Controller's computer (HC-MPU) is in the DIAGNOSTIC MODE, with switches F1 - F8 in the down position, the LCD display provides a description of normal and abnormal conditions. When the LCD displays NORMAL, in the car status field, the system is ready for normal operation. A complete listing of the status and error messages, their meaning, probable cause and needed response are found in the Status and Error Messages table (see [“Status and Error Messages” on page 6-3](#)).

The computer displays abnormal conditions in the same priority that the computer evaluates them. For example, if the safety circuit is open and the system is also on Fire Service, the computer will first show that the safety circuit is open and will expect this problem to be corrected first. When the safety circuit problem has been corrected and the computer has recognized the safety input, the diagnostics will then show the Fire Service indication. After successfully bringing in the Fire Service input and Fire Service Reset, the computer will then show NORMAL on the LCD display, provided that the system is not on some other function such as Independent Service or Cartop Inspection operation. The display will show NORMAL only if everything is normal. If the LCD display is showing any other message, an abnormal condition exists.

### Absolute Floor Encoding

Absolute floor encoding allows the controller to read encoding vanes or magnets at each landing and thereby identify the floor. With absolute floor encoding, the behavior of the car when power is turned ON is as follows:

- If the car is not at a landing when power is turned ON, the controller will generate a Down/Up direction command and the car will move toward the closest landing, provided that all abnormal conditions have been corrected. When the car reaches a landing and is within the Door Zone (diagnostic LED DZF is On) with leveling completed (diagnostic LEDs ULM and DLM are Off) the controller reads the floor code vanes or magnets and corrects the Position Indicator. If the car is on Automatic Operation, and if a home floor has been designated, the car will move to the home landing at this time.
- If the car is at a landing, within the Door Zone (diagnostic LED DZF is On) with leveling completed (diagnostic LEDs ULM and DLM are Off) when AC power is turned ON, the controller will read the floor code vanes or magnets at the landing and correct the Position Indicator. Again, if the car is on Automatic Operation and if a home floor has been designated, the car will move to this landing to park.

## Registering Car Calls

To place a call from the controller (or the hand-held):

1. Place the F5 function switch up (all others down).
2. If Controller Utilities Menu is not displayed, press N push button.
3. Press S push button. Front Call Registration is displayed. Refer to the illustration below.

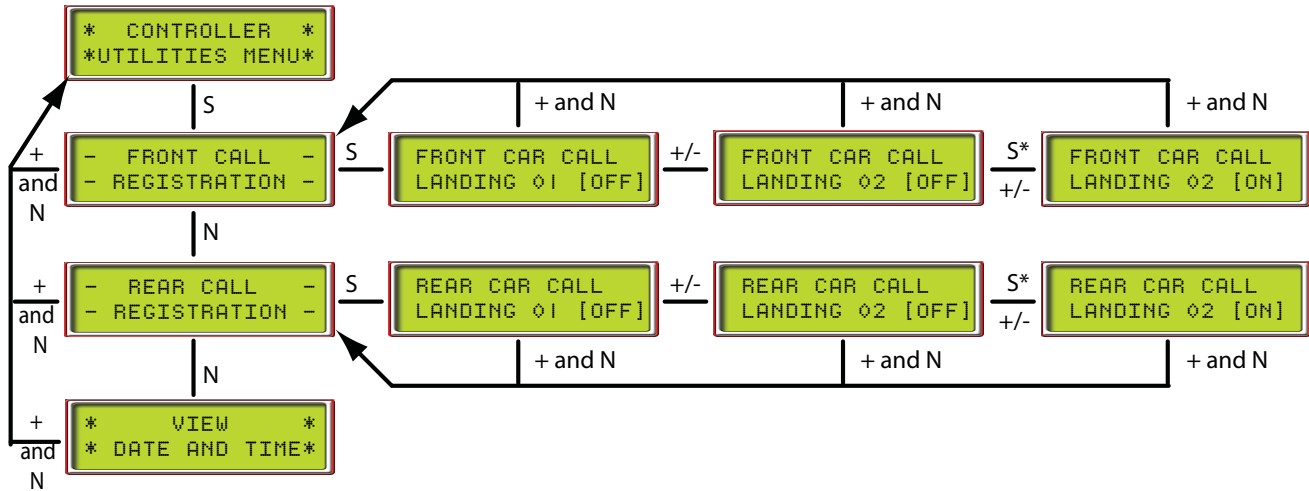
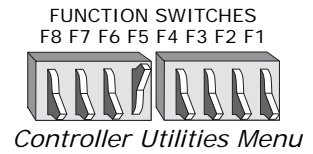

4. Press +/- push buttons to increment or decrement floor numbers.
5. Press and momentarily hold S push button to register calls: displays [ON] while held.
6. Press + and N push buttons together to back out of the current display.

## Placing Calls Using a Fused Jumper Wire

If your system uses discrete call inputs to a Universal I/O board, you can register car calls from the controller using a fused jumper wire (1A, fast-blow):

1. Connect a fused jumper wire to system common (Terminal 1).
2. Momentarily touch the other end of the wire to the desired car call terminal on the HC-UIO board. (Multiple calls can be placed before the car begins to move.)

The car may move immediately after a car call is registered or it may wait for a non-interference timer to elapse first (if it has not already elapsed). In TEST mode, if multiple calls are registered, the car will not automatically move from call to call unless a jumper is placed continuously between 1 bus and terminal DCB on the HC-CTL board (or 1 bus to the terminal of the last call registered).



### Caution

Never short any bus except system common to a UIO board car call terminal. Any voltage applied while the terminal is in the ON state will damage the circuit board.

Continue placing calls to evaluate performance and accuracy and to ensure the car does not overshoot terminal landings.

## Test Mode Operation

The purpose of TEST mode is to allow easy and convenient operation of the car so that the final adjustments can be made without cycling the doors. When the elevator is operated in the TEST mode, the elevator doors do not open. The door open functions are disabled during TEST mode operation.

The car is put into TEST mode by placing the TEST/NORMAL switch on the HC-CTL Main Control board in the TEST position. Note that when the TEST/NORMAL switch is in the TEST position, it puts the car into Test Mode, provided that the Car Top Inspection and MACHINE ROOM INSPECTION switches are in the NORM or normal positions. In that case, the LCD should show “TEST MODE” and not “NORMAL.” If the expected indication is not displayed, check to see what message is being displayed and correct the problem. Operation while in TEST mode should be easy to understand by knowing the following:

1. Every time the car stops, a non-interference timer is started and the timer must elapse before the car can move again. Once the timer has elapsed, the car will move as soon as the next car call is registered. If a car call is placed right after the car stops, the non-interference timer must elapse and then a jumper must be placed between 1 bus and terminal DCB on the HC-CTL board (or 1 bus and the call terminal) before the car will move.
2. In TEST mode, if multiple calls are registered, the car will not automatically move from call to call unless a jumper is placed continuously between 1 bus and terminal DCB on the HC-CTL board (or 1 bus to the terminal of the last call placed). While using TEST mode, for convenience you may want to leave a jumper continuously between 1 bus and terminal DCB.
3. If a jumper from terminal 1 is touched to the car call input for the floor where the car is located, it will reestablish the non-interference timer and it must elapse before the car can move again.
4. If the elevator is trying to level, it will not pick high speed and leave the landing until it has completed the leveling process. If the car overshoots landings, the valves and/or direction limits at terminal landings may need to be adjusted.
5. If any of the inputs that open the door are active (Safety Edge On, Photo Eye On, Car Call input for the floor matching the Position Indicator jumpered to 1 bus, etc.) the car will not leave the landing.
6. Slowdown switch inputs (DSL1 and DSL2 for the bottom terminal and USL1 and USL2 for the top terminal) should never be inactive at the same time when the doors are closed and locked and the safety circuit is closed.

## Running on Test/Normal Mode



### Caution

If the door operator is not working, pull the door fuses and close the doors so that the door clutch will not hit any of the door lock rollers. Take whatever steps are necessary to keep the installation safe, but make sure that the car top is still accessible after closing all of the doors.

1. On Inspection, move the car to the bottom landing.
2. Verify that the car is in door zone (PI = 1) and indicators ULM and DLM are OFF and DZF is ON.
3. Place the Cartop Inspection, In-car Inspection and Access Enable switches in the Normal position.
4. On the HC-CTL Control board, place the CONTROLLER TEST SW in the TEST position.
5. Place the MACHINE ROOM INSPECTION MODE switch in the NORM position. If the LCD display does not show Test Mode, see what message is being displayed and correct the problem.

NOTE: If the car is not completely wired (temporary), jumpers will be required. Check the following:

- wire removed from screw terminal DCL on HC-CTL board.
  - wire removed from screw terminal PHE on the HC-CTL board.
  - jumper from 2 bus to screw terminal DPM on HC-CTL board.
  - jumper from 2 bus to screw terminal DOL on the HC-CTL board.
  - jumper from 2 bus to screw terminal FRS on the HC-CTL board.
  - jumper from 2 bus to panel mount terminal EPI (if present).
6. If the car is not at a landing, it will move to a landing. If the car is at a landing but not in the door zone, either the ULM or DLM input (diagnostic LEDs ULM or DLM) is ON, the car should perform a relevel. If the relevel is not successful, check the following:
    - If the diagnostic LEDs ULM or DLM are ON, but the car does not move, verify that there are no faults displayed on the HC-MPU LCD screen. Also verify that relays SAFS and SAFL are picked and the up/down direction limit switches are in their proper states.
    - If the car is trying to level, it will not leave the landing for a call until the leveling is complete.

**Automatic Mode Fault Bypass** For the purpose of testing and adjustment, this option allows redundancy faults to be bypassed when the controller is on Automatic operation. In order to use this option, a jumper must be placed on JP1 (see “[Controller System Menu](#)” on page 5-65).

1. Place the controller on System Mode (see “[F3: System Mode](#)” on page 5-59).
2. Press the **N** push button to display Controller System Menu and then press the **S** push button to select (see “[Controller System Menu](#)” on page 5-65).
3. Press the **N** push button to display AUTOMATIC MODE FAULT BYPASS. JUMPER MUST BE INSTALLED TO ACTIVATE.
4. Press the **S** push button to select BYPASS ON.

## Final Adjustments on Test Mode

The following final adjustments should be made with the elevator operating on Test mode (Controller Test Switch on the HC-CTL board in the TEST position). The LCD display should indicate TEST MODE.

### Hydraulic Valves

Adjust hydraulic valves for proper speed, acceleration, deceleration, etc. and check contract speed. A software controlled timer (SOFT-STOP TIMER option) automatically provides pump motor overrun for Soft-Stop operation. Ensure that the Soft-Stop Timer is set to the desired value for it to be on and to NONE for it to be off. If the car needs to run at low speed to adjust the valves, set the HIGH SPEED INSPECTION option to DISABLED (see [“HIGH SPEED INSPECTION”](#) on page 5-65).

### Slowdown and Limit Switches

Disconnect the stepping switch inputs (terminals STU and STD on the HC-CTL board for 3 or more landings) and verify proper operation of all slowdown and limit switches for slowing and stopping the car at both terminal landings.

### Motor Limit Timer

A motor limit timer is provided to take the car to the bottom landing and open the doors if the motor is operating for too long.

### Valve Limit Timer

The same is true for the valves with the down valves being turned off and the doors re-enabled if the car is at a floor.

### Relevel Operation

If the car re-levels up after stopping at the floor, it will respond normally (instantly) the first time it re-levels up. Further re-leveling at that landing will be delayed by a computer-controlled timer (usually 3 seconds). This process will repeat every time the car runs to another floor (the first up relevel is always normal, not delayed). Down leveling is always normal and not affected by this timer.

### Final Adjustments on Independent Service

The following final adjustments should be performed with the elevator operating on Independent Service.

- Place the CONTROLLER TEST SW on the HC-CTL board in the NORM position.
- Place the Independent Service switch in the IND position.
- Verify that the IND indicator on the HC-MPU board is ON and the LCD display indicates INDEPENDENT SERVICE.

### Door Operator Adjustments

Complete the final door operator adjustments. Verify smooth opening and closing. Doors can be opened at 3" before the floor or at the floor (see [“PRE-OPENING?” on page 5-23](#)). Hydraulic elevators are usually set up to open the doors only after the car stops, but pre-opening is available. Verify the operation of the photo eye and/or safety edge, door open and close buttons.

### Door Open/Close Protection

Verify proper door open protection and door close protection operation.

- Door open protection: If the doors do not open (DOL goes low) after several seconds, the car will give up and continue to the next call (see [“DOOR OPEN PROTECTION TIMER” on page 5-27](#)).
- Door close protection: After the car starts to close the doors and the doors do not lock, it will recycle the doors open and attempt to close the doors three times before a DLK fail error is generated and DOOR CLOSE PROTECTION TIMER ELAPSED is displayed on the LCD.

4

### Stuck Button Protection

Verify proper stuck button protection operation for both car calls and hall calls.

## Final Adjustments on Normal Operation

The following final adjustments should be performed with the elevator operating on Normal operation.

- Place the CONTROLLER TEST SW on the HC-CTL board in the NORM position.
- MACHINE ROOM INSPECTION MODE switch on the HC-CTL board in the NORM position.
- Place the Independent Service switch in the OFF position.
- Verify that the LCD display indicates NORMAL.

## Hall Calls

Place hall calls for all of the landings and make sure that all hall calls function properly.

## Ride and Performance

Run the car to all stops:

- Verify car call assignments
- Check for overshoot
- Verify door operation at all floors
- Check for proper ride quality.

## Recheck

Recheck the operation of the following on Normal operation:

- Doors
- Car calls
- Hall calls
- PIs
- Gongs and Lanterns
- Photo eye
- Safety edge
- Door open button

## Options

Verify the operation of the following options: Independent Service, Fire Return Phase 1 (Main Floor and Alternate Floor operation, if provided), Fire Phase II In-Car operation, and any other options provided.

## Random Call Testing

Sabbath operation can be used to perform random call testing (refer to the SAB input, [see “Spare Inputs Menu Options” on page 5-29](#)).



## Remote Governor Testing (Roped Hydro)

For a roped hydro installation, the following procedure describes the remote testing procedure for a Wittur Model OL35-NA governor.

### Static Testing:

Refer to the Operating Instructions supplied with the governor. Section #4 of these instructions should be closely adhered to.

1. Locate the elevator controller slide switches labeled GOVERNOR TRIP #1, GOVERNOR TRIP #2, GOVERNOR RESET #1 and GOVERNOR RESET #2.
2. Slide both switches GOVERNOR TRIP #1, GOVERNOR TRIP #2 from the OFF position to TRIP position.
3. Observe that the safety circuit opens and the elevator will not move.
4. In order to return the system to normal operation, return both the GOVERNOR TRIP slide switches to the OFF position and then move the slide switches labeled GOVERNOR RESET #1 and GOVERNOR RESET #2 from the OFF position to the RESET position.
5. Finally move the slide switches GOVERNOR RESET #1 and GOVERNOR RESET #2 from the RESET position to the OFF position and observe that the safety circuit is now made and elevator can operate normally.

4

### Dynamic Testing:

Refer to the Operating Instructions supplied with the governor. Section #4 of these instructions should be closely adhered to.

1. Locate the elevator controller slide switches labeled GOVERNOR TRIP #1, GOVERNOR TRIP #2, GOVERNOR RESET #1 and GOVERNOR RESET #2.
2. Move the elevator at contract speed in the down direction and simultaneously slide both switches GOVERNOR TRIP #1 and GOVERNOR TRIP #2 from the OFF position to TRIP position.
3. Observe that the safety circuit opens and the elevator stops and will not move.
4. In order to return the system to normal operation, return both the GOVERNOR TRIP slide switches to the OFF position and then move the slide switches labeled GOVERNOR RESET #1 and GOVERNOR RESET #2 from the OFF position to the RESET position.
5. Finally move the slide switches GOVERNOR RESET #1 and GOVERNOR RESET #2 from the RESET position to the OFF position and observe that the safety circuit is now made and elevator can operate normally.

This completes testing of remote governor activation circuitry.

## Release to Normal Operation

Final testing must be successfully completed before the car may be released for passenger operation.



### Danger

Before the Elevator can be turned over to normal use, it is very important to verify that no safety circuit is bypassed. The items to be checked, include, but are not limited to:

- Verify that the hierarchy of the inspection inputs is correct. Car top inspection must take priority over in-car, hoistway access and machine room inspection modes. In-car must take precedence over hoistway access and machine room inspection. Hoistway access must take priority over machine room inspection.
- The FAULT jumper on the HC-CTL board is removed.
- No jumper between terminals 2 and SAFH (HC-CTL).
- No jumper between terminals 2S and DLAB (HC-CTL).
- No jumper between terminals 2S and DLAT or DLMS (HC-CTL).
- No jumper across any of the limits (HC-DVR).
- No jumper between terminals SAFH and SAFC (HC-CTL).
- The Automatic Mode Fault Bypass option is set to BYPASS OFF.
- The F3 switch on the HC-MPU board is down.



## Quick Topics

- In this Section
- Main Processor
- Computer Security
- Diagnostic Mode
- Program Mode
- Basic Features
- Fire Service
- Door Operation
- Timers
- Gongs/Lanterns
- Spare Inputs
- Spare Outputs
- Extra Features
- Additional Car Options
- External Memory Mode
- System Mode



## The Computer

5

### In this Section

The Computer is the primary programming and adjustment tool for the Motion 2000 system. This section provides the information you need to use the Computer, including:

- **HC-MPU Main Processor:** Describes the indicators, switches, buttons, connectors and display on the HC-MPU Main Processor board (see [page 5-2](#)).
- **Computer Security:** Describes the optional password protection system (see [page 5-5](#)).
- **Diagnostic Mode:** Using the onboard diagnostics for troubleshooting (see [page 5-6](#)).
- **Program Mode:** Describes how to program the many options available, including:
  - **Basic Features Menu Options** (see [page 5-17](#))
  - **Fire Service Menu Options** (see [page 5-20](#))
  - **Door Operation Menu Options** (see [page 5-22](#))
  - **Timer Menu Options** (see [page 5-26](#))
  - **Gongs/Lanterns Menu Options** (see [page 5-28](#))
  - **Spare Inputs Menu Options** (see [page 5-29](#))
  - **Spare Outputs Menu Options** (see [page 5-39](#))
  - **Extra Features Menu Options** (see [page 5-48](#))
  - **Additional Car Options Menu** (see [page 5-53](#))
- **External Memory Mode:** How to view data stored in external memory (see [page 5-55](#)).
- **System Mode:** Describes system mode options, e.g., Building Security, Passcode Request, Load Weighing and ASME A17.1 2000 Fault Bypass (see [page 5-59](#)).
- **Duplexing:** Describes how to troubleshoot communication problems (see [page 5-74](#)).

## The HC-MPU Main Processor Unit

The computer on the Motion 2000 Hydraulic Elevator Controller has been designed for easy communication between the mechanic and the controller and between the controller and other computers or data terminals. The computer is used for diagnostic troubleshooting and for programming the controller.

Figure 5.1 HC-MPU Main Processor Unit

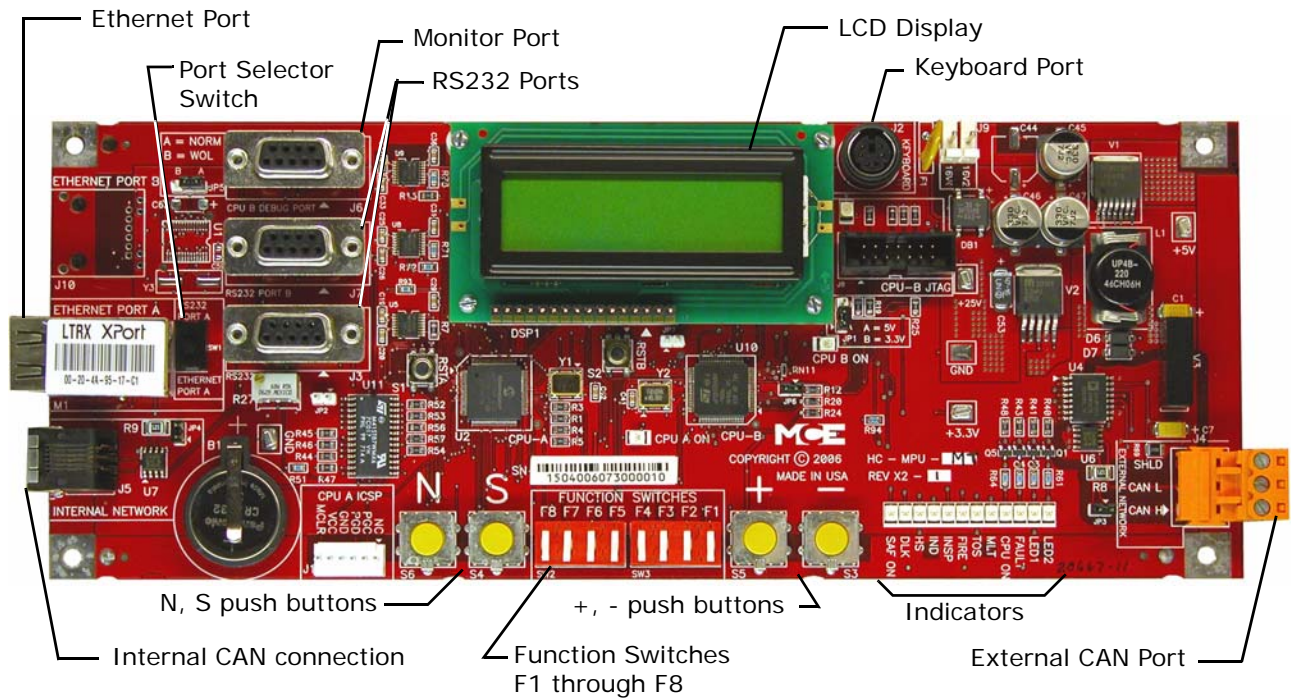

Figure 5.1 shows the indicators, push buttons and terminals on the main processor unit.

### Indicators

**CPU-A, CPU-B** When steadily illuminated, this light shows that the computer is functioning normally and completing its program loop successfully. Pressing the COMPUTER RESET button will cause the COMPUTER ON light to turn *OFF* and the light will stay *OFF* while the RESET button is depressed. The computer is equipped with a watchdog feature that will shut down the controller if the program loop cannot be completed (software system failure). If the COMPUTER ON light is OFF or flashing continuously, it means that the computer board is malfunctioning.

**Diagnostics LCD Display** The 32-character LCD (Liquid Crystal Display) displays various information depending on the positions of the F1-F8 switches. Diagnostic mode is accessed when all of the switches are in the down position. The LCD display shows an elevator status message, the car position, the contents of the computer's internal memory and communication status.

**Status Indicators** These lights show the status of the elevator. Table 5.1 shows a list of these lights and their meanings.







**Table 5.1 Status Indicators**

Indicator	Description
SAF ON	Safety On - Safety circuit is made
DLK	Doors Locked - Door lock contacts are made
HS	High Speed - The elevator is running at high speed
IND	Independent Service - The elevator is on independent service
INSP	Inspection / Access - The elevator is on cartop inspection or hoistway access
FIRE	Fire Service - The elevator is on fire service operation
TOS	Timed Out of Service - The elevator has been timed out of service
MLT	Motor/Valve Limit Timer - The motor/valve limit timer has elapsed
CPU ON	Computer On - The MC-MPU processors are functioning properly
FAULT	Fault - A fault condition exists.
LED1	Reserved
LED2	Reserved

### Switches, Buttons & Adjustments

**Function Switches F1 - F8** The function switches are used to select the Main Computer's operating and programming modes as indicated in the following table.

**Table 5.2 Function Switches**

Function Switches F8 F7 F6 F5 F4 F3 F2 F1	Description
	<b>All OFF = Diagnostic Mode:</b> Use for diagnosing and troubleshooting system problems (see <a href="#">"Diagnostic Mode"</a> on page 5-6).
	<b>F1 ON = Program Mode:</b> Use to view and change the settings of parameters and programmable options (see <a href="#">"F1: Program Mode"</a> on page 5-14).
	<b>F2 ON = External Memory Mode:</b> Use to diagnose problems by viewing external memory flags (see <a href="#">"F2: External Memory Mode"</a> on page 5-55).
	<b>F3 ON = System Mode:</b> Use to program System functions, e.g. elevator security and load weigher settings (see <a href="#">"F3: System Mode"</a> on page 5-59).
	<b>F4 ON = Messages and Floor Labels:</b> Use to program the CE fixture displays (see <a href="#">"F4: Messages and Floor Labels"</a> on page 5-66).
	<b>F5 ON = Controller Utilities Menu/Monitoring and Reporting Menu:</b> Use to register front and/or rear car calls, set the controller's date and time, view the event log, CAN bus data and Monitoring and Reporting menu (see <a href="#">"F5: Controller Utilities/Monitoring and Reporting"</a> on page 5-67).
	<b>F8 ON = Status Display:</b> Shows the software version, eligibility map and current load if applicable (see <a href="#">"Status Displays"</a> on page 5-4).

**RSTA - RSTB** Pressing the *RESET* button will cause the computer to reset. If the elevator is running, the controller will drop the safety relay and bring the elevator to an immediate stop. The elevator will then go to the terminal landing (or to the next landing if the controller has the absolute floor encoding feature) to correct its position before it can respond to any calls. Existing calls and P.I. information will be lost each time the computer is reset.

**N, S, +, - Push Buttons** The push buttons allow the mechanic to view and change data in the computer memory. These push buttons have different functions depending on the current mode (Diagnostic mode [see “Diagnostic Mode” on page 5-6], Program mode [see “F1: Program Mode” on page 5-14], External Memory mode [see “F2: External Memory Mode” on page 5-55], or System mode [see “F3: System Mode” on page 5-59], CE Labels [see “F4: Messages and Floor Labels” on page 5-66]).

**RS-232 Port B / Ethernet Port Selector Switch** Selects between the RS-232 Port B and the Ethernet Port. Only one can be used.

## Connectors

**Internal CAN Port** Controller Area Network port used for communication inside the controller cabinet.

**External CAN Port** Controller Area Network port used for communication outside the controller cabinet, e.g. to the cartop.

**RS-232 Ports A and B** RS-232 communication ports A and B.

**Ethernet Port** Ethernet port used for Local Area Network (LAN) and/or Internet communication.

**Monitor Port** Used to connect to a computer monitor (for diagnostics only).

**Keyboard Port** Used to connect to a standard computer keyboard.

## Status Displays

To access the Status Displays, place function switch *F8* in the up position (F1 through F7 must be down). Press the *N* push button to cycle through the available status displays.

The following system status displays are available for viewing on the LCD display:

- **Software Version** - Main processor software version number.
- **Eligibility Map** - Door access for each floor (F = front, R = rear, B = both, ● = no access). Read left to right - floors 1 through 16 in the top row, floors 17 through 32 in the bottom row. Please see “CAR SERVES FRNT/FLR 1? (simplex)/THIS CAR SERVES FRNT/FLR 1? (duplex)” on page 5-18 and see “CAR SERVES REAR/FLR 1? (simplex) / THIS CAR SERVES REAR/FLR 1? (duplex)” on page 5-18 for programming instructions.
- **Current Load** - If an analog load weigher is used, the current load in the car as a percentage of full load is displayed (see “Load Weigher Thresholds” on page 5-62).

## Computer Security

A computer security system is available for the Motion 2000 controllers. The system requires the user to enter a passcode before the controller's parameters can be adjusted.

The controllers are shipped without the security system. However, the security system can be purchased through MCE's Technical Support Department. Complete installation instructions are provided with the modification package. The next few paragraphs explain how the security system works after it is installed.

Note

**This message is not related to Computer Security.** If this message is seen on the LCD screen, it means that the Passcode Request Option has been activated and that a passcode is required in order to run the elevator on any mode of operation other than Inspection. [Please refer to "Passcode Request Menu" on page 5-61](#) for more information.

```
PASSCODE REQUEST
PI 8 20:10001000
```

### Password

There are two sections that are secured by an 8-digit, alpha-numeric code chosen by the customer, Program Mode and System Mode.

When either of these two sections is accessed, the LCD display will show:

```
ENTER PASSWORD:
00000000
```

The password is entered using the push buttons as follows:

- N Push button Change the position of the cursor to select a digit to set.
- + Push button Increment the selected digit by one.
- Push button Decrement the selected digit by one.
- S Push button Check for a match (ENTER).

If an invalid code is entered, the operator will be prompted to re-enter the code. Once a valid code has been entered, access is granted to the programming options and the password will not have to be reentered until the Password Timer expires.

## Diagnostic Mode

Onboard Diagnostics are designed to aid in evaluating the status of the control system. Onboard Diagnostics help to pinpoint the cause of elevator malfunctions.

### Getting into Diagnostic Mode

Diagnostic mode is initiated by placing Function Switches F1 - F8 in the down position. A description of the LCD display format and the function of the *N*, *S*, +, and - push buttons during Diagnostic mode follows.

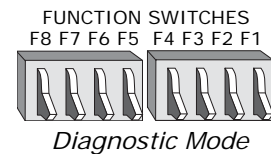

### Function of *N* Push Button

The *N* push button selects the digit of the computer memory address, which is displayed on the second line of the LCD. For example, for the following display, pressing the *N* push button once will cause the 2 of the address 20 to begin blinking. By continuing to press the *N* push button, the 0 of address 20 will begin to blink. The cycle will continue while the *N* push button is being pressed. Once the digit to be changed is blinking, the address can then be modified using the + and - push buttons as described below.

```
NORMAL OPERATION
PI 8 20:10110011
```

The data (8 digits) that corresponds to the memory address, is displayed to the right of the address (see “Computer Internal Memory” on page 5-7). This display will change as the memory address changes.

### Function of *S* Push Button

The *S* push button ends the ability to change the address by stopping the digit from blinking. If the *S* push button is not pressed, the selected digit will stop blinking automatically after a period of about 20 seconds.

### Function of + Push Button

The + push button modifies the digit of the computer memory address selected by the *N* push-button. If the + push button is pressed, the selected digit is incremented by one. The data display will also change as the address changes. For example, if the 0 of the address 20 is blinking, pressing the + push button once will change the address from 20 to 21. Pressing the + push button several more times will change the address to 22, 23, 24, etc., up to 2F and then back to 20 again. If the 2 of address 20 is blinking, pressing the + push button once will change the address from 20 to 30. Pressing the + push button several more times will change the address to 40, 50, 60, etc., up to F0. Once the address has reached F0, pressing the + push button will cause the address to begin back at 00.

### Function of - Push Button

The - push button also modifies the digit of the computer memory address selected by the *N* push button. If the - push button is pressed, the selected digit is decremented by one. The data display will also change as the address changes. For example: If the 0 of address 20 is blinking, pressing the - push button once will change the address from 20 to 2F. Pressing the - push button several more times will change the address to 2E, 2D, 2C, etc., back to 20 again. If the 2 in the address 20 is blinking, pressing the - push button once will change the address from 20 to 10. Pressing the - push button several more times will change the address to 00, F0, E0, etc., back to 00. Once the address has reached 00, pressing the - push button will cause the address to start over at F0.



## Format of LCD Display

The multi-functional alphanumeric LCD display shows car status and can also be used for diagnostic purposes to display the contents of computer memory. The figure shows the various parts of the LCD in Diagnostic mode.

**Normal Display** For simplex controllers, the letter D in the drawing will not appear on the LCD and instead that part of the display will always be blank. For a duplex controller, this part of the display provides information about the communication between the controllers and about the dispatching. One of the following codes should appear:

**S** Indicates that this computer is acting as the slave to the dispatching computer. Hall call assignments are received from the dispatching computer through the communication cable.

**D** Indicates that this computer is acting as the dispatcher. It is responsible for assigning hall calls to itself and to the other controller.

**Blank** If this part of the display is blank, it denotes that communication has not been established between the two cars (see Section 6 for information on identifying and solving communication problems).

**Status / Error Message** The top line of the LCD display shows the prevailing status of the elevator. The message is scrolled if it is larger than the space available. There is a status message for each special operation (e.g., Fire Service). There are also messages for most error conditions (e.g., open safety string). For a list of these status and error messages including a description and troubleshooting suggestions see [“Status and Error Messages” on page 6-4](#).

**Elevator Position** The underlined section in this display shows current elevator position relative to the bottom floor. The number 1 denotes the lowest landing in the elevator system.

**Computer Internal Memory** The underlined section in this display shows the computer internal memory address (2 digits) and the data (8 digits) at that address. The colon character (:) separates the address from the data. The address is changed by first pressing the *N* push button, then the + and - pushbuttons.

Each of the 8 data digits (flags) corresponds to a particular elevator signal or condition. There are 8 pieces of information about the elevator at each memory address. Each data digit is either one or zero. One indicates the signal or condition is *ON* and zero indicates it is *OFF*.

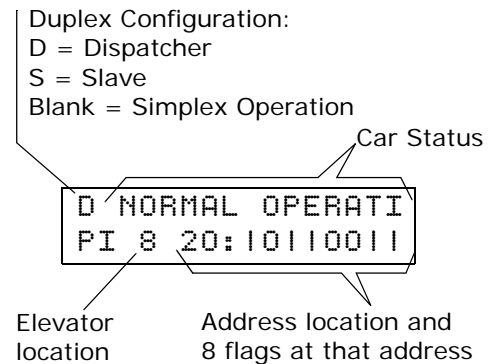

```
CAR IN TEST MODE
PI 8 20:10110011
```

```
D NORMAL OPERATI
PI 8 20:10110011
```

```
D NORMAL OPERATI
PI 8 20:10110011
```



The Computer Internal Memory Chart (Table 5.3) indicates the meaning of these data digits at different addresses.

For example, the internal memory display might look like this:

D NORMAL OPERATI
PI 8 29:11110000

The address on the display is 29; the data at that address is 11110000. To figure out what this means, simply match up the data digits with row 29 of the Computer Internal Memory Chart:

Display Data:    1    1    1    1    0    0    0    0  
 Row 29:        DNDO LD    DPD    DDP    UPDO    LU    UPD    UDP

Notice that the DNDO, LD, DPD and DDP signals are *ON* and the UPDO, LU, UPD and UDP signals are *OFF*.

**Table 5.3 Computer Internal Memory Chart**

FLAGS AND VARIABLES								
ADD	8	7	6	5	4	3	2	1
10:	DOLMR	PHER	DZR	DOLR	DBCR	DOBR	GEUR	GEDR
11:	TFAR	DCR	UCR	CCR	NDSR	FDCR	DHOR	DOIR
12:	DCFR	DCPR	DOFR	LOTR	GHTR	HCTR	CCTR	SDTR
13:	DOCR	SER	DCLCR	CSBR	DCCR	NUDGR	NDGBPSR	DSHTR
20:	DOLM	PHE	DZ	DOL	DBC	DOB	GEU	GED
21:	TFA	DC	UC	CC	NDS	FDC	DHO	DOI
22:	DCF	DCP	DOF	LOT	GHT	HCT	CCT	SDT
23:	DOC	SE	DCLC	CSB	DCC	NUDG	NDGBPS	DSHT
24:	VCI	FRA	FCS	FRS	DNS	UPS	STD/R0	STU/R1
25:	SCE	FCCC	FCHLD	HLI	VCA	EXMLT	FWI	PIC
26:	LFP	UFP	NYDS	CCH	DIN	DPR	GTDE	GTUE
27:	HD	FCOFF	DHLD	IND	IN	DLKS	MLTP	MLTDO
28:	LLW	DLK	DDF	SUD	ISR	INCF	REAR	LLI
29:	DNDO	LD	DPD	DDP	UPDO	LU	UPD	UDP
2A:	DMD	DCB	UCB	CCB	DMU	DCA	UCA	CCA
2B:	TOS	MLT	VLT	SST	H	HSEL	DSH	RUN
2C:	DZP	STC	SAF	HCR	HCDX	CCD	ISV	ISRT
2D:	TEMPB	UFQ	DZORDZ	FCSM	FRM	FRSS	FRAS	FRC
2E:	SD	SDA	DSD	BFD	SU	SUA	USD	TFD
2F:	FRBYP	FRON	HYD1_TRCO	ECC	CD	ECRN	EPR	PFG
30:	R4	R2	R3	FREE	DEADZ	DHLDI	PH1	NDGF
31:	CTLDOT	CTLF	CTL	ALV	EPSTP	AUTO	EPRUN	EPI
33:	API	SAB	TEST	DHENDR	DHEND	CTST	HOSP2	HOSP
38:	HML	SLV	CCC	CNFG	DLI	DLW	LWCE	HLW
42:	COMMUNICATION TIME-OUT ERROR COUNT							
43:	COMMUNICATION CHECKSUM ERROR COUNT							

## Troubleshooting Using the Computer's Internal Memory

Examining the computer memory (as in the example above) is a useful step in troubleshooting elevator problems. It is possible to find out if the controller is receiving input signals correctly and if it is sending out the proper output signals. It is also possible to look up each of the computer output and input signals shown in the Job Prints.

The following example illustrates how to use [Table 5.3 on page 8](#) and [Table 5.4 on page 9](#) to check a signal in the computer internal memory.

Example problem: the photo eye will not cause the doors to reopen.

1. Look at [Table 5.4 on page 9](#). Find the abbreviation or mnemonic for Photo Eye input. The table shows that the mnemonic for Photo Eye input is PHE and provides an Address (20) and Position (7) for the signal. This will show where to look for the signal on [Table 5.3 on page 8](#) and on the computer display.
2. Notice on [Table 5.3 on page 8](#) that PHE is indeed in position 7 on row 20.
3. Now that the address and position have been determined, look up the PHE signal on the computer. First, change the address on the display to address 20. Then, look at data bit number 7 (from the right), which is underlined in the graphic:

```

D NORMAL OPERATI
PI 8 20: 10110000
    
```

This digit represents the computer's interpretation of the PHE signal. If the digit is 1, the computer thinks that the PHE signal is *ON*. If the digit is 0 (as shown above), the computer thinks that the PHE signal is *OFF*.

This information can be used to find the source of the problem. The diagnostic display will show that the PHE input is *ON* when an obstruction is present which should interrupt the photo eye beam. If this is the case, checking the voltage present on the PHE terminal will show if the problem is inside or outside the controller.



**Table 5.4** *Alphabetized Flags/Variables and Their Locations*

FLAG	Definition	Add	Position	FLAG	Definition	Add	Position
ALV	Other car alive output	31	5	FRS	Fire phase 1 input	24	5
API	Alternate Parking Input	33	8	FRSS	Fire phase 1 flag	2D	3
AUTO	Emergency power auto output	31	3	FWI	Fire warning indicator output	25	2
BFD	Bottom floor demand flag	2E	5	GED	Gong enable down output	20	1
CC	Car call flag	21	5	GEDR	Gong enable down output (rear)	10	1
CCA	Car call above flag	2A	1	GEU	Gong enable up output	20	2
CCB	Car call below flag	2A	5	GEUR	Gong enable up output (rear)	10	2
CCC	Car call cancel input	38	6	GHT	Gong hold timer flag	22	4
CCD	Car call disconnect flag	2C	3	GHTR	Gong hold timer flag (rear)	12	4
CCH	Car call hold	26	5	GTDE	Gong timer down enable	26	2
CCR	Car call flag (rear)	11	5	GTUE	Gong timer up enable	26	1
CCT	Car call time flag	22	2	H	High speed output	2B	4
CCTR	Car call time flag (rear)	12	2	HCDX	Hall call disconnect flag	2C	4
CD	Car done flag	2F	4	HCR	Hall call reject flag	2C	5
CNFG	Configuration error flag	38	5	HCT	Hall call door time flag	22	3
CSB	Car stop switch bypass	23	5	HCTR	Hall call door time flag (rear)	12	3
CSBR	Car stop switch bypass (rear)	13	5	HD	High speed delay flag	27	8

**Table 5.4 Alphabetized Flags/Variables and Their Locations**

FLAG	Definition	Add	Position	FLAG	Definition	Add	Position
CTL	Car to lobby input	31	6	HLI	Heavy load input	25	5
CTLDOT	Car to lobby door open timer	31	8	HLW	Heavy load weigher flag	38	1
CTLF	Car to lobby function	31	7	HML	Home landing input	38	8
CTST	Capture for test input	33	3	HOSP	In car hospital emergency input flag	33	1
DBC	Door close button input	20	4	HOSPH2	Hospital emergency phase 2 flag	33	2
DBCR	Door close button (rear)	10	4	HSEL	Hospital service select flag	2B	3
DC	Down call flag	21	7	HYD1-TR0	Hydro/Traction flag	2F	6
DCA	Down call above flag	2A	3	IN	Inspection or access input	27	4
DCB	Down call below flag	2A	7	INCF	Ind. service car call cancel flag	28	3
DCC	Door close complete flag	23	4	IND	Independent service input	27	5
DCCR	Door close complete flag (rear)	13	4	ISR	In service and ready	28	4
DCF	Door close function output	22	8	ISRT	In service truly flag	2C	1
DCFR	Door close function output (rear)	12	8	ISV	In service flag	2C	2
DCLC	Door close contact input	23	6	LD	Level down input	29	7
DCLCR	Door close contact input (rear)	13	6	LFP	Lower parking floor flag	26	8
DCP	Door close power output	22	7	LLI	Light load input	28	1
DCPR	Door close power output (rear)	12	7	LLW	Light load weighing funct. input flag	28	8
DCR	Down call flag (rear)	11	7	LOT	Lobby door time	22	5
DHENDR	Door hold end rear	33	5	LOTR	Lobby door time (rear)	12	5
DDF	Double ding function flag	28	6	LU	Level up input	29	3
DDP	Down direction preference flag	29	5	LWCE	Load weighing change enable flag	38	2
DEADZ	Dead zone flag	30	4	MLT	Motor limit timer flag	2B	7
DHEND	Door hold end	33	4	MLTDO	Motor limit timer door open	27	1
DHLD	Door hold input flag	27	6	MLTP	Motor limit timer pilot flag	27	2
DHLDI	Normal door hold input flag	30	3	NDGBPS	Nudging bypass flag	23	2
DHO	Door hold open flag	21	2	NDGBPSR	Nudging bypass flag (rear)	13	2
DHOR	Door hold open flag (rear)	11	2	NDGF	Nudging function flag	30	1
DIN	Door open inactive	26	4	NDS	Hall door timer non-shorten	21	4
DLI	Dispatch Load Input	38	4	NDSR	Hall door timer non-shorten (rear)	11	4
DLK	Door lock input	28	7	NUDG	Nudging output	23	3
DLKS	Door lock store bit	27	3	NUDGR	Nudging output (rear)	13	3
DLW	Dispatch load weighing function	38	3	NYDS	New York door shortening flag	26	6
DMD	Demand down flag	2A	8	PFG	Passing floor gong output	2F	1
DMU	Demand up flag	2A	4	PH1	Phase 1 return complete flag	30	2
DNDO	Down direction output	29	8	PHE	Photo eye input	20	7
DNS	Down direction sense input	24	4	PHER	Photo eye input (rear)	10	7
DOB	Door open button input	20	3	PIC	PI correction flag	25	1
DOBR	Door open button input (rear)	10	3	R2	Absolute floor encoding #2	30	7
DOC	Door open command	23	8	R3	Absolute floor encoding #3	30	6
DOCR	Door open command (rear)	13	8	R4	Absolute floor encoding #4	30	8
DOF	Door open function output	22	6	REAR	Rear door flag	28	2
DOFR	Door open function output (rear)	12	6	RUN	Run flag	2B	1
DOI	Door open intent flag	21	1	SAB	Sabbath input	33	7
DOIR	Door open intent flag (rear)	11	1	SAF	Safety string input	2C	6

**Table 5.4 Alphabetized Flags/Variables and Their Locations**

FLAG	Definition	Add	Position	FLAG	Definition	Add	Position
DOL	Door open limit input	20	5	SCE	Stepping correction enable	25	8
DOLM	Door open limit memory flag	20	8	SD	Supervisory down flag	2E	8
DOLMR	Door open limit memory flag (rear)	10	8	SDA	Down direction arrow	2E	7
DOLR	Door open limit (rear)	10	5	SDT	Short door time flag	22	1
DPD	Down previous direction	29	6	SDTR	Short door time flag (rear)	12	1
DPR	Door protection timer flag	26	3	SE	Safety edge input	23	7
DSD	Down slow down input	2E	6	SER	Safety edge input (rear)	13	7
DSH	Door shortening flag	2B	2	SLV	Stable slave flag	38	7
DSHT	Door shortening flag	23	1	SST	Soft stop timer flag	2B	5
DSHTR	Door shortening flag (rear)	13	1	STC	Stepping complete flag	2C	7
DZ	Door zone input	20	6	STD/R0	Step down input/absolute floor encoding #0	24	2
DZORDZ	Front or rear door zone input	2D	6	STU/R1	Step up input/absolute floor encoding #1	24	1
DZP	Door zone previous	2C	8	SU	Supervisory up flag	2E	4
DZR	Door zone input (rear)	10	6	SUA	Up direction arrow	2E	3
ECC	Excess car calls flag	2F	5	TEMPB	Temporary bit	2D	8
ECRN	Emergency car run flag	2F	3	TEST	Test switch input	33	6
EPI	Emergency power input flag	31	1	TFA	Timing function active	21	8
EPR	Emergency power return	2F	2	TFAR	Timing function active (rear)	11	8
EPRUN	Emergency power run input	31	2	TFD	Top floor demand flag	2E	1
EPSTP	Emergency power stop input	31	4	TOS	Timed out of service flag	2B	8
EXMLT	External Motor Limit Timer	25	3	UC	Up call flag	21	6
FCCC	Fire phase II car call cancel	25	7	UCA	Up call above flag	2A	2
FCHLD	Fire phase II hold	25	6	UCB	Up call below flag	2A	6
FCOFF	Fire phase II off	27	7	UCR	Up call flag (rear)	11	6
FCS	Fire phase II input	24	6	UDP	Up direction preference	29	1
FCSM	Fire service phase II input memory	2D	5	UFP	Upper parking floor flag	26	7
FDC	Door fully closed phase II	21	3	UFQ	Up first qualifier flag	2D	7
FDCR	Door fully closed phase II (rear)	11	3	UPD	Up previous direction	29	2
FRA	Alt. Fire service phase I input	24	7	UPDO	Up direction output	29	4
FRAS	Alternate fire flag	2D	2	UPS	Up direction sense input	24	3
FRBYP	Fire phase I bypass input flag	2F	8	USD	Up slow down input	2E	2
FRC	Fire phase II flag	2D	1	VCA	Viscosity active	25	4
FREE	No demand and in service	30	5	VCI	Viscosity Input	24	8
FRM	Fire service phase I flag	2D	4	VLT	Valve limit timer	2B	6
FRON	Fire phase I on input flag	2F	7				

## Troubleshooting Specific Problems

This section will describe how to solve some specific problems by using the computer panel.

**Problem: BOTTOM FLOOR OR TOP FLOOR DEMAND message.** The BOTTOM FLOOR OR TOP FLOOR DEMAND message is scrolling on the top line of the LCD display. The Status and Error Messages list (page 6-4), indicates that the message means that there is either a Bottom Floor Demand or a Top Floor Demand. The controller is trying to establish the position of the car by sending it to either the bottom or top floor.



### Note

If the controller has the Absolute Floor Encoding feature, then the controller can establish the position of the car as soon as the car reaches any door zone. The car does not have to travel to a terminal landing to establish the position of the car.

It is normal for the BOTTOM FLOOR OR TOP FLOOR DEMAND message to appear on the display right after power up, after the car is taken off Inspection, or after the RST B computer reset button is pressed. However, in all of these cases, the message should be cleared quickly and then it should not be seen again as the car runs on Normal service.

If the BOTTOM FLOOR OR TOP FLOOR DEMAND message is scrolling for no apparent reason, take the following steps:

The first step in troubleshooting is to decide which of the following scenarios applies:

**Scenario A:** The car is stuck at the bottom floor with the BOTTOM FLOOR OR TOP FLOOR DEMAND error message scrolling constantly.

**Scenario B:** The car runs normally until it reaches the top floor, then the BOTTOM FLOOR OR TOP FLOOR DEMAND error message scrolls and the car goes to the bottom floor. When it reaches the bottom, the message is cleared and the car functions normally until it again reaches the top floor.

**Scenario C:** The car runs normally until it reaches the bottom floor. Then the BOTTOM FLOOR OR TOP FLOOR DEMAND error message scrolls and the car goes to the top. After it gets there, the message is cleared and the car runs normally until it again reaches the bottom floor.

**What to do for Scenario A:** A Bottom Floor Demand should be cleared when all of the following conditions are met:

1. The car is at the bottom and the Down Slow Down (DSD) input to the controller is *OFF*.
2. The Door Zone (DZ) input to the controller is *ON*.
3. The Door Lock (DLK) input to the controller is *ON*.
4. The leveling signals ULM(LU), DLM(LD) are *OFF*.

Look up the DSD, DZ, ULM(LU), DLM(LD) and DLK signals in the computer memory (see “Troubleshooting Using the Computer's Internal Memory” on page 5-9). When the car is at the bottom floor with the doors locked, the correct values for these signals in the computer memory are as follows:

DSD= 0 (OFF)  
 DZ= 1 (ON)  
 ULM(LU) = 0 (OFF)  
 DLM(LD) = 0 (OFF)  
 DLK = 1 (ON)

If there is a different value for any of the 3 signals, check the wiring associated with that particular signal.

For example, if the DSD signal is equal to 1 (ON) in the computer memory, inspect the DSD input wiring, including the Down Slow Down limit switch. The Down Slow Down switch contacts should be open when the car is at the bottom.

**What to do for Scenario B:** In this situation, the USD input is usually the problem. Look at the USD signal in the computer memory (Address 2E, Position 2). USD should be *ON* except when the car is at the top; then it should be *OFF*. If the signal is not following this rule, then inspect the wiring associated with the USD input, including the Up Slow Down limit switch. The Up Slow Down switch contacts should be open when the car is at the top.

**What to do for Scenario C:** In this situation, the DSD input is usually the problem. Look at the DSD signal in the computer memory (Address 2E, Position 6). DSD should be *ON* except when the car is at the bottom; then it should be *OFF*. If the signal is not following this rule, then inspect the wiring associated with the DSD input, including the Down Slow Down limit switch. The Down Slow Down switch contacts should be open when the car is at the bottom.

## Setting Parameters (Options) to Default Values

There are occasions when it is necessary to set the parameters (options) to their default values. Setting the parameters to their default values is usually required when:

- The MC-MPU software is changed.
- RAM memory becomes corrupted. This sometimes happens due to lightning.

### To set the MC-MPU parameters to their default values:

1. Place the car on Machine Room Inspection.
2. Place function switches **F1**, **F3**, **F5** and **F7** in the **On** (up) position.
3. Press all four push buttons (**N**, **S**, **+**, **-**) at the same time.
4. Using the settings shown in Appendix A, *Original Programmed Values and the Record of Changes*, reprogram the values that are different from the default values.

## F1: Program Mode

This section will explain how to use Program mode. Enter Program mode by moving the **F1** switch on the computer board to the up position. Program mode can be used to program the controller to meet the requirements of the elevator such as, the selection of stops and fire floors, or changing timer values and selecting options such as nudging. The Motion 2000 controller has already been programmed at MCE. Usually, the controller does not have to be programmed during the initial installation. Program mode can be used later to modify the elevator operation.

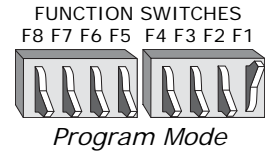

Refer to the Programming Record in the Job Prints for a list of the options and values programmed into the controller at MCE. If you choose, you may copy these values into the space provided in Appendix A.



Note

If any changes are made using Program mode, record them in writing for future reference (use Appendix A).

## General Description of Program Mode

The car must be on Inspection before Program mode can be used. Messages will appear on the LCD display. Use the **N** and **S** push buttons to find and select options and to change values. The next several subsections describe in detail how to use Program mode.

### Viewing Menus on the LCD Display

All of the programmable options and features are divided into menus. The following is a list of the menus:

- |                     |                     |                             |
|---------------------|---------------------|-----------------------------|
| Basic Features Menu | Timer Menu          | Spare Outputs Menu          |
| Fire Service Menu   | Gongs/Lanterns Menu | Extra Features Menu         |
| Door Operation Menu | Spare Inputs Menu   | Additional Car Options Menu |

For each menu, there is a Menu Message on the display. To look at these Menu Messages, enter Program mode by moving the **F1** switch to the up position. The Start Message will appear:

```
PROGRAM MODE
PRESS N TO BEGIN
```

Press the **N** push button, and release it. The first Menu Message will appear:

```
*BASIC FEATURES*
MENU
```

Press the **N** push button again the next Menu message will appear:

```
* FIRE SERVICE *
```

Hold down the **N** push button, each Menu Message will appear, one at a time. Finally, the Start Message will appear again.



### Viewing Options Within a Menu

The options can be viewed inside a particular menu by pressing the **S** push button when the Menu Message appears on the display. For example, to look at the options in the Door Operation Menu, first press the **N** push button until the Door Operation Menu Message appears:

```
*DOOR OPERATION*
      MENU
```

Press the **S** push button. The following display will appear:

```
NUDGING? YES
```

To view the next option, press the **N** push button. Hold down the **N** push button to scroll through the options. Eventually the Menu Message will reappear, or to return directly to the Menu Message while the options are displayed, press the **N** and '+' push buttons at the same time. Press the **S** push button to see the options for that same menu again, or press the **N** push button to go on to the next menu.

### Changing a Value

For each option that appears, the value can be changed by pressing the **S** push button. While in the Timer, Spare Inputs and Spare Outputs menus, pressing and holding the **S** push button for five seconds causes the display to scroll through the values at a faster rate. Also, in those same menus, pressing the **S** and '-' push buttons at the same time will cause the display to scroll backwards and pressing the **S** and '+' push buttons at the same time will reset the option to NOT USED. To return directly to the Menu Message while the values or options are displayed, press the **N** and '+' push buttons at the same time.

Going back to the previous example in which the Nudging option was on the display:

```
NUDGING? YES
```

Pressing the **S** push button to changes Nudging to NO:

```
NUDGING? NO
```

### Saving the New Values

Whenever options or values are changed in Program mode, this information must be saved in the computer's memory. When the changes are complete, press the **N** push button until the following message appears:

```
*SAVE CHANGES?*
* N=NO S=YES *
```

Press the **S** push button to save the changes. The Start Message will appear again. When programming is complete, move the **F1** switch back to the down position.

 **Note**

If the values have not been saved, they will be lost when **F1** is switched back to **OFF** (down) position. *Make sure* to keep an account of saved changes on the record provided in Appendix A.

### Restoring Original Values

When using Program mode, if some values have been changed, but then you decide to go back to the old values, exit Program mode without saving the changes. Move the **F1** switch back to the down position and the original values will be restored.



### Step-by-Step Example

The table provides a step-by-step example of using Program mode. In this example, the Fire Phase I Alternate floor will be changed. Similar steps can be taken to change any option.

**Table 5.5 Using the Program Mode**

Steps to take	Display menus and sub-menus	
Put the car on Inspection	D INSPECTION OPE PI 8 20:10110000	
Flip <b>F1</b> switch Up	PROGRAM MODE PRESS N TO BEGIN	
Press <b>N</b> button for Next	*BASIC FEATURES* * MENU *	
Press <b>N</b> button for Next	* FIRE SERVICE * * MENU *	
Press <b>S</b> button to Select		FIRE SERVICE OPERATION? YES
Press <b>N</b> button for Next		FIRE PHASE I MAIN FLOOR = 1
Press <b>N</b> button for Next		FIRE PHASE I ALT. FLOOR = 1
Press <b>S</b> button to select next available value. If you pass the desired value, press <b>S</b> until the desired value appears again.		FIRE SVCE. CODE ALT.FLOOR = 3
Press <b>N</b> button for Next		FIRE SVCE. CODE XXXX
Press <b>N</b> button for Next		BYPASS STOP SW. ON PHASE I? YES
Press <b>N</b> button to scroll through any remaining Fire Service sub-menus.		
Press <b>N</b> button for Next	* FIRE SERVICE * * MENU *	
Press <b>N</b> button for Next	*DOOR OPERATION* * MENU *	
Press <b>N</b> button for Next	* TIMER * * MENU *	
Press <b>N</b> button for Next	*GONGS/LANTERNS* * MENU *	
Press <b>N</b> button for Next	* SPARE INPUTS * * MENU *	
Press <b>N</b> button for Next	*SPARE OUTPUTS* * MENU *	
Press <b>N</b> button for Next	*EXTRA FEATURES* * MENU *	
Press <b>N</b> button for Next	*ADDITIONAL CAR* * OPTIONS *	
Press <b>N</b> button for Next	* SAVE CHANGES? * * N=NO S=YES *	
Press <b>S</b> button to Save	PROGRAM MODE PRESS N TO BEGIN	
Flip <b>F1</b> switch Down and take car off of Inspection	<i>The new options are stored and are now in effect.</i>	

## Basic Feature Menu Options

**CONTROLLER TYPE:** (*HYDRO (M2000)/TRACTION (M4000)*) Determines the firmware that will be used for this controller. This parameter should have been factory set based on the type of controller in use, hydro or traction.

**SIMPLEX / LOCAL OR DUPLEX?** The controller has been programmed at the factory for either simplex, local or duplex capability.

If the controller has simplex capability, it can only operate a single car as a simplex.

This parameter should be set to LOCAL if the car is part of a group connected to a group dispatcher.

If the controller has duplex capability, then it can operate a single car as a simplex, or it can be connected to a second Motion 2000 controller and the 2 controllers can operate 2 cars as a duplex.

Both Motion 2000 controllers must have duplex capability for this arrangement to work. Also, the Simplex/Duplex option on each controller must be set to duplex.

In Duplex configuration, one of the controllers will assert itself as the dispatcher and will remain the dispatcher unless it is taken offline. The dispatching controller will show a “D” on its LCD; the other, an “S.” Hall calls are physically connected to both controllers

**OPERATION:** Dispatching operation - For simplex operation, there are 3 dispatching operations to choose from: Selective Collective, Single Button Collective, or Single Automatic Push button. Each operation is described below:

- **Selective Collective** - Choose this operation if there is an UP and DOWN button at each landing station except for the top floor (DOWN button only) and bottom floor (UP button only) and any number of calls can be registered at one time.
- **Single Button Collective** - Choose this operation if there is only 1 call button at each landing station and any number of calls can be registered at one time.
- **Single Automatic Push button** - Choose this operation if there is only 1 call button at each landing station and only 1 call can be registered and/or serviced at a time.

### Note

If either Single Button Collective or Single Automatic Push button operation is selected, then one of the spare output terminals should be used for an INDFRC output. This output is used to disconnect the hall calls during Fire Service and Independent Service (see “Spare Outputs Menu Options” on page 5-39, INDFRC output for more details). Refer to the Job Prints for information on using the INDFRC output to disconnect hall calls.

For duplex operation, the dispatching scheme is always Selective Collective. Therefore, the Operation option message will not appear on the display if the duplex option has been selected.

**Caution**

The following BASIC FEATURE MENU OPTIONS affect the terminal assignments on the HC-UIO boards used for call related I/O (boards numbered 00 thru 31). Please refer to “HC-UIO Board Call Assignments” on page 6-59. It is recommended that the terminal connectors be unplugged from these HC-UIO boards when making changes to these settings. If parameters/terminal assignments are changed, the associated controller wiring must also be changed.

**TOP LANDING SERVED? (simplex)/TOP LANDING FOR THIS CAR? (duplex)** Set this option to the highest floor served by this car. This parameter determines the number of HC-UIO board terminals assigned for PIs, unless the “DISCRETE PI'S ON UIO” option is set to NO (see page 5-19).

**HC-RDR BOARD ON THIS CAR?** YES/NO - Set to Yes if this car has a second set of doors controlled by an HC-RDR board.

**CAR SERVES FRNT/FLR 1? (simplex)/THIS CAR SERVES FRNT/FLR 1? (duplex)** YES/NO - Setting this option to YES indicates that this car is eligible to serve a front opening at this floor. This option will continue to be asked until the top landing is reached. Press the '+' push button to scroll through the available landings. Press the S push button to select Yes/No. Press the N push button for the next option. This parameter determines the number of HC-UIO board terminals assigned for front car calls, unless the “SERIAL COP BOARD HC-CPI?” option is set to YES (see page 5-19).

**CAR SERVES REAR/FLR 1? (simplex) / THIS CAR SERVES REAR/FLR 1? (duplex)** YES/NO - Setting this option to YES indicates that this car is eligible to serve a rear opening at this floor. This option inquiry will continue until the top landing is reached. Press the '+' push button to scroll through the available landings. Press the S push button to select Yes/No. Press the N push button for the next option. This parameter determines the number of HC-IUO board terminals assigned for rear car calls, unless the “SERIAL COP BOARD HC-CPI?” option is set to YES (see page 5-19).

**TOP LANDING FOR OTHER CAR? (duplex)** Set this option to the highest floor served by the other car. This parameter determines the number of HC-UIO board terminals assigned for PIs, unless the “NO DISCRETE PI'S ON UIO” option is set to YES.

**HC-RDR BOARD ON OTHER CAR? (duplex)** YES/NO - Set to Yes if the other car of a duplex has a second set of doors controlled by an HC-RDR board.

**OTHER CAR SERVES FRNT/FLR 1? (duplex)** YES/NO - Setting this option to YES indicates that the other car of a duplex is eligible to serve a front opening at this floor. This option will continue to be asked until the top landing is reached.

**OTHER CAR SERVES REAR/FLR 1? (duplex)** YES/NO - Setting this option to YES indicates that the other car of a duplex is eligible to serve a rear opening at this floor. This option will continue to be asked until the top landing is reached.

**Note:** *Both* controllers in a duplex must be programmed with this information. These option inquiries must be answered for both cars.

**PARKING FLOOR** Any landing can be selected to be the parking floor. The car will go to the parking floor when it is free of call demand. In addition, there is a Parking Delay Timer that will cause a free car to wait for a short time before parking. The timer is adjustable, with a value between 0.0 minutes (no delay) and 6.0 minutes (see [“PARKING DELAY TIMER”](#) on page 5-27). If the parking feature is not needed, choose NONE when the Parking Floor option message is on the display. The car will stay at the last call answered.

**ALT. PARKING FLOOR** This option is available only when the API input is programmed and a parking floor is set. Any landing can be selected to be the alternate parking floor. This car will go to the alternate parking floor when it is free of call demand and the API input is active.

**SECONDARY PARKING FLOOR** This option is for duplex systems only. Any landing can be selected to be the secondary parking floor. The car will go to this floor when it becomes free of call demand and the other car is already parked at the first parking floor. It is acceptable to make the secondary parking floor the same as the first parking floor, if both cars are to park at the same floor. If a second parking floor is not needed, choose *NONE* when the Secondary Park Floor option message is on the display. Then, the first free car will go to the first parking floor, but the second car will stay at the last call answered.

**LOBBY FLOOR** Any landing can be selected to be the Lobby Floor. When the car answers either a hall or car call at this floor, the doors will stay open until the Lobby Door Timer elapses (the Lobby Door Timer is adjustable, see [“LOBBY DOOR TIMER”](#) on page 5-26). NOTE: The Lobby Floor is also used for CTL input.

**CAR IDENTIFIER** This option is for duplex systems only. Its purpose is to specify which controller is assigned to car A and which controller is assigned to car B. This is primarily used for controllers that use a peripheral device such as a CRT.

**SERIAL COP BOARD HC-CPI?** *YES/NO* - Yes indicates that the COP signals are being handled by an HC-CPI Serial COP board and therefore the car calls should not be assigned to HC-UIO board terminals.

**DISCRETE PI's on UIO?** Set to No if the car uses serial (CE) position indicator fixtures. See caution above.

- Set to Yes if PI's are connected to HC-UIO boards.

**DEDICATED PI BOARD?** (Appears if “Discrete PI's on UIO?” is set to Yes. Dedicates the first one or two HC-UIO boards to PI's alone [no call connections]).

- If Yes: Position Indicators will be located on UIO Board 0 (zero) for 2 - 16 stops or boards 0 (zero) and 1 (one) for 2 - 32 stops (board 1 handles 17 - 32 [assuming that PI is one wire per floor]). Calls will begin on a new UIO Board immediately following Board 0 or 1.
- If No: PI's are located on UIO boards but calls can begin immediately following the last PI rather than on the next UIO board.

**SERIAL CARTOP DOOR CNTRL?** *YES/NO* - Yes indicates that door control is being handled by an HC-UIO board that is installed on the car top.

**DISABLE LOCAL HALL CALLS?** Set to Yes if the car is dispatched by a group controller and should not respond to a local (connected to car) riser. If this car has swing operation, do not set this to Yes as it will prevent the car from responding to local riser calls.

## Fire Service Menu Options

**FIRE SERVICE OPERATION?** If Fire Service operation is not required, then this option should be set to *NO*. Otherwise, if set to *YES*, the options below will appear on the LCD display.

**FIRE PHASE 1 MAIN FLOOR** Any landing can be selected to be the Main Fire Return Floor for Fire Service.

**FIRE PHASE 1 ALT. FLOOR** Any landing can be selected to be the Alternate Fire Return Floor for Fire Service.

**FIRE SVCE. CODE** The Fire Service Operation will conform to the selected fire service code. The fourteen different codes to choose from are:

- |   |                        |
|---|------------------------|
| 1. CHICAGO (OLD)                        | 9. CITY OF HOUSTON     |
| 2. VET ADMIN (Veterans' Administration) | 10. AUSTRALIA          |
| 3. NYC RS-18                            | 11. CITY OF DETROIT    |
| 4. ANSI A17.1 -89>                      | 12. MASSACHUSETTS      |
| 5. CALIF. TITLE 8                       | 13. ANSI A17.1 85 - 88 |
| 6. HAWAII                               | 14. CITY OF DENVER     |
| 7. CSA B44-M90                          | 15. CHICAGO 2001       |
| 8. 34 PA CODE, CH. 7                    | 16. ANSI A17.1-2000    |

**FIRE PHASE I 2ND ALT. FLOOR** Detroit Fire Code only. Any landing may be the 2<sup>nd</sup> alternate fire return floor. Select None if there is no second alternate return floor.

**WILL THIS CAR RUN ON PH2?** This car is allowed to run on Fire Phase II if this option is set to *YES*.

**BYPASS STOP SW. ON PHASE 1?** This option was added to keep the stop switch from being bypassed on Fire Phase I. With this option set to *NO*, the CSB output will not come *ON* as the car is returning on Fire Phase I.

**HONEYWELL FIRE OPERATION?** This option is only available if the FIRE SVCE. CODE option is set to AUSTRALIA (see [“FIRE SVCE. CODE” on page 5-20](#)). If this option is set to *YES* then the Australia fire code will conform to Honeywell’s requirements. If this option is set to *NO* then the controller will conform to standard Australia code.

**NYC FIRE PHASE 2 AND ANSI 89?** This option is only available if the FIRE SVCE. CODE option is set to ANSI A17.1 89 (see [“FIRE SVCE. CODE” on page 5-20](#)). If this option is set to *YES* then the ANSI A17.1 89 Fire Code will conform to New York City Fire Code requirements when on Fire Phase 2. If this option is set to *NO* then the controller will conform to standard ANSI A17.1 89 Fire Code.

**WHITE PLAINS, NY FIRE CODE?** This option is only available if the FIRE SVCE. CODE option is set to ANSI 17.1 89 (see [“FIRE SVCE. CODE” on page 5-20](#)). The city of White Plains requires that if fire phase one is still in effect, the car can exit fire phase two regardless of the position of the doors. Setting this option to *YES* will comply with this requirement.

**MASS 524 CMR FIRE CODE?** This option is only available if the “FIRE SVCE. CODE” option is set to “A17.1 - 2000”. If this option is set to YES, the ASME A17.1-2000 fire code will conform to the Massachusetts 524 CMR requirements. If this option is set to *NO*, the controller will conform to the standard ASME A17.1-**2000 code**.

**ASME A17.1A 2000 ADDENDA?** Set to the appropriate addenda for your jurisdiction. (2005, 2007, NONE)

**DISABLE DPM ON FIRE PH.2?** If Yes, Door Position Monitoring is disabled when the car is on In-Car Firefighter operation (Fire Phase 2). If No, DPM is not disabled on Fire Phase 2.

**LOW VOLTAGE FIRE SENSORS?** If the fire sensors on this job use 24V signal levels, set this option to Yes. If set to No, the signal level is assumed to be 120 VAC.

**LATCH FLASHING FIRE HAT?** If a fire/smoke sensor in the elevator machine room or hoistway<sup>1</sup> initiates an alarm, the fire hat indicator will flash. A flashing indicator may be reset in one of two ways:

- If this option is set to Yes: Fire service must be reset using the fire service key switch before the indicator will cease flashing. Resetting an individual initiating alarm will not stop the indicator from flashing.
- If this option is set to No: The indicator will stop flashing once the initiating alarm is reset.

---

1. A17.1/B44 code edition/addenda or jurisdiction dependent: (A) for ASME A17.1-2004/CSA B44-04 and later, the machine room or hoistway sensor must be the sensor that initiated Fire Phase I for the hat to flash; or (B) for earlier editions of A17.1/B44, the fire hat will flash any time the machine room or hoistway sensor is active, regardless of which device initiated Fire Phase I. Also, some jurisdictions occasionally modify the A17.1/B44 requirements, so please consult with the jurisdictional authorities for additional requirements.

## Door Operation Menu Options

**NUDGING?** Enables Nudging Operation when doors are prevented from closing. During Nudging Operation, controller will turn ON the NUDG output to signal the door operator to close the doors at reduced speed. The NUDG output will stay ON for the amount of time the Nudging Timer specifies and then cycle off for the same amount of time. This cycle will continue until the doors have fully closed.

The NUDG output can also be used to activate a buzzer. The PHE (Photo Eye) input will be ignored during nudging if the Stuck Photo Eye Protection option has been selected (see [“STUCK PHOTO EYE PROTECTION?” on page 5-22](#)). A Safety Edge or Door Open Button input will stop the doors from closing, but will not reopen the doors fully. Nudging Operation will begin when the Nudging Timer elapses. The Nudging Timer starts when the regular door timer elapses. The Nudging Timer is adjustable (see [“NUDGING TIMER \(Range: 10-240 Seconds\)” on page 5-26](#)).

**STUCK PHOTO EYE PROTECTION?** When enabled, causes controller to ignore PHE (Photo Eye) input and close the doors after the Nudging Timer elapses if the Nudging option is selected or when the Time Out of Service Timer elapses, whichever comes first. If the Nudging option is not selected, the PHE input will be ignored when the Time Out of Service Timer elapses. (see [“TIME OUT OF SERVICE TIMER \(Range: 15-240 Seconds, or None\)” on page 5-26](#) for more details.)

If the Stuck Photo Eye Protection option is not selected, a PHE input that is stuck ON will keep the doors open indefinitely..

**SEQUENTIAL DOOR OPER. (F/R)?** This option is available only if independent rear doors are present. If this option is set to *YES* then the front and rear doors of the car do not open at the same time. Whenever the controller receives a front and rear call to the same landing, the car will, upon reaching that landing, first open the front doors and close them, then open the rear doors and close them. The default is to open the front doors first unless the rear doors have already started to open.

**CAR CALL CANCELS DOOR TIME?** If this option is selected, pressing a car call button when the doors are fully open will cause the doors to start closing. There is one exception. If the car is stopped at a floor, pressing the car call button *for that same floor* will not cause the doors to close, but will cause the doors to reopen if they are in the process of closing.

**NUDGING DURING FIRE PH. 1?** If selected, the controller will turn ON the NUDG output while the doors are closing during Fire Phase 1. The NUDG output signals the door operator to close the doors at reduced speed. This is useful for elevators that do not have mechanical safety edges. During Fire Phase 1, all smoke sensitive reopening devices must be disabled. This includes photo eyes and other devices that use infrared beams. If there are no other reopening devices active, the doors should close at reduced speed..

**RETIRING CAM OPTION?** This option should be selected for elevators with retiring cams. This option affects the car only when it is sitting at a floor. Without this option, the controller will wait until the doors are closed and locked before it turns *OFF* the door close signal. However, if the elevator has a retiring cam, the doors will not be locked until the retiring cam is activated.



If this option is selected, the controller will turn *OFF* the door close signal when the doors are *closed* instead of waiting for the doors to be locked. More precisely, the controller will turn *OFF* the door close output signal (DCF) when the DCLC (Doors Closed Contact) input is *ON* or when the DCL (Door Close Limit) input is *OFF*, instead of waiting for the DLK (Door Lock) input to turn *ON*.

**PRE-OPENING?** If this option is selected, the controller will begin to open the doors just before the car completely stops at a floor. More precisely, the controller will turn *ON* the DOF (Door Open Function) output signal when the DZ (Door Zone) input turns *ON*. Typically, the DZ input first turns *ON* when the car is about 3 inches away from the final stopping point. This option is not recommended for elevators that may spend an extended period of time in leveling.

**MECHANICAL SAFETY EDGE?** If this option is selected, the Nudging Operation will cycle until the doors are fully closed. Otherwise, the nudging function will operate continuously to comply with code requirements where a door reopening device is not used (see “[NUDGING?](#)” on page 5-22 for more details).

**NUDGING OUTPUT/BUZZER ONLY?** If selected with the Nudging option, NUDG output will be activated when Nudging Timer elapses. However, if either the Mechanical Safety Edge or the Door Open button is activated, the doors will stop and reopen fully. If this option is not selected, the doors will simply stop under these circumstances, but will not reopen fully. This option may be useful when only a nudging buzzer is required but actual Nudging Operation is not needed (see “[NUDGING?](#)” on page 5-22 for more details). With this option and the NUDGING option both set to YES, DOOR CLOSE PROTECTION TIMER ELAPSED faults are not generated.

**D.C.B. CANCELS DOOR TIME?** When the doors are fully open, this option will cancel any pre-existing door time and cause the doors to start closing when the Door Closed button is pressed.

**LEAVE DOORS OPEN ON PTI/ESS?** This option is displayed when either the PTI or ESS spare inputs have been programmed. With this option set and either the Power Transfer (PTI) input or the Elevator Shutdown Switch (ESS) input selected and active, once the car has stopped at a floor, the doors will remain open instead of cycling closed.

**NUDGING DURING FIRE PHASE 2?** If this option is selected, the controller will turn *ON* the NUDG output while the doors are closing during Fire Service Phase II. The NUDG output signals the door operator to close the doors at reduced speed.

**DIR. PREFERENCE UNTIL DLK?** This option causes the car to maintain its present direction preference until the doors are fully closed. Otherwise, the direction preference is maintained only until the door dwell time expires.

**FULLY MANUAL DOORS?** Set this option to *YES* when the doors are opened and closed manually versus automatically.

**CONT. D.C.B. TO CLOSE DOORS?** When this option is set to *YES*, the doors will remain open while the car is at a landing until the Door Close button is pressed. While the Door Close button is pressed, the doors will continue to close. If the Door Close button is released before the doors have closed fully, the door will re-open.

**CONT. D.C.B. FOR FIRE PH 1?** When set to *YES*, the doors will remain open when the car goes on Fire Service Phase I until constant DCB forces them closed.

**MOMENT. D.O.B. DOOR OPENING?** This option is used to require the momentary pressure on the Door Open Button (DOB) to open the doors. If set to *NO*, momentary pressure on the DOB is not required to open the doors when the car reaches a landing. The doors open automatically in response to a call.

**MOMENT D.O.B. FOR: (FRONT CALLS/ REAR CALLS/ BOTH CALLS)** - Choose whether front calls, rear calls or both calls need momentary D.O.B.

- *FRONT CALLS* - this option necessitates that DOB be pressed when the car responds to *front* door calls. Rear door calls are not affected.
- *REAR CALLS* - this option necessitates that DOB be pressed when the car responds to *rear* door calls. Front door calls are not affected.
- *BOTH CALLS* - this option necessitates that DOB be pressed when the car responds both *front* and *rear* door calls.

**MOMENT D.O.B. FOR: (HALL CALLS/ CAR CALLS/ ALL CALLS)** - Choose whether hall calls, car calls or all calls need momentary D.O.B.

- *HALL CALLS* - this option necessitates that DOB be pressed when the car responds to *hall calls*. Car calls are not affected.
- *CAR CALLS* - this option necessitates that DOB be pressed when the car responds to *car calls*. Hall calls are not affected.
- *ALL CALLS* - this option necessitates that DOB be pressed when the car responds to both *hall calls* and *car calls*.

**DOORS TO OPEN IF PARKED:** (*NONE/FRONT/REAR/BOTH*) - If set to *NONE*, the doors remain closed while the car is parked. When set to *FRONT*, *REAR*, or *BOTH*, the corresponding doors automatically open and remain open while the car is parked. This option is available only if a parking floor is programmed in the Basic Features menu. *BOTH* option is not available if the car is programmed for sequential door operation (see “[SEQUENTIAL DOOR OPER. \(F/R\)?](#)” on page 5-22 for more details.

**DOORS TO OPEN ON MAIN FIRE?** The choices for this option are *FRONT*, *REAR* and *BOTH*. This option determines which door(s) should open once the car has completed a Main Fire return (only if the *CAR ARE WALK-THRU?* option is set to *YES*).

**DOORS TO OPEN ON ALT FIRE?** The choices for this option are *FRONT*, *REAR* and *BOTH*. This option determines which door(s) should open once the car has completed an Alternate Fire return (only if the *CAR ARE WALK-THRU?* option is set to *YES*).

**LEAVE DOORS OPEN ON CTL?** This option is displayed when the CTL spare input is programmed. When set to *YES*, and the CTL (car to lobby) input is active, once the car has returned to the lobby, the doors will remain open instead of cycling closed.

**LIMITED DOOR RE-OPEN OPTION** Once the doors begin to close after a door dwell time has expired, if a re-opening device input (PHE or SE) is seen, this option will allow the doors to re-open as long as the re-opening device is active. Once the re-opening device is inac-

tive, the doors will immediately begin to close again. Without this option set, in this same case, the doors will re-open fully for a short door time and then close.

**REDUCE HCT WITH PHOTO EYE** This option will cause a normal hall call time to be shortened to a short door time if a photo eye input is seen.

**LEAVE DOORS OPEN ON EPI** This option is displayed when the EPI spare input is programmed. When set to *YES*, and EPI (Emergency Power) input is active, once the car returns to the emergency power return floor, the doors are left open instead of cycling closed.

**DOORS TO OPEN IF NO DEMAND:** (*NONE/FRONT/REAR/BOTH*) - When set to *NONE*, the doors remain closed when the car is at a landing with no demand. When set to *FRONT*, *REAR*, or *BOTH*, the corresponding doors automatically open and remain open when the car is at a landing with no demand. *BOTH* option is not available if the car is programmed for sequential door operation (see “[SEQUENTIAL DOOR OPER. \(F/R\)?](#)” on page 5-22).

**CONST. PRESS OP. BYPASS PHE?** This option is used to indicate if Constant Pressure Operations, such as Independent Service, Attendant Service, or if the Constant Pressure Door Close option is set to *YES*, should bypass the Photo Eye when the Photo Eye is active and there is a demand to close the doors and move the car. When set to *YES*, the car will bypass the Photo Eye and nudge the doors closed. When set to *NO*, the car will not bypass the Photo Eye; the doors will remain open until the Photo Eye is cleared.

**DOOR TYPE IS HORIZONTAL / VERTICAL** This option is used to indicate if the doors open horizontally or vertically. When set to vertical, requires constant pressure on the door close button (DCB) to shut the doors when exiting Fire Phase 2 away from the recall floor with Fire Phase 1 active (ASME A17.1 requirement).

**FRONT DOOR MECH. COUPLED?** *YES/NO* - Set to *YES* if the front car gate is mechanically coupled to the hallway doors. To satisfy A17.1-2000 code requirements, this option is used to qualify the various door faults when the Retiring Cam Option (see “[RETIRING CAM OPTION?](#)” on page 5-22) is set to *YES* and this option is set to *YES*.

**REAR DOOR MECH. COUPLED?** *YES/NO* - Set to *YES* if the rear car gate is mechanically coupled to the hallway doors. To satisfy A17.1-2000 code requirements, this option is used to qualify the various door faults when the Retiring Cam Option (see “[RETIRING CAM OPTION?](#)” on page 5-22) is set to *YES* and this option is set to *YES*.

**PREVENT DCP TIL DOORS CLOSE?** This option is displayed when the Retiring Cam Option is set to *YES*. When this option is set to *YES*, the DCP output will not be generated until the doors close and a demand is present. Set this option to *YES* when it is required that the doors be fully closed before asserting DCP, e.g., when DCP is used to power the retiring cam RC relay, DCP should be asserted only after the doors have fully closed as indicated by the DCL input.

**MOMENT. D.C.B TO CLOSE DOORS?** *YES/NO* - When this option is set to “*YES*” a momentary push on the door close button is required to allow the doors to close while on normal operation.

**DOORS TO LATCH DOF?** *FRONT/REAR/BOTH/NONE* - This option would maintain the Door Open Function on the selected doors continuously as long as a door closing command is absent.

**DOORS TO LATCH DCF?** *FRONT/REAR/BOTH/NONE* - This option would maintain the Door Close Function on the selected doors continuously as long as a door opening command is absent.

**INV. DOOR CLOSE LIMIT?** *NONE/FRONT/REAR/BOTH* - Set this option for doors that require inverted door close limit input logic (DCL and/or DCLR). When this option is set, the DCL and/or DCLR inputs must be active when the doors are closed and inactive when the doors are open.

**FIRE PH2. WITH DOORS CLOSED? Yes/No** **FULLY MANUAL DOORS ONLY:** If set to Yes, a car recalled on Fire Phase 1 is allowed to enter Fire Phase 2 with doors closed.

## Timer Menu Options

**SHORT DOOR TIMER** (Range: 0.5-120.0 Seconds) - This is the length of time the doors will stay open after being reopened by the Photo Eye, Safety Edge or Door Open button.

**CAR CALL DOOR TIMER** (Range: 0.5-120.0 Seconds) - This is the length of time the doors will stay open when the car stops to answer a car call.

**HALL CALL DOOR TIMER** (Range: 0.5-120.0 Seconds) - This is the length of time the doors will stay open when the car stops to answer a hall call.

**LOBBY DOOR TIMER** (Range: 0.5-120.0 Seconds) - This is the length of time the doors will stay open when the car stops to answer either a hall call or a car call at the Lobby Floor. The location of the Lobby Floor is programmable (see [“LOBBY FLOOR”](#) on page 5-19).

**NUDGING TIMER (Range: 10-240 Seconds)** Used only if the Nudging option is selected. Door Nudging Operation will begin when Nudging Timer elapses. Nudging Timer will start when regular door timer elapses. This timer also determines the ON and OFF cycle time for the NUDG output. (see [“NUDGING?”](#) on page 5-22)

**TIME OUT OF SERVICE TIMER (Range: 15-240 Seconds, or None)** Used to take a car out of service when it is held at a floor excessively and calls are registered at other floors. Timer starts when a call is registered at another floor. If timer expires before the car closes its doors and begins to move, the car will be placed out of service. Typically, this occurs when doors are held open by continuous activation of photo eye, a call button, or another reopening device. When NONE is selected, no Time Out of Service timing is performed.

When the timer expires, the Timed Out of Service Indicator on the HC-MPU board will turn ON. The controller will ignore the PHE (Photo Eye) input if the Stuck Photo Eye Protection option is selected. In duplex or group installations, hall calls assigned to the car will be assigned to another car. When the car closes its doors and begins to move again, it will return to Normal service.

**MOTOR LIMIT TIMER** (Range: 1.0 - 6.0 Minutes) - This timer starts whenever the controller attempts to move the car in the up direction and is reset when the car reaches its destination floor. If the timer expires before the car reaches its destination, the controller stops trying to move the car up, to protect the motor. The car will then lower to the bottom floor and shut-down. The Motor/Valve Limit Timer Indicator on the HC-MPU board will turn *ON*.

**VALVE LIMIT TIMER** (Range: 1.0 - 6.0 Minutes) - This timer starts whenever the controller attempts to move the car down, and is reset when the car reaches its destination floor. If the timer expires before the car reaches its destination, the controller will stop trying to move the car, in order to protect the valves. The Motor/Valve Limit Timer Indicator on the HC-MPU board will turn *ON*.

**DOOR HOLD INPUT TIMER** (Range: 0-240 Seconds) - This timer will be used only if there is a DHLD (Door Hold) input on the controller (see [“Spare Inputs Menu Options” on page 5-29](#)). Usually, a Door Hold button will be connected to this input. This timer determines the amount of time that the doors will stay open when the door hold open button is pressed. The timer will be canceled and the doors will begin to close, if either the Door Close button or a Car Call button is pressed. If a Door Hold Key switch (instead of a button) is connected to the DHLD input, this timer value should be set to 0, so that the doors will close when the switch is turned to the *OFF* position.

**PARKING DELAY TIMER** (Range: 0.0-6.0 Minutes) - This timer is used only if a parking floor is selected (see [“PARKING FLOOR” on page 5-19](#) and see [“ALT. PARKING FLOOR” on page 5-19](#)). The timer starts when the car is free of call demand. The car will not park until the timer elapses.

**FAN/LIGHT OUTPUT TIMER** (Range: 1.0-10.0 Minutes) - Used with the FLO output. This timer sets the amount of time that will pass before the FLO output will be activated. The time will start when the car becomes inactive. The FLO output should be connected to a relay that when activated, will turn *OFF* the fan and light within the car. This output is also used for *PI Turned Off if No Demand* (see [“PI TURNED OFF IF NO DEMAND?” on page 5-50](#)).

**HOSPITAL EMERG. TIMER** (Range: 1.0-10.0 Minutes) - Used when the HOSPITAL EMERG. OPERATION option is set to YES. This timer sets the amount of time that the car will remain at the hospital emergency floor with the doors open before automatically returning to normal service (see [“HOSPITAL EMERG. OPERATION?” on page 5-50](#)).

**DOOR OPEN PROTECTION TIMER** (Range 8 - 30 Seconds) - This timer determines how long the door operator will attempt to open the doors. If DOL does not go low within this time, the doors will then begin to close.

**CTL DOOR OPEN TIMER** (Range: 2.0 - 60.0 seconds) - Used when either CTL or CTF spare inputs are programmed. This timer is used to indicate how long the doors should remain open after lowering to the lobby floor when the CTL or CTF spare input is activated.

**DOOR BUZZER TIMER** (Range: 0 - 30 Seconds) - This timer determines the length of time the door buzzer sounds before the doors are automatically closed.

**OPN/CLS INTRLOCK TIMER** (Range: 050ms - 950ms, 50ms increments) Introduces a delay when closing or opening doors are abruptly reversed (i.e., photo eye activation, door button press, etc.). This may be required if the door operator is sensitive to such reversal due to de-bounce capability. Set to NONE if unnecessary.

**FIRE PH1 RECLOSE TIMER** (Range: None or 1 - 120 seconds) - If set to a value other than NONE, the doors will close after the set number of seconds following a Fire Service Phase 1 recall. Doors may be opened using in-car or hall door open buttons.

**SYNC. OP. DELAY TIMER** (Range: None or 1 - 120 seconds) - If Synchronization Operation has been requested via the SYNCI input (see “[SYNCI](#)” on page 5-37) or the Sync. Op. Days timed feature (see “[SYNC. OP. DAYS](#)” on page 5-54), this timer will start when the car becomes idle (no demand) and the doors are closed and locked. If Retiring Cam = Yes, the doors would only need to be closed, not locked, before the timer starts. The timer must then expire before the car will respond to the request for Synchronization Operation. If the door opens or the car moves before the timer expires, the timer is reset and will begin again once the car is idle with doors closed and locked.

## Gongs/Lanterns Menu Options

**MOUNTED IN HALL OR CAR?** This option determines when the lanterns and gongs will be activated, as the car slows into the floor for hall mounted fixtures or after the door lock opens for car mounted fixtures. If both types of lanterns will be used, then the Hall option is recommended.

**DOUBLE STRIKE ON DOWN?** This option causes a double strike of the lanterns and gongs, if the direction preference of the car is down.

**PFG ENABLE BUTTON?** (Passing Floor Gong Enable Button) If this option is selected, the Passing Floor Gong will only be operative when initiated by a momentary pressure pushbutton. Once initiated, the Passing Floor Gong will operate for the current direction of travel but will be rendered inoperative when the car reverses direction. The PFGE spare input (see “[Spare Inputs Menu Options](#)” on page 5-29) should also be selected if this option is turned *ON*.

**EGRESS FLOOR ARRIVAL GONG? / MAIN EGRESS FLOOR #** To program this option (Michigan Code), set one of the spare outputs to EFG. Then, set EGRESS FLOOR ARRIVAL GONG? to *NO* (no gong) or press *S* to select the floor number where the gong should activate (after the door lock opens). If *S* is pressed, the display will read MAIN EGRESS FLOOR #1. Press *S* until the desired floor number is displayed.

**CAR LANTERN DOOR FULLY OPEN** If *NO*, the car lantern turns on when the doors begin to open and remains on until the doors are fully closed. If *YES*, the car lantern turns on when the doors are fully open and turn off when the doors begin to close.

## Spare Inputs Menu Options

The first 10 spare input terminals are located on the HC-CTL board. Additional spare inputs are available on additional HC-UIO Universal Input/Output board (see [“HC-UIO Spare Input / Output Assignments”](#) on page 6-61).

If your installation uses MC-CPI serial control panel boards in the car, spare inputs are also available on these boards and will show up in the Spare Inputs menu as inputs to CPI-F and CPI-Fx, or CPI-R depending upon the car control panel and rear door board configuration. If the job has MC-CPI boards, unused spare inputs to these boards must be set to NOT USED. If controller software is upgraded in the field, it is very important to check programmable CPI board inputs and verify unused inputs are set to NOT USED. Please refer to [“MC-CPI Car Panel Interface Board”](#) on page 6-62.

“Spare” inputs are inputs that can be assigned to a physical board connection through software, allowing great flexibility in configuring a controller to meet specific requirements. Any of these spare inputs (SP1, SP2, ...) may be used for any of the input signals listed in [Table 5.6](#) on page 30.

## Viewing and Assigning Spare Inputs

Virtually every elevator installation requires some inputs or outputs that are not “standard.” Perhaps because one site has elevator security requirements while another does not, etc. To accommodate these features without requiring custom software, MCE defines many spare inputs and outputs in standard software that can be assigned to a physical connector and used as needed. Jobs are well defined and tested before shipment, allowing MCE, in most cases, to assign and label these non-standard inputs or outputs and show them in the job prints.

To view assigned spare inputs:

1. Put the car on Inspection and set Function switch F1 up (all others down).
2. Press the N button to cycle through menus until you see “Spare Inputs Menu,” then press the S button to select that menu.
3. The display will show the first “spare” (assignable) connector on the HC-CTL board and the input assigned there.
4. Press the N button to cycle through available assignable connectors in your system and the input, if any assigned.
5. If you want to assign an input to an unused connector, cycle to the desired connector then begin pressing the S button to cycle through available input signals in the order they are shown in the table below. (You can press and hold S to continuously move through the inputs in their numeric/alphabetic order.)
6. When the desired input is shown, press N (it also may be held to cycle) until the Spare Inputs menu is completed and the display again shows the top level menus. Press N until the Save screen is displayed. Save your changes by pressing S when prompted.

After selecting an input, you can also press N and + buttons together to go immediately back to the top level menus, then continue to press N until the Save menu is displayed.

Table 5.6 Spare Inputs Menu Options

Spare Inputs Menu Options	
<b>2AB</b>	Monitoring input for the 2AB relay coil - If the 2AB relay is ON, the R2AB input will be OFF. R2AB should always be the opposite of 2AB otherwise, the 2AB redundancy fault is logged and the elevator shuts down.
<b>ABI</b>	Alarm Bell Input - This input monitors the car through remote monitoring software. There are three conditions that will display a warning on the screen. First, if the Alarm Button is pressed when the car is stopped outside of the door zone. Next, if the Alarm Button is pressed four times in 60 seconds without the car moving. And lastly, if the car fails to complete an LSA movement check after being idle for 10 minutes at a landing. All of these failures will alert the monitoring station.
<b>ACI</b>	Reserved for future use.
<b>ALI</b>	Alternate Lobby Input - The ALI input is used to substitute the Main Lobby floor value with an Alternate Lobby floor value. When the ALI input is activated, the lobby value is taken not from the LOBBY parameter, but from the ALTLBY parameter. The ALTLBY floor must be specified before using the ALI input.
<b>ALV</b>	Alive Input - This input is used in a duplex configuration and is received from the other car. If the input is on for this car, it states that the other car is powered. This input is used in emergency power applications.
<b>API</b>	Alternate Parking Input - This input is used to determine whether to park at the primary parking floor, or at the alternate parking floor. When API is low, the car will park at the primary floor. When API is high, the car will park at the alternate floor.
<b>ARST</b>	Alarm Reset input - When the ARST input is activated, the alarm outputs DISL and DISB are reset.
<b>ATS</b>	Attendant Service Input - When the ATS input is activated, the car is under the control of the attendant (starting, stopping, direction of travel). Doors open automatically when the car is stopped at a landing. Doors are closed only through constant pressure on the door close button, car call button, or either car direction button (UPI and DNI). The attendant may cause the car to bypass all hall calls by activating the "non-stop button" (NSI). The ATSOPT option must also be enabled. While the car is on Attendant Service, all of the Load Weigher Functions (LLW, HLW, OLW) are cleared.
<b>AUTO</b>	Emergency Power Auto Selection Input - This input is for duplexes only. When activated, one of the cars will be automatically chosen to run "normally" on emergency power. The dispatcher makes this decision, and will choose itself if able to run. The slave will be chosen if the dispatcher is unavailable to run. See also the ALV input.
<b>AXR</b>	Auxiliary Reset Input - Usually connected to a push button on a controller to reset redundancy error conditions.
<b>BAB</b>	Monitoring input for the BAB relay coil. If the BAB relay is ON, the RBAB input will be OFF. RBAB should always be the opposite of BAB otherwise, the BAB redundancy fault is logged and the elevator shuts down.
<b>BSI</b>	Building Security Input - This input is used to activate MCE Security when the MASTER SOFTWARE KEY, in the Extra Features Menu ( <a href="#">see "MASTER SOFTWARE KEY" on page 5-50</a> ), is set to ENABLED.
<b>CCC</b>	Car Calls Cancel Input - Activation of this input will unconditionally cancel car calls. Because this input has no logical qualification in the software, it is highly suggested that necessary qualification be done in external circuitry (e.g., disable the signal feeding this input when on Fire Service Phase II).
<b>CNP</b>	Contactors Proof Input - This input monitors the normal condition of motor/start contactors and will shut down the car if the contactor fails to make or break contact properly. Generates a Contactor Proofing Redundancy Failure message.



Table 5.6 Spare Inputs Menu Options

Spare Inputs Menu Options	
<b>CR1 - CR8</b>	Card Reader Front Landing 1-8 Inputs - These inputs are used to enable the registration of secured car calls for front landings.
<b>CR1R - CR8R</b>	Card Reader Rear Landing 1-8 Inputs - These inputs are used to enable the registration of secured car calls for rear landings.
<b>CRO</b>	Card Reader Override input - This input is used to override the Card Reader Security Inputs. Activating this input will allow car calls to be registered without restriction.
<b>CTF</b>	Car to floor Input - This input is used to return the car to a previously selected floor. The return floor is selected using the parameter CAR TO FLOOR RETURN FLOOR in the EXTRA FEATURES MENU. When activated, this input will cause the car to immediately become non-responsive to hall calls, and will prevent the registration of new car calls. The car will be allowed to answer all car calls registered prior to activation of the CTF input. Once all car calls have been answered, the car will travel to the return floor, perform a door operation, and will be removed from service.
<b>CTL</b>	Car-to-Lobby Input - When activated, this input will cause the car to immediately become non-responsive to hall calls, and will prevent the registration of new call calls. The car will be allowed to answer all car calls registered prior to activation of the CTL input. Once all car calls have been answered, the car will travel to the lobby landing, perform a door operation, and will be removed from service.
<b>CTST</b>	Capture for Test Input - This input will cause the car to bypass Hall Calls and disable the gongs. Car Calls, however, will still be answered and allowed to be entered.
<b>DCL</b>	Door Close Limit Input - Breaks when the car door is approximately 1 inch from being closed. DCL input will be low once the doors fully close. Moving the door approximately 1 inch will reapply power to the DCL input due to the switch making up.
<b>DCLC</b>	Doors Closed Contact Input - This input, when active (high), tells the computer the doors are closed on Retiring CAM (RETCAM) jobs. Since the doors don't lock until the car is ready to move, the computer needs to see this input to know when the doors are closed.
<b>DCLR</b>	Doors Closed Contact Rear input - When active (high) tells the computer the doors are closed on Retiring CAM (RETCAM) jobs. Since the doors do not lock until the car is ready to move, the computer needs to see this input to know when the doors are closed.
<b>DHLD</b>	Door Hold Input - This input will open and hold the doors open for as long as it is active and additionally for the DLHD timer value. <a href="#">Please refer to "DOOR HOLD INPUT TIMER" on page 5-27.</a> DBC input and car call pressure will cancel DHLD timing. Fire Service disables the input.
<b>DHLDR</b>	DHLD input for Rear Doors - See description of DHLD.
<b>DLI</b>	Dispatch Load Input - A load weigher device can be connected to this input. When the input is activated, the door dwell time will be eliminated when the elevator has an up direction at the Lobby Floor.
<b>DLS</b>	Door Lock Sensor Input - Monitors the state of the contacts in the landing door lock string. Power will be present on the DLS input when all the landing doors are closed and locked. Needed for CSA code with Door lock bypass requirement. NOTE: It is mandatory to have the DCL spare input programmed whenever DLS is used.
<b>DLSR</b>	Door Lock Sensor Rear Input - See description for "DLS".
<b>DNI</b>	Down Input (Attendant Service) - This input is used by the attendant during Attendant Service operation to establish a direction preference. Pushing the "DOWN" button in the car will activate this input, which will cause the computer to generate SDA (down direction preference) and DSHT (door shortening) to close the doors.
<b>DOL</b>	Door Open Limit input - Active high input from door open limit switch.

Table 5.6 Spare Inputs Menu Options

Spare Inputs Menu Options	
<b>DOLR</b>	Door Open Limit Rear input - Active high input from rear door open limit switch.
<b>DPM</b>	Front Door Position Monitoring - Makes when the car door is approximately 1 inch from being closed. DPM input is active once the door fully closes. Moving the door approximately 1 inch removes power from the DPM input due to the switch opening.
<b>DPMR</b>	Rear Door Position Monitoring - Makes when the car door is approximately 1 inch from being closed. DPMR input will be active once the door fully closes. Moving the door about 1 inch will remove power from the DPMR input due to the switch breaking.
<b>DSTI</b>	Door Stop Input - If the doors are opening or closing when this input is detected, the door operation will stop. DOF and DCF/DCP flags are cleared. If the DSTI input is momentary, the doors may then be opened or closed by the DOB or DBC inputs. If the DSTI input is constant, DOB or DCB will not override it. This operation will not function in Fire Service, Inspection or Independent service.
<b>DSTIC</b>	Door Stop Input Complement – Active low (see DSTI, Door Stop Input)
<b>DSTICR</b>	Door Stop Input Complement Rear - Active low (see DSTIR, Door Stop Input Rear)
<b>DSTIR</b>	DSTI for rear doors - See description under DSTI.
<b>DZRX</b>	Door Zone Rear Auxiliary input - This input may be used instead of the DZR (Door Zone Rear) input on the HC-RDR board. It may be assigned to SPIN1 - SPIN6 on the HC-CTL board or to an HC-UIO board input.
<b>DZX</b>	Door Zone Auxiliary input - This input may be used instead of the DZF (Door Zone Front) input on the HC-CTL board. It may be assigned to SPIN1 - SPIN6 on the HC-CTL board or to an HC-UIO board input.
<b>ECRN</b>	Emergency Car Freeze Input - This input is used with EMP-OVL product and will cause the car to freeze, allowing others cars to return on emergency power. Used with EPR input to select car to run (must be programmed).
<b>EMSC</b>	Emergency Medical Service (EMS) in car switch - When activated, this input will put the car on EMS phase two upon completion of the EMS phase one return.
<b>EMSH</b>	Emergency Medical Service (EMS) hallway switch - When activated, this input will initiate an emergency recall to the designated EMS floor.
<b>EPI</b>	Emergency Power Input - This input indicates loss of the commercial power when it is deactivated. <a href="#">Please refer to “EMERGENCY POWER OPERATION?/EMERGENCY POWER RETURN FLOOR” on page 5-48.</a>
<b>EPR</b>	Emergency Power Return Input - This input is used with the EMP-OVL product. When activated, this input initiates lowering the car to the lobby on emergency power. The ECRN input must also be programmed.
<b>EPRUN</b>	Emergency Power Run Input - This input is wired to the “Run” switch for emergency power car selection. The “dispatcher” in a PTHC duplex system will reference this input when deciding which car should be allowed to run “normally” on emergency power. Each car should have its own EPRUN input. Whichever one is selected, will be the car chosen to run on Emergency Power Phase II.
<b>EPSTP</b>	Emergency Power Stop Input - When activated before the lowering sequence, this input will keep the cars in a frozen state preventing the emergency power transition timer from running. It is usually used for emergency power interface with other systems to delay the lowering sequence.
<b>EQH</b>	Earthquake Hydro input - This is a latching input. When activated the elevator will stop at the next available landing and shut down. To return the car into service the fault reset button must be pressed.

Table 5.6 Spare Inputs Menu Options

Spare Inputs Menu Options	
<b>ERU</b>	Emergency Return Unit Input - When activated, this input will initiate an emergency return to the bottom floor. Upon arrival, the car will be shut down and the doors will cycle for the predetermined time of the ERU timer. The doors will remain open if the ERU timer is set to zero. This input overrides fire service.
<b>ESS</b>	Elevator Shutdown Input - When this input is activated, the car stops at the next landing in the direction of travel, cycles the doors and shuts down. This input is bypassed by Fire, Inspection, Independent, Attendant and Hospital service.
<b>EXMLT</b>	External Motor Limit Timer Input - When activated, this input will initiate an emergency return to the bottom floor (all car calls immediately canceled). Upon arrival at the bottom floor, the car will be shut down and the doors will cycle for the field adjustable SDT time. Note: If it is required to cycle the doors for a predetermined time, then ERU should be used instead.
<b>EXMLTC</b>	Complimented EXMLT Input - This input provides reverse logic for the EXMLT function. EXMLT operation is initiated when this input goes low.
<b>FCCC</b>	Fire Phase II Call Cancel Button Input - When activated during Fire Phase II operation, all registered car calls will be canceled.
<b>FCHLD</b>	Fire Phase II Door Hold Input - When activated during Fire Phase II operation, fully open doors will not be allowed to close. The "HOLD" position of the In-car Fireman's Service switch is wired to this input.
<b>FCOFF</b>	Fire Phase II OFF Input - Used to take the elevator out of Fire Phase II service. The "OFF" position of the In-car Fireman's Service switch is wired to this input.
<b>FRAA</b>	Fire Phase I Second Alternate Input - Required by the Detroit fire code. When activated, this input will initiate an emergency return to the second designated alternate floor (FRA must also be active). The alternate fire return floor sensor should activate this input.
<b>FRAON</b>	Fire Phase I Alternate Switch ON Position Input - This fire service switch input will be seen as second priority to the main switch input (FRON) but will override the sensor inputs. When the input is seen as ON, the car will return to the alternate fire floor.
<b>FRBYP</b>	Fire Phase I Switch BYPASS Position Input - This input, when activated, will cause the system to ignore the fire sensors (restoring normal fire service status if the fire service switch is not active) and will unlatch the current fire sensor status.
<b>FRHTW</b>	Hoistway Fire Sensor - (Normally high) Deactivation of the input will initiate recall to the main fire floor and cause the FWL output to flash.
<b>FRMR</b>	Machine room fire sensor - (Normally high) Deactivation of the input will initiate recall to the main fire floor and cause the FWL output to flash.
<b>FRON</b>	Fire Phase I Switch ON Position Input - When activated, this input will place the system in Fire Service Phase I operation. The "ON" position of the fire recall switch is typically wired to this input.
<b>FRON2</b>	Fire Phase I Switch ON Position Input (additional input - same as FRON).
<b>FRSA</b>	Alternate Fire Service - normally active input. When this input goes low, Alternate Fire Service operation is initiated and the FWL output (Fire Warning Light) will flash.
<b>FRSM</b>	Main Fire Service - This is a normally active input. When this input goes low, Main Fire Service operation is initiated and the FWL output (Fire Warning Light) will flash.
<b>GS</b>	Gate Switch Input - Makes up when the car door is approximately 1 inch from fully closed. With the car door closed, there should be power on the GS input. This input is used for CSA door lock bypass and redundancy logic. NOTE: It is mandatory to have the DCL spare input programmed whenever GS is used.

**Table 5.6 Spare Inputs Menu Options**

<b>Spare Inputs Menu Options</b>	
<b>GSR</b>	Gate Switch Rear Input - When activated, this input indicates that the rear car gate is closed. This input is used for CSA door lock bypass and redundancy logic.
<b>HBF</b>	Hall Call Bus Failure input - This input from the group controller indicates that the serial hall bus has failed. Without hall call direction, local cars will begin "stop at each floor" operation to collect passengers and continue to provide service to the building.
<b>HCC</b>	Hall Call Cancel Input - When activated all registered hall calls are canceled.
<b>HCR1 - HCR8</b>	Hall Card Reader Front Landing 1-8 Inputs - These inputs are used to enable the registration of secured hall calls for front landings.
<b>HCR1R - HCR8R</b>	Hall Card Reader Rear Landing 1-8 Inputs - These inputs are used to enable the registration of secured hall calls for rear landings.
<b>HCRO</b>	Hall Card Reader Override input. When active, causes the car to bypass Per Floor Hall Card Reader security inputs. Hall Calls will be permitted without enabling the Hall Card Reader inputs.
<b>HDCB</b>	Front Hall Door Close Button Input - When activated, this input will initiate door closing for the front door. It is disabled during In-car Fireman's Operation (Fire Service Phase II).
<b>HDCBR</b>	Rear Hall Door Close Button Input - When activated, this input will initiate door closing for the rear door. This input is disabled during In-car Fireman's Operation (Fire Service Phase II).
<b>HDOB</b>	Front Hall Door Open Button Input - When activated, this input will initiate door opening for the front door. This input is disabled during In-car Fireman's Operation (Fire Service Phase II).
<b>HDOBR</b>	Rear Hall Door Open Button Input - When activated, this input will initiate door opening for the rear door. This input is disabled during n-car Fireman's Operation (Fire Service Phase II).
<b>HDSTI</b>	Front Hall Door Stop Input - This input will cause the front door to stop. Subsequently either the front door close or front door open buttons must be pressed to resume door operation. This input is disabled during In-car Fireman's Operation (Fire Service Phase II).
<b>HDSTIR</b>	Rear Hall Door Stop Input - This input will cause the rear door to stop. Subsequently either the rear door close or rear door open buttons must be pressed to resume door operation. This input is disabled during In-car Fireman's Operation (Fire Service Phase II).
<b>HEATD</b>	Heat Detector Input - This input is used for Detroit Fire Code jobs. It is connected to a heat detector located in the machine room and is used to stop the car at the next floor and open the doors (same as PTI). Once the doors are fully open, the HDSC spare output is turned off which indicates that it is okay to remove power from the controller and activate sprinklers in the machine room.
<b>HLI</b>	Heavy Load Input - This input indicates that the car is loaded to the point at which it should no longer accept hall call assignments (heavy load bypass). A "discrete" load weigher contact is typically wired to this input, usually indicating that the load is 75%-80% of full load.
<b>HML</b>	Home Landing Input - This input is used with the primary parking feature and will determine whether the car will park or not. The HLSOPT option must also be enabled to allow this feature to work.

Table 5.6 Spare Inputs Menu Options

Spare Inputs Menu Options	
<b>HOSP</b>	In-car Hospital Service Switch Input - This input is used to initiate Hospital Service Phase 2 operation. Typically, this input is wired to a keyed hospital service switch that is located inside the car. Upon activation, the car will accept a call for any floor, and proceed nonstop to that floor after the doors close. Deactivation of the input restores normal operation of the car.
<b>INA</b>	Monitoring input for the INAX relay coil.
<b>INSDN</b>	Inspection Down Input - This input is used to indicate that there is an intent to move in the down direction while on Inspection operation.
<b>INSUP</b>	Inspection Up Input - This input is used to indicate that there is an intent to move in the up direction while on Inspection operation.
<b>IRCOF</b>	Front Infrared Cutout. - This is a normally active input. When this input goes low, the infrared detector signal is ignored for the <b>front</b> door only and the door will always close at reduced torque and speed, i.e., nudge closed unless the door requires a constant door close button signal to close. In this case the door will close at full speed.
<b>IRCOR</b>	Rear Infrared Cutout - This is a normally active input. When this input goes low, the infrared detector signal is ignored for the <b>rear</b> door only and the door will always close at reduced torque and speed, i.e., nudge closed unless the door requires a constant door close button signal to close. In this case the door will close at full speed.
<b>LLI</b>	Light Load Input - When activated the elevator will only allow the number of car calls specified by the Light Load Car Call Limit parameter to be registered. If more are registered, all car calls are canceled. A discrete load weigher contact is typically wired to this input, indicating that a very minimal passenger load exists in the car. <a href="#">Please refer to "LIGHT LOAD WEIGHING? / LIGHT LOAD CAR CALL LIMIT" on page 5-48.</a>
<b>LOS</b>	Low Oil Switch - (PHC controllers) - This input is connected to a level switch in the oil reservoir. Once activated, the car will immediately lower to the bottom landing and cycle the doors. To clear this condition, the car must be put on inspection and then back into normal operation, or the RESET button must be pressed.
<b>LSR</b>	Landing System Redundancy Input - This input is used for redundancy checking. It monitors the door zone (DZ) level down (LD) circuits. On any run between floors, we expect the LSR input to go low at least once. If, however the DZ sensor has failed closed, power will be present continuously on the LSR input and the car will not be permitted to restart. "LANDING SYSTEM REDUNDANCY FAILURE" will be displayed on the LCD display. If either the LU or LD sensors failed closed, the controller will not permit the car to restart.
<b>LWB</b>	Load Weigher Bypass - This input is used to bypass the load weigher inputs (LLI, HLI, OVL and DLI).
<b>MNO</b>	Manual Override - When activated, automatic lowering is overridden. The car will recall to the next available landing and complete the recall process.
<b>NSI</b>	Non-Stop Input (Attendant Service) - Activation of this input will cause the car to bypass all hall calls. The input is enabled only when the car is in Attendant operation.
<b>OVL</b>	Overload Input - While the car is stopped at a landing with the doors open, the activation of this input will hold the doors open until the overload condition is cleared by deactivating the input. Fire Service will bypass OVL.
<b>OVL2</b>	Overload 2 Input - While on Fire Phase II, when the car is stopped at a landing with the doors open, activation of this input will hold the doors open until the overload condition is cleared by deactivating the input (only used for the ANSI A17.1-2000 fire code).

**Table 5.6 Spare Inputs Menu Options**

<b>Spare Inputs Menu Options</b>	
<b>PFGE</b>	Passing Floor Gong Enable Input - Used mostly on New York City jobs. Normally there is not an output from the PFG. When this input is momentarily activated there will be a PFG output as the car passes a floor until the elevator reverses direction (also referred to as "S" button). <a href="#">Please refer to "PFG ENABLE BUTTON? (Passing Floor Gong Enable Button)" on page 5-28.</a>
<b>PHERX</b>	Rear Photo Eye Auxiliary input - This input may be used instead of the PHER (Photo Eye Rear) input on the HC-RDR board. It may be assigned to SPIN1 - SPIN6 on the HC-CTL board or to an HC-UIO board input.
<b>PHEX</b>	Photo Eye Auxiliary input - This input may be used instead of the PHE (Photo Eye) input on the HC-CTL board. It may be assigned to SPIN1 - SPIN6 on the HC-CTL board or to an HC-UIO board input.
<b>PITFLD</b>	Pit Flood - Activated by pit flood sensor. When activated, the car recalls to the lowest landing above flood level, after which it returns to normal service without serving the inaccessible floors. Renders the floors set in the Extra Features menu "# of flrs below floor level" inaccessible. Fire, Parking, and Emergency floors, if below flood level, will be automatically set to the first available landing above floor level.
<b>PSS</b>	Pressure Switch Input - When activated (low), this input will cause the elevator to stop immediately.
<b>PTI</b>	Power Transfer Input - When this input is activated, it causes the car to stop at the next landing in the direction of travel, open the doors (in accordance with the "LEAVE DOORS OPEN ON PTI/ESS?" parameter) and shut down. This input is typically used with Emergency Power when transferring from normal power to emergency power (testing) or emergency power to normal power.
<b>PTIC</b>	Complimented PTI Input - Provides reverse logic for the PTI function. PTI operation is initiated when this input goes low.
<b>R2AB</b>	Redundancy monitoring input from the 2AB relay contact. (See description of 2AB input).
<b>R5, R4, R3, R2</b>	Floor Encoding Inputs - These inputs are required for jobs with absolute floor encoding. <a href="#">Please refer to "FLOOR ENCODING INPUTS?" on page 5-48.</a>
<b>R2L</b>	Redundancy 2L bus. Used to monitor the normally closed contact of an additional 2L relay.
<b>RBAB</b>	Redundancy monitoring input for the BAB relay contact. (See description of BAB input).
<b>RDLSR</b>	Rear Door Lock Relay Redundancy input (CSA Redundancy) - This input is used to monitor the state of the DLSR relays (there are 2 relays). This input is activated if either one of the two relays is "picked" (a normally open contact from one relay is wired in parallel with a normally open contact from the other relay to feed this input). The logic compares the state of the RDLSR input with the state of the DLSR input (the DLSR input monitors the string of actual door lock contacts) to see if one of the two DLSR relays has failed in the "picked" mode (if DLSR=0 and RDLSR=1, a failure is declared).
<b>REO</b>	Re-Open Input - Only used on jobs with Houston fire code. This code requires that the doors close after completing a Fire Phase I return. There is a key switch in the hallway used by the fire person to reopen the doors at the main recall floor.
<b>REOA</b>	Re-Open Input Alternate - Houston fire code requires that doors close after completing a Fire Phase I return. A key switch in the hallway connected to this input is used by the fire person to reopen the doors at the Alternate recall floor.
<b>RFV</b> ASME A17.1-2000	Redundancy Fast Valve - Used to monitor the up/down fast valve relay when the VALVE TYPE option (see <a href="#">"VALVE TYPE:" on page 5-54</a> ) is set to PILOT RELAYS.

Table 5.6 Spare Inputs Menu Options

Spare Inputs Menu Options	
<b>RGS</b>	Redundancy Gate Switch (front) - This input is used to monitor the state of the GS relays (there are 2 relays). This input is activated if either one of the two relays is "picked" (a normally open contact from one relay is wired in parallel with a normally open contact from the other relay to feed this input). The logic compares the state of the RGS input with the state of the GS input (the GS input monitors the actual car gate contact) to check to see if one of the two GS relays has failed in the "picked" mode (if GS=0 and RGS=1, a failure is declared).
<b>RGSR</b>	Redundancy Gate Switch (rear) - This input is used to monitor the state of the GSR relays (there are 2 relays). This input is activated if either one of the two relays is "picked" (a normally open contact from one relay is wired in parallel with a normally open contact from the other relay to feed this input). The logic compares the state of the RGSR input with the state of the GSR input (the GSR input monitors the actual rear car gate contact) to check to see if one of the two GSR relays has failed in the "picked" mode (if GSR=0 and RGSR=1, a failure is declared).
<b>RINAX</b>	Redundancy monitoring input for the INAX relay contact.
<b>RSV</b> ASME A17.1-2000	Redundancy Slow Valve - Used to monitor the up/down slow valve relay when the VALVE TYPE option (see "VALVE TYPE:" on page 5-54) is set to PILOT RELAYS.
<b>SAB</b>	Sabbath Operation Input - This input is used to select Sabbath Operation. This mode will move the car through the hoistway, stopping at landings that are programmed in the Extra Features Menu.
<b>SIMP</b>	Simplex Input - Activation of this input will cause a duplex car to behave as a simplex. As a simplex, the car will respond to hall calls registered on its own call circuitry (it will not accept hall calls assigned to it by another controller connected to it) and will perform its own parking function (independent of the other controller).
<b>STAR-TIN</b>	Start Input - The STARTIN input is used for the START position of the three position Fire Phase II switch for Australian jobs. When activated, it will cause the front and rear doors to close. The car will not proceed to answer car calls during Fire Phase II until the STARTIN input has been activated.
<b>SWG</b>	Swing Input. When active will disconnect from the group and act as a simplex, responding to calls from its independent riser. Disable Local Hall Calls, page 5-19, must be set to NO.
<b>SYNCI</b>	Synchronization Input - (PHC controllers) - Momentary activation of this input will initiate the jack synchronization function once the Sync. Op Delay Timer has expired (see "SYNC. OP. DELAY TIMER" on page 5-28). This function is intended to equalize hydraulic pressure in systems that utilize more than one piston to move the car (generally two). When appropriate (the car is idle), the car will be taken to the bottom landing. The down normal limit switch is bypassed by activation of a relay connected to the SYNC output, and the car is moved at slow speed in the down direction. The down slow valve circuits are energized for 30 seconds to ensure that the car has been lowered all the way to the buffer. Once this timer elapses the car is moved back up to the bottom landing.
<b>TEST</b>	TEST Switch Input - This input monitors the TEST/NORM Switch located on the Relay Board to differentiate between Test and Independent Operation. This input is normally high and will go low when the switch is placed in the Test position.
<b>TSLB</b>	Bottom Terminal Slow Limit Input - This input will cause high speed to drop if deactivated while the elevator is traveling in the down direction at high speed.
<b>TSLT</b>	Top Terminal Slow Limit Input - This input will cause high speed to drop if deactivated while the elevator is traveling in the up direction at high speed.
<b>UFL</b>	Up Final Limit Input - This is a latching input that monitors the up final limit. Deactivation of this input will shut the elevator down and require a manual reset.

**Table 5.6 Spare Inputs Menu Options**

<b>Spare Inputs Menu Options</b>	
<b>UPI</b>	Up Input (Attendant Service) - This input is used by the attendant during attendant service operation to establish a direction preference. Pushing the “UP” button in the car will activate this input, which will cause the computer to generate SUA (up direction preference) and DSHT (door shortening) to close the doors.
<b>VCI</b>	Viscosity Control Input - Activation of this input will initiate the Viscosity Control Function. When appropriate (when the car is idle and “in service”) the Viscosity Control Function will move the car to the bottom landing and activate the pump motor (without energizing the up direction valve circuits). The SST output and the UPDO input are turned on initially, with the UPDO output remaining on only for a few hundred milliseconds. This will allow the AA circuit to be activated, and will remain activated as long as the SST output remains on. The pump is run for 3 minutes, turned off for 9 minutes, turned on for 3 minutes, and so on and so forth (until the VCI input is deactivated). Registration of any call will preempt the Viscosity Control Function, as will any special operation (e.g., Fire Service, Independent Service, etc.).
<b>WLD</b>	Emergency Dispatch Input - Activation of this input will cause the Wild operation (emergency dispatching) to be disabled. This input was created to allow building personnel or elevator maintenance personnel to disable emergency dispatching on one or more cars in a multi-car system. As an example, if the dispatcher of an 8-car group were to fail, the building may only want 3 cars to run on “wild operation”. The remaining 5 cars would be inhibited from running on “wild operation” by the activation of the WLD input.
<b>WPIx</b> (x = A thru H)	Wandering Patient Security (Bracelet Security) inputs - These inputs work in conjunction with the WPIx LANDING parameters in the Extra Features Menu. The landing and side (Front, Rear and Both) must be set for each WPIx input programmed. When a WPIx input is activated, hall calls to the landing and side associated with that input shall be disabled. If the elevator is already located at that landing with the doors open, it will be prevented from leaving that landing and shut down.



## Spare Outputs Menu Options

The first 4 spare output terminals are located on the HC-CTL board. Additional spare outputs are available on additional HC-UIO Universal Input/Output boards (see “HC-UIO Spare Input / Output Assignments” on page 6-61).

If your installation uses MC-CPI serial control panel boards in the car, spare outputs are also available on these boards and will show up in the Spare Outputs menu as outputs from CPI-F and CPI-Fx, or CPI-R depending upon the car control panel and rear door board configuration. If the job has MC-CPI boards, unused spare outputs from these boards must be set to NOT USED. If controller software is upgraded in the field, it is very important to check programmable CPI board outputs and verify unused outputs are set to NOT USED. Please refer to “MC-CPI Car Panel Interface Board” on page 6-62.

“Spare” outputs are outputs that can be assigned to a physical board connection through software, allowing great flexibility in configuring a controller to meet specific requirements. Any of these spare outputs may be used for any of the output signals listed in Table 5.7 on page 40.

### Viewing and Assigning Spare Outputs

Virtually every elevator installation requires some inputs or outputs that are not “standard.” Perhaps because one site has elevator security requirements while another does not or uses a switch to detect when the machine brake is picked, etc. To accommodate these features without requiring custom software, MCE defines many spare inputs and outputs in standard software that can be assigned to a physical connector and used at need. Jobs are well defined and tested before shipment, allowing MCE to assign, label, and show in the job prints these non-standard inputs or outputs in most cases.

To view assigned spare outputs:

1. Put the car on Inspection and set Function switch F1 up (all others down).
2. Press the N button to cycle through menus until you see “Spare Outputs Menu,” then press the S button to select that menu.
3. The display will show the first “spare” (assignable) connector and the output assigned there.
4. Press the N button to cycle through available assignable connectors in your system and the output, if any assigned.
5. If you want to assign an output to an unused connector, cycle to the desired connector then begin pressing the S button to cycle through available output signals in the order they are shown in the table below. (You can press and hold S to continuously move through the outputs in their numeric/alphabetic order.)
6. When the desired output is shown, press N (it also may be held to cycle) until the Spare Outputs menu is completed and the display again shows the top level menus. Press N until the Save screen is displayed. Save your changes by pressing S when prompted.

Note

After selecting an output, you can also press N and + buttons together to go immediately back to the top level menus, then continue to press N until the Save menu is displayed.

Table 5.7 Spare Outputs Menu Options

Spare Outputs Menu Options	
<b>702 - 709</b>	Front Down Hall Call Indicator Outputs. These outputs are typically used to connect hall gongs or chimes. The appropriate output will activate as the elevator is slowing down to a landing. Do not use if a dedicated HC-UIO board is used for Hall Call Indicators.
<b>702R - 709R</b>	Rear Down Hall Call Indicator Outputs. These outputs are typically used to connect hall gongs or chimes. The appropriate output will activate as the elevator is slowing down to a landing. Do not use if a dedicated HC-UIO board is used for Hall Call Indicators.
<b>801 - 808</b>	Front Up Hall Call Indicator Outputs. These outputs are typically used to connect hall gongs or chimes. The appropriate output will activate as the elevator is slowing down to a landing. Do not use if a dedicated HC-UIO board is used for Hall Call Indicators.
<b>801R - 808R</b>	Rear Up Hall Call Indicator Outputs. These outputs are typically used to connect hall gongs or chimes. The appropriate output will activate as the elevator is slowing down to a landing. Do not use if a dedicated HC-UIO board is used for Hall Call Indicators.
<b>900</b>	Car Call Cancellation Output - This output is generated at the time of registration of a car call. This output is used to comply with specific handicap codes ( <i>barrier-free</i> codes) that require an audible acknowledgment of car call registration
<b>ABZ</b>	Attendant Service Buzzer Output - This output is generated momentarily when a hall call button is pushed while the elevator is on attendant operation. It is used for an in-car buzzer to alert the attendant.
<b>BOTTOM</b>	Bottom landing output - Activates when the car reaches the bottom landing.
<b>CCDE</b>	Car Call Disconnect Enable Output - This output comes <i>ON</i> when the car calls are canceled during photo-eye anti-nuisance operation.
<b>CCT</b>	Car Call Time Flag Output - This output represents the state of the CCT flag. It is activated when a car call is canceled, and is deactivated when the door dwell time elapses (or is canceled by pressing a car call button or door close button).
<b>CD</b>	Car Done Returning on Emergency Power Output - This output is active when the car has finished returning on emergency power or when it has been determined that the car cannot lower.
<b>CEPR</b>	Completed Emergency Power Return. Generated when the car has completed emergency power return to the recall landing and is parked with doors open.
<b>CFLT</b>	CSA FAULT OUTPUT - This output turns on when there is a CSA Redundancy fault condition (CNP, ILO and UDF only). It is currently used for Canadian Standards Association (CSA) code only. If this is the applicable code for the installation, please refer to the Compliance Report included with the job.
<b>CGED</b>	Car Gong Enable Down Output - This output is generated to activate the in-car gong/lantern assembly (front doors). It is activated (usually a double ding: on-off-on) to announce the elevator's intention to go down after the doors start to open. This will happen when a down hall call front has been entered and the car has reached the floor for which that call originated from, or it the doors are open and a car call front is entered for a floor below.
<b>CGEDR</b>	CGED for rear doors Output - Same as CGED, but for the rear gong/lantern assembly.
<b>CGEU</b>	Car Gong Enable Up Output - This output is generated to activate the in-car gong/lantern assembly (front doors). It is activated (usually a single-ding) to announce the elevator's intention to go up after the doors start to open. This will happen when a up hall call front has been entered and the car has reached the floor for which that call originated from, or it the doors are open and a car call front is entered for a floor above.
<b>CGEUR</b>	CGEU for rear doors Output - Same as CGUE, but for the rear gong/lantern assembly.
<b>CGF</b>	Computer Generated Fault Output - This output will come on for any computer generated fault such as Motor/Valve Limit Timer elapsed.

Table 5.7 Spare Outputs Menu Options

Spare Outputs Menu Options	
<b>CHBPO</b> ASME A17.1-2000	Car and Hoistway Door Bypass Output - This output is active whenever a door is being bypassed (car gate or hoistway door for both the front and rear sides).
<b>CRO1 - CRO8</b>	Car Card Reader Front Landing Outputs - These outputs are used to indicate that the associated card reader input has been activated thereby allowing the registration of the car call. Once the call is registered the output will remain active until the call is extinguished. Inputs are available for front landings.
<b>CRO1R - CRO8R</b>	Car Card Reader Rear Landing Outputs - These outputs are used to indicate that the associated card reader input has been activated thereby allowing the registration of the car call. Once the call is registered the output will remain active until the call is extinguished. Inputs are available for rear landings.
<b>CSB</b>	Car Stop Switch Bypass Output - This output is used to provide redundancy for the in-car stop switch function. It is activated during Fire Service Phase I to bypass the in-car stop switch (a similar output is one of the standard outputs). By having this second output, the failure of one of these devices (stuck in the active mode) will not cause the stop switch to be bypassed improperly. Redundancy is required by CSA.
<b>CSEO</b>	Code Sequence Enable Output - This output comes on when car is on security and ready to accept the security code. This output goes off once the code has been accepted in the system, or once the code entry window of time has elapsed.
<b>CSR</b>	Car Selected to Run Output - This output is generated when the car is selected to run on Emergency Power phase 2 (via the AUTO or EPRUN input).
<b>CTLDOT</b>	Car-to-Lobby Door Open Timer Output - This output is generated upon completion of the car to lobby function (the car has returned to the lobby landing, the doors have opened, and the CTL door timer has expired).
<b>DBZF</b>	Front Door Buzzer Output - This output will be active, prior to automatic closing of the front doors, for the length of time determined by the Door Buzzer Timer.
<b>DBZR</b>	Rear Door Buzzer Output - This output will be active, prior to automatic closing of the rear doors, for the length of time determined by the Door Buzzer Timer.
<b>DCFRX</b>	Rear Door Close Function Auxiliary Output - Like DCFX but for rear doors.
<b>DCFX</b>	Door Close Function Auxiliary Output - The Door Close Function signals the controller to attempt to close the doors. Unlike the standard DCF output on the HC-CTL board, this one is disabled on inspection, Fire phase I, or Fire phase II operation.
<b>DCPRX</b>	Rear Door Close Power Auxiliary Output - Like DCPX but for rear doors.
<b>DCPX</b>	Door Close Power Auxiliary Output. Unlike the standard DCP output on the HC-CTL board, this one is disabled on inspection, Fire phase I, or Fire phase II operation.
<b>DOFRX</b>	Rear Door Open Function Auxiliary Output - Like DOFX but for rear doors.
<b>DOFX</b>	Door Open Function Auxiliary output - The Door Open Function signals the controller to attempt to open the doors. Unlike the standard DOF output on the HC-CTL board, this one is disabled on inspection, Fire phase I, or Fire phase II operation.
<b>DEIS</b>	Front Door Enable Inspection Stop Switch Output - This output will be activated when front door operation is permitted. This output will deactivate if the elevator is on inspection or on TEST mode or the front door stop input has been activated.
<b>DEISR</b>	Rear Door Enable Inspection Stop Switch Output - This output will be activated when rear door operation is permitted. This output will deactivate if the elevator is on inspection or on TEST mode or the rear door stop input has been activated.
<b>DHEND</b>	Door Hold End Output - This output will turn <i>ON</i> five seconds prior to when the Door Hold Timer expires.
<b>DHENDR</b>	Rear Door Hold End Output - This output will turn <i>ON</i> five seconds prior to when the Rear-Door Hold Timer expires.

Table 5.7 Spare Outputs Menu Options

Spare Outputs Menu Options	
<b>DHO</b>	Door Hold Output - This output indicates that the doors are being held open by the <i>door hold input</i> function (the DHLDI input is active, or the timer associated with the door hold function has not yet elapsed).
<b>DISB</b>	Distress Buzzer output - When the ABI (Alarm Bell) input is activated, the DISB output turns on. When the ABI input is deactivated, the DISB output turns off. When the Stop switch is activated, the DISB output turns on. When the Stop switch is returned to normal, the DISB output turns off.
<b>DISL</b>	Distress Light output - When the ABI (Alarm Bell) input is activated, the DISL output turns on. DISL will latch and require momentary activation of the ARST input to clear the DISL output. When the safety string is lost, the DISL output turns on. DISL will latch and require the safety string be restored in addition to momentary activation of the ARST input to clear the DISL output.
<b>DISLX</b>	Auxiliary Distress Light output - When the ABI (Alarm Bell) input is activated, the DISLX output turns on. DISL will latch and require momentary activation of the ARST input to clear the DISLX output. When the safety string is lost, the DISLX output turns on. DISLX will latch and require the safety string be restored in addition to momentary activation of the ARST input to clear the DISLX output. When the elevator is shut down due to some other reason, such as PTI with car calls present, the DISLX output will turn on.
<b>DLOB</b>	Door Left Open Bell Output - Comes on when a call button is pressed and the door has been left open. Used on single button collective and single automatic push button when the hall and car call buttons are connected.
<b>DNO</b>	Down Output (Attendant Service) - This output is used for Attendant Service to indicate that a hall call has been registered below the car and the car has been assigned to answer it. It is normally used to turn on an indicator light to alert the attendant that such hall calls exist.
<b>DNS</b>	Down Sense output - Active while the car travels in the down direction.
<b>DO1, DO2, DO4, DO8, DO16, DO32</b>	Binary coded P.I. outputs for digital P.I. devices.
<b>DOOR ENAB</b>	Door Enable Output - This output will be activated when door operation is permitted. For example if the car is not on Inspection and not on TEST mode.
<b>DSH</b>	Door Time Shortening Output (intermediate) - This output is generated whenever a <i>destination car call</i> button is pressed (this action causes the shortening of the door dwell time if the doors are fully open).
<b>DSHT</b>	Door Time Shortening Front Output (final) - This output reflects the status of the DSHT flag and is generated if either a <i>destination car call</i> button is pressed or if the front door close button is pressed
<b>DSHTR</b>	Door Time Shortening Rear Output (final) - This output reflects the status of the DSHTR flag and is generated if either a <i>destination car call</i> button is pressed, or if the rear door close button is pressed.
<b>ECRN</b>	Emergency Power Car Run Output - This output is a reflection of the emergency car run flag associated with the emergency power logic. When activated, it indicates that the car is being prevented from running by the emergency power operation logic.
<b>EFG</b>	Egress Floor Gong Output - This output will activate for 300 msec. when the car arrives at the "egress" floor and opens the doors in response to a hall or car call (requires that the egress floor be programmed, see <a href="#">"EGRESS FLOOR ARRIVAL GONG? / MAIN EGRESS FLOOR #"</a> on page 5-28). This output is used to activate an audible indicator to inform visually impaired passengers that the elevator has arrived at the main egress floor of the building.

Table 5.7 Spare Outputs Menu Options

Spare Outputs Menu Options	
<b>EMSB</b>	Emergency Medical Service Buzzer Output - This output comes on as soon as the EMS hall switch is activated (EMSIH) and extinguishes when the car reaches the EMS floor (Phase 1 return). EMSB is used to ring an audible signal in the car to alert passengers that the car is being commandeered on EMS service.
<b>EMSIC</b>	Emergency Medical Service Car Indicator Output - This output comes on as soon as the EMS hall switch is activated (EMSH) and will stay on until the car returns to normal service. EMSB is used to activate a visual indicator in the car to alert passengers that the car is on EMS service.
<b>EMSIH</b>	Emergency Medical Service Hall Indicator Output - This output comes on as soon as the EMS hall switch is activated (EMSH) and extinguishes when the in-car switch is activated (EMSC). This output is used for a visual indicator that informs that EMS personnel that the EMS signal has been recognized by the control system.
<b>EP1</b>	Emergency Power Phase 1 Output - This output is activated when Emergency Power is initiated via the EPI input and stays on until all cars have been recalled to the emergency power landing (sequential lowering, the first phase of emergency power).
<b>EP2</b>	Emergency Power Phase 2 Output- This output is activated when the system is in the second phase of emergency power (after recall, the <i>normal running</i> of a car on emergency power generators) and remains activated until commercial power is restored.
<b>EQHL</b>	Earthquake Hydro Latch output - On Hydro controllers this output provides a means to drive an earthquake status indicator.
<b>FIR1</b>	Fire Service Phase I Output - This output is activated during Fire Service Phase I Main and Alternate operations.
<b>FLASH</b>	Flash Output - This output turns ON and OFF at 0.5 second intervals.
<b>FLO</b>	Fan/Light Operation Output - This output is used to turn <i>OFF</i> the fan and the light within the car. The output is usually <i>OFF</i> . It is turned <i>ON</i> after the Fan/Light Timer elapses. The timing starts when the car becomes inactive.
<b>FRC</b>	Fire Service Phase II Output - This output is activated when the car is on Fire Service Phase II. It will remain active until the elevator has completely transitioned out of Fire Service Phase II operation which, depending on the fire code programmed, may not be until the elevator has completed its return to the recall floor and the doors have fully opened after turning the In-car Firefighter's switch to the off position.
<b>FRCT</b>	True Fire Service Phase II Output - Like FRC, this output is activated when the car is on Fire Service Phase II. Unlike FRC, it may remain active after the car is taken off of In-car Firefighter's Service and until the car has recalled to the recall floor and the doors are preparing to open.
<b>FRM</b>	Fire Service Phase I Output - This output is activated when the car is on Main or Alternate Fire Service Phase I. It is deactivated when Fire Service Phase II begins.
<b>FSA</b>	Fire Service Alternate Output - This output is activated when the FRA input is activated by the main fire sensor. It remains activated while the car is on Fire Service Phase I.
<b>FSLCX</b>	Fire Service Light C.O.P. Auxiliary Output - When active, indicates in-car fire service light is active.
<b>FSL LX</b>	Fire Service Lobby Light Auxiliary Output - When active, indicates the lobby fire service light is active.
<b>FSM</b>	Fire Service Main Output - This output is activated by either the fire sensor or switch input for either Fire Service Main Phase I or II.
<b>FSO</b>	Fire Service On Output - This output is activated when the car is on Fire Service Phase I or II and is generally used to activate the visual fire service indicator in the cab.

**Table 5.7 Spare Outputs Menu Options**

<b>Spare Outputs Menu Options</b>	
<b>FSVC</b>	True Fire Service Output - This input is activated when the car is on Fire Service Phase I or II and is used to extinguish the hall position indicators as required by ANSI189 Fire Code.
<b>FWIX</b>	Fire Service Buzzer Auxiliary Output.
<b>FWL</b>	Fire Warning Light Output - This output is used to indicate when the car is on Fire Phase I or II. It will be ON solid except if the machine room or hoistway fire sensors have tripped (FRMR, FRHTW, FRSA, FRSM), in which case it will flash.
<b>GDO1/</b>	<b>2/4/8/16/32</b> Gray Code digital outputs for Gray Code Digital PI devices.
<b>GEDRX</b>	Gong Enable Down Rear Auxiliary Output - Same as GEDX, but for rear doors.
<b>GEDX</b>	Gong Enable Down Auxiliary Output - Unlike the standard GED output on the HC-CTL board, this one is not active on inspection, Fire phase I, or Fire phase II operation.
<b>GEURX</b>	Gong Enable Up Rear Auxiliary Output - Same as GEUX, but for rear doors.
<b>GEUX</b>	Gong Enable Up Auxiliary Output - Unlike the standard GEU output on the HC-CTL board, this one is not active on inspection, Fire phase I, or Fire phase II operation.
<b>H</b>	High Speed output - (informational) Active when the elevator is running at high speed.
<b>HCP</b>	Hall Call Button Pushed Output - This output is active whenever a hall call button is pressed. It is only activated for the amount of time that the button is being pressed.
<b>HCR</b>	Hall Call Reject Output - This output reflects the status of the HCR flag which indicates that a car is not in a position to respond to a hall call, e.g. the car is out of service or its heavy load status is active.
<b>HCRO1 - HCRO8</b>	Hall Card Reader Front Landing Outputs - These outputs are used to indicate that the associated card reader input has been activated thereby allowing the registration of the hall call. Once the call is registered the output will remain active until the call is extinguished. Inputs are available for front landings.
<b>HCRO1R -HCRO8R</b>	Hall Card Reader Rear Landing Outputs - These outputs are used to indicate that the associated card reader input has been activated thereby allowing the registration of the hall call. Once the call is registered the output will remain active until the call is extinguished. Inputs are available for rear landings.
<b>HDNL</b>	High speed down and not leveling. Informational output.
<b>HDSC</b>	Heat Detector Shutdown Complete Output - This output, used for jobs with Detroit Fire Code, is normally active. When the HEATD spare input is activated, the car stops at the next landing and open the doors. Once the doors are fully open (DOL=0), the HDSC output is turned off to indicate that it is okay to shutdown the controller and activate the machine room sprinklers.
<b>HEO</b>	Hospital Emergency Operation output - This output flashes when the car has been selected to respond to a hospital emergency call and will remain flashing until the in-car hospital switch is returned to normal or the time interval that the car must wait for the in-car switch to be turned ON expires (see <a href="#">"HOSPITAL EMERG. OPERATION?"</a> on page 5-50, also see <a href="#">"HOSPITAL EMERG. TIMER"</a> on page 5-27).
<b>HLW</b>	Heavy Load Weigher Output - This output reflects the heavy load status of the elevator. The output is activated when the load in the elevator exceeds the threshold setting (see <a href="#">"Load Weigher Thresholds"</a> on page 5-62) or when the HLI input is activated.
<b>HOSPH2</b>	Hospital Emergency Phase 2 output - This output will remain ON, indicating that the car has arrived at the floor where the hospital call was registered, until the in-car hospital switch is returned to normal or the time interval that the car must wait for the in-car switch to be turned ON expires (see <a href="#">"HOSPITAL EMERG. OPERATION?"</a> on page 5-50, also see <a href="#">"HOSPITAL EMERG. TIMER"</a> on page 5-27).

Table 5.7 Spare Outputs Menu Options

Spare Outputs Menu Options	
<b>HSEL</b>	Hospital Emergency Select output - This output will remain steadily ON, indicating that the car has been selected to answer a hospital call, until the in-car hospital switch is turned ON or the time interval expires (see <a href="#">"HOSPITAL EMERG. TIMER"</a> on page 5-27, also see <a href="#">"HOSPITAL EMERG. OPERATION?"</a> on page 5-50).
<b>HUNL</b>	High speed up and not leveling. Informational output.
<b>HWI</b>	Hospital Emergency Warning Indicator output - This output will remain steadily ON for a car on Independent Service when a hospital emergency call is registered (see <a href="#">"HOSPITAL EMERG. OPERATION?"</a> on page 5-50).
<b>INDFRC</b>	Independent Service/Fire Service Phase 2 Output - This output is used for elevators with either single button collective or single automatic push button operation (see <a href="#">"OPERATION:"</a> on page 5-17). This output is used to disconnect hall calls during Fire Service and Independent Service.
<b>INDO</b>	Independent Service Output. Active when the elevator is running on Independent mode. Typically used to drive an indicator light.
<b>INSP</b>	Inspection. Active when the car is on Inspection operation (any inspection or access mode).
<b>ISRT</b>	In Service and Running Output - This output reflects the car's ability to respond to hall calls (the ISRT status). ISRT is active when the car's status is such that it can answer hall calls.
<b>ISV</b>	In Service Output - This output reflects the status of the in-service flag (ISV) which indicates that the car is in normal passenger mode of operation.
<b>ISVF</b>	Flashing In-Service output - This output functions similar to the standard ISV output, however the ISV output will flash whenever the car times out-of-service (see also ISV).
<b>IUL</b>	In Use Light Output - This output activates when the car is in use, e.g., the car is in motion or the doors are open.
<b>LLW</b>	Light Load Weigher Output - This output reflects the light load status of the elevator. The output is activated when the load in the elevator is less than the threshold set for light load anti-nuisance (see <a href="#">"Load Weigher Thresholds"</a> on page 5-62) or when the LLI input is activated (see <a href="#">"LIGHT LOAD WEIGHING? / LIGHT LOAD CAR CALL LIMIT"</a> on page 5-48).
<b>MISV</b>	Mechanically In Service Output - This output is normally active when the car is running normally, but is turned off when the car appears to be mechanically out of service (as indicated by the Safety String (SAF) and Motor Limit Timer (MLT)).
<b>MLT</b>	Motor Limit Timer Elapsed Output - This output is activated in two instances: when the Motor Limit Timer Elapses, and when the EXMLT input is active (Hydro controller).
<b>MLTP</b>	Motor Limit Timer Elapsed Output (not activated by EXMLT) - Activated when the Motor Limit Timer has elapsed. Not activated by EXMLT.
<b>NBZX</b>	Nudging Buzzer Auxiliary output. Unlike the standard NBZ output on the HC-CTL board, this one is not active on inspection, Fire phase I, or Fire phase II operation.
<b>NCD</b>	Car Not Done with Emergency Power Return Output - This output is deactivated when the car has finished returning on emergency power or when it has been determined that the car cannot lower (see <a href="#">"EMERGENCY POWER OPERATION?/EMERGENCY POWER RETURN FLOOR"</a> on page 5-48).
<b>NDGRX</b>	Rear Door Nudging Auxiliary Output - Same as NDGX, but for rear doors.
<b>NDGX</b>	Door Nudging Auxiliary Output - The Door Nudging output signals the controller to attempt to close the doors at reduced torque. Unlike the standard N1 output on the HC-CTL board, this one is not active on inspection, Fire phase I, or Fire phase II operation.

**Table 5.7 Spare Outputs Menu Options**

Spare Outputs Menu Options	
<b>OFR</b>	One Floor Run Output - This output is generated when the car initiates a run and remains active until the car encounters the first door zone in its movement (the output is active while traversing the first floor height in its direction of travel).
<b>OFRP</b> ASME A17.1-2000	One Floor Run Programmable Output - This output will be active while making one-floor runs between adjacent floors designated in the Extra Features Menu (see <a href="#">"OFRP BETWEEN FLRS"</a> on page 5-52).
<b>OLW</b>	Overloaded Car Threshold Output - This output is activated when the threshold value considered to be unsafe to move the elevator is reached (see <a href="#">"Load Weigher Thresholds"</a> on page 5-62) or OVL input. When this threshold is exceeded, the car will remain at the floor with doors open. A typical application that requires such a feature will use some type of visual and/or audible indicator to alert elevator passengers that the car is overloaded (this is the typical reason for using this output). This operation is overridden by Fire Service Phase II operation.
<b>PFGX</b>	Passing Floor Gong Auxiliary Output. Unlike the standard PFG output on the HC-CTL board, this one is not active on inspection, Fire phase I, or Fire phase II operation.
<b>PH1</b>	Fire Service Phase I Return Complete Output - The PH1 output indicates that the car has successfully completed the Fire Service Phase I recall function (the car is at the fire recall floor with its doors open). This output is most often used as a signal that it is okay to activate the machine room sprinklers.
<b>PI1 - PI8</b>	Position Indicator outputs (discrete). One wire per floor.
<b>PRIFLG</b>	Priority Service Output - This is to indicate, to the emergency power overlay, that this car is on emergency/priority service and should be selected to run. Priority operation includes: Hospital Service, EMT Service, Fire Service Phase II, Earthquake Service and Test Mode.
<b>SAFO</b>	Safety output - This output activates when the car safety string opens.
<b>SEC</b>	Security Code Incorrect Output - When the building's elevator security is on, this output will turn on for five seconds when an incorrect security code is entered.
<b>SIMPO</b>	Simplex Output - This output comes on when the SIMP input is activated or when Simplex Operation is chosen through KCE (if available). It is used to activate a relay(s) to separate the two hoistway risers.
<b>SYNC</b>	Synchronization Output - (PHC controllers) - This output is used to bypass the down normal limit switch to allow the car to be moved to the buffer at leveling speed. The computer generates the down direction output (DNDO) to move the car in the down direction. This output will be generated for 10 seconds to allow the car to move completely onto the buffer. Once this time elapses, the computer will generate the up direction output to move the car in the up direction at leveling speed, until the car reaches the bottom landing dead zone. At the time up direction travel is initiated, the SYNC output is turned <i>OFF</i> , removing the bypass around the down normal limit switch.
<b>TESTSWO</b>	Test switch output - activates when the car is put in Test mode.
<b>TOS</b>	Timed Out of Service Output - This output is a reflection of the Timed Out of Service flag. The TOS flag is set if the car does not move within a certain amount of time, with either SUA or SDA active.
<b>UPO</b>	Up Output (Attendant Service) - This output comes on to indicate that a hall call has been registered above the car and the car has been assigned to answer it. UPO is normally used to run an indicator light to alert the attendant that such hall calls exist.
<b>PI1 - PI8</b>	Position Indicator outputs (discrete). One wire per floor.
<b>UPS</b>	Up Sense output - Active while the car travels in the up direction.



Table 5.7 Spare Outputs Menu Options

Spare Outputs Menu Options	
<b>WLDI</b>	Wild Operation Indication Output - This output is generated when the car is in emergency dispatch mode of operation, e.g., if the hall call bus fuse is blown and <i>emergency dispatching</i> is activated.
<b>XPI 1 - XPI 7</b>	Auxiliary Position Indicators 1 through 7 Outputs - These outputs behave identically to the standard PI1 - PI7 outputs except that the XPI1 - XPI7 outputs are disabled on Inspection or during Fire Service Phase I and II.
<b>XSDA</b>	Auxiliary Supervisory Down Arrow Output - This output behaves identically to the standard SDA output except that the XSDA output is disabled on Inspection and during Fire Service Phase I and II.
<b>XSUA</b>	Auxiliary Supervisory Up Arrow Output - This output behaves identically to the standard SUA output except that the XSUA output is disabled on Inspection and during Fire Service Phase I and II.
<b>ZADJ</b>	Zero Adjust Output - This output is used to cause the analog load weigher to perform its zero adjust procedure. The output is generated once every 31 hours or whenever the car is idle at the bottom floor for 30 seconds.

## Extra Features Menu Options

**PI OUTPUT TYPE** Choose either 1 WIRE PER FLOOR, BINARY BASE 1, BINARY BASE 0, GRAY CODE 1, or GRAY CODE 0 depending on the inputs required by the position indicator and whether the floor count begins with a zero value or a one value.

**FLOOR ENCODING INPUTS?** If this option is selected, whenever the car is in a door zone the computer checks the floor code inputs and corrects the P.I., if necessary. The code inputs are provided by the landing system (refer to the Job Prints). Refer to R4, R3, R2 (see [“Spare Inputs Menu Options” on page 5-29](#)).

**ENCODE ALL FLOORS?** This option is only available when the Floor Encoding option is programmed to YES. This option indicates at what landing the Absolute Floor Encoding values begin. When set to YES, then every landing must have AFE code values, including the terminal landings. When set to NO, then only intermediate landings must have AFE code values.

**EMERGENCY POWER OPERATION?/EMERGENCY POWER RETURN FLOOR** If this option is selected, the controller will put the elevator into Emergency Power Operation when the controller receives the Emergency Power Input (EPI) signal. During Phase 1 of Emergency Power Operation, the car will be moved to the emergency power return floor. In a duplex controller, each car will be moved to the emergency power return floor, one at a time.

During Phase 2 of Emergency Power Operation, if the car's Emergency Power Run (EPRUN) input is activated, the car will run normally. Otherwise, the car will remain at the emergency power return floor and will not respond to any calls.

For a simplex controller, the car's EPRUN input is sometimes connected to a switch, so that the input can be turned *ON* and *OFF*. For a duplex controller, both cars' EPRUN inputs are usually connected to a Run Selection switch. The position of this switch determines which car will run during Phase 2 of Emergency Power Operation.

Often there is an AUTO position on the Run Selection switch connected to the AUTO input on both controllers in a duplex. If the AUTO input is activated, then one car will be automatically selected to run during Phase 2 of Emergency Power Operation. For example: If one car happens to be out of service when the operation begins, the other car will be automatically selected to run.

If the Emergency Power option is selected, then the appropriate spare inputs should be selected also (see [“Spare Inputs Menu Options” on page 5-29](#)).

**LIGHT LOAD WEIGHING? / LIGHT LOAD CAR CALL LIMIT** This option is only used when the Light Load Weigher Input is activated (see [“Spare Inputs Menu Options” on page 5-29](#), LLI spare input). To program this option, activate the LLI input. Then, set LIGHT LOAD WEIGHING? to *NO* or press *S* to select the maximum number of car calls registered before all the car calls are canceled. If *S* is pressed, the display will read LIGHT LOAD CAR CALL LIMIT. Press *S* until the desired number is displayed.

**PHOTO EYE ANTI-NUISANCE? / CONSEC STOPS W/O PHE LIMIT** When this option is *ON*, the car calls will cancel if the Photo Eye input has not been activated after a programmed number of consecutive stops. The number of consecutive stops must be pro-

grammed before the car calls will cancel. To program this option, set PHOTO EYE ANTI-NUISANCE? to *NO* or press *S* to select the number of consecutive stops. If *S* is pressed, the display will read CONSEC STOPS W/O PHE LIMIT. Press *S* until the desired number is displayed.

**CC CARD READER SECURITY?** *YES/NO* - This option will enable card reader security through a dedicated HC-UIO board. The card reader spare inputs must NOT be used when this option is set to "YES". This option requires that a dedicated HC-UIO board be used for it to function properly.

**WPIx LANDING? (x = A thru H)** Wandering Patient Security (Bracelet Security)  
When a WPIx input is activated, hall calls to the landing and side associated with that input are disabled. If the elevator is already at that landing with doors open, it will be shut down and prevented from leaving that landing. Set the landing number and the side (Front, Rear or Both) to be disabled when the corresponding spare input (WPIA thru WPIH) is activated.

**ALLOW CAR CALLS ON WP SEC.?** *YES/NO* - Wandering Patient Security (Bracelet Security) If set to Yes, car calls to landings with active WPIx inputs are allowed, otherwise car calls to those landings shall be disabled.

**CANCEL BOTH HALL (U/D) CALLS** *YES/NO* - If set to NO, when servicing a hall call, only the call in the direction of travel is canceled. If set to YES, when servicing a hall call, calls in both up and down directions are canceled.

**RETAIN CALLS ON CTL/CTF?** *YES/NO* - If set to No, when a Car-to-Lobby or Car-to-Floor function is activated, latched car calls are serviced and then the car moves to the return or lobby floor. If set to Yes, when CTL or CTF is activated, the car moves to the return or lobby floor immediately, but any un-serviced car calls remain latched. When CTL/CTF is dropped, the retained calls are serviced.

**AUTOMATIC FLOOR STOP OPTION? / AUTOMATIC STOP FLOOR #?**  
When this option is set to a specific floor number, the car will automatically stop at that floor if its travel would cause it to pass that floor.

**CC CANCEL W/DIR REVERSAL?** This option will cause all of the previously registered car calls to be canceled whenever a direction reversal is detected.

**CANCEL CAR CALLS BEHIND CAR?** If this option is set to *YES* and the car has a direction arrow (SUA/SDA), no car calls can be registered behind the car's current position. For example: If a car is at the fifth floor moving down, no car calls can be registered from sixth floor and above.

**CE ELECTRONICS BOARD?** *REV 1/REV 2* - This option allows information such as position and arrival gong outputs to be provided for a CE electronics device. This option is to be used with the CE Electronics Interface board (Rev 1 and Rev 2) which provides a 3-wire serial interface to CE electronic fixtures.

**MASSACHUSETTS EMS SERVICE? / EMS SERVICE FLOOR #** This option is provided in the state of Massachusetts only. This option is key-operated and provides immediate car service for Massachusetts Emergency Medical Service personnel.

**MASTER SOFTWARE KEY** This option is a board-level control of the security system. Standard Security is initiated by the Master Software Key. There are three possible settings for the Master Software Key: ACTIVATED, ENABLED or DEACTIVATED.

- If set to ACTIVATED, Security is initiated.
- If set to ENABLED, Security is initiated only if the Building Security Input (BSI) is turned *On*.
- If set to DEACTIVATED, Security is deactivated regardless of the status of the BSI input.

**PI TURNED OFF IF NO DEMAND?** Setting this option to *YES* will allow the PI outputs to turn *OFF* if the car has been inactive for an adjustable time (from 1 to 10 minutes) as determined by the fan/light timer. [Please refer to “FAN/LIGHT OUTPUT TIMER” on page 5-27.](#)

**HOSPITAL EMERG. OPERATION?** This option calls any eligible in-service elevator to any floor on an emergency basis. If this installation has Hospital Emergency Service Operation, a hospital emergency call switch will be installed at each floor where this service is desired.

When the hospital emergency momentary call switch is activated at any floor, the hospital emergency call registered light will illuminate at that floor only, and the nearest available elevator will respond to the hospital emergency call. All car calls within the selected car will be canceled and any landing calls which had previously been assigned to that car will be transferred to the other car. If the selected car is traveling away from the hospital emergency call, it will slow down and stop at the nearest floor without opening the doors, reverse direction, and proceed nonstop to the hospital emergency floor. If the selected car is traveling toward the hospital emergency floor, it shall proceed nonstop to that floor. At the time of selection, if the car happens to slow down for a stop, it will stop without opening the doors and then start immediately toward the hospital emergency floor.

When the car reaches the hospital emergency floor, it will remain with doors open for a pre-determined time interval. After this interval has expired, if the car has not been placed on in-car Hospital Emergency Service Operation, the car will automatically return to normal service.

A hospital emergency key switch will be located in each car operating station for selecting in-car Hospital Emergency Service Operation. Upon activation of the key switch, the car will be ready to accept a call for any floor, and after the doors are closed, will proceed nonstop to that floor. Returning the key switch to the normal position will restore the car to normal service.

Either car selected to respond to a hospital emergency call will be removed from automatic service and will accept no additional calls, emergency or otherwise, until it completes the initial hospital emergency function. If both cars are out of service and unable to answer an emergency call, the hospital emergency call registered light will not illuminate.

Four outputs are available on the first HC-UIO board used for the hospital emergency service calls. Hospital Emergency Operation (HEO) will flash once the car has been selected to respond to a hospital emergency call and will remain flashing until the in-car hospital switch is returned to normal or the time interval that the car must wait for the in-car switch to be turned *ON* expires. Hospital Emergency Warning Indicator (HWI) will remain steadily *ON* for a car on Independent Service when the hospital call is registered. Hospital Emergency Select (HSEL) will remain steadily *ON*, indicating that the car has been selected to answer a hospital call, until

the in-car hospital switch is turned *ON* or the time interval expires. Hospital Emergency Phase 2 (HOSPH2) will remain *ON*, indicating that the car has arrived at the floor where the hospital call was registered, until the in-car hospital switch is returned to normal or the time interval that the car must wait for the in-car switch to be turned *ON* expires.

If you do not have Hospital Emergency Service Operation, set this option to *NO* by pressing the *S* push button. Then, press the *N* push button to exit this option.

If you have Hospital Emergency Service Operation, set this option to *YES* by pressing the *S* push button. Press the *N* push button to continue. The following display will appear:

If you want Hospital Emergency Service to this landing, then set this option to *YES* by pressing the *S* push button (press *S* again to set the option to *NO*). Press the '+' push button to scroll through the available landings. Press the *N* push button to continue. If this car has rear doors, then the following will be displayed:

Press the '+' push button to scroll through the available landings. The computer will continue to present these options for each floor, up to the top floor. Press the *N* push button to exit the Hospital Emergency Service option.

**FIRE BYPASSES HOSPITAL?** Used if the HOSPITAL EMERG. OPERATION and FIRE SERVICE OPERATION options are set to YES. Set this option to YES if Hospital Service is used for VIP, Priority or Commandeering Service. Set this option to NO if Hospital Service is *truly* used for Hospital Service, also known as Code Blue.

**HIGH SPEED DELAY AFTER RUN?** Setting this option will insert a fixed delay (3 seconds) between the completion of a run and the initiation of the next run. This option should be used in applications in which an immediate “stop/start” is undesirable. Under most “normal” circumstances, the initiation of a run is delayed by the time required for the door operation. In some cases, however, the car may stop and start immediately in the absence of a door operation (example: a direction reversal upon being assigned a hall call while the car is parking).

**SABBATH OPERATION** If you do not have Sabbath Operation, set this option to *NO* by pressing the *S* Push button. Then, press the *N* push button to exit this option.

If you have Sabbath Operation, set this option to *YES* by pressing the *S* push button. Press the *N* push button to continue. The following display will appear:

“FRONT UP STOP AT FLOOR 1?”

If you want to set the car to stop at this floor while traveling or initiating travel in the UP direction, press the *S* push button to select *YES* (press *S* again to set this option back to *NO*). Press the + push button to increment the floor value to the next landing. Continue until all of the desired front UP stops are set to *YES*.

Press the *N* push button to proceed to the next eligibility map. If there are no walk through doors on this controller, then the rear eligibility maps will not display. In order, the next eligibility maps are as follows:

"REAR UP STOP AT FLOOR 1?"  
"FRONT DOWN STOP AT FLOOR 2?"  
"REAR DOWN STOP AT FLOOR 2?"

Remember that the + push button increments the floor value to the next landing. And that the N push button will proceed to the next eligibility map.

**LEVELING SENSOR ENABLED/DISABLED** If this option is set to disabled, the LEVELING SENSOR FAILED - ON (OFF) POSITION and DOOR ZONE SENSOR FAILURE - ON (OFF) POSITION errors will not be generated.

**KCE ENABLE / DISABLE** The KCE Enable is set to ON when ENABLE is selected or OFF when DISABLE is selected from the menu display.

**ANALOG LOAD WEIGHER?** This option enables the analog load weigher logic and selects the type of learn operation to be performed, depending on the type of load weigher installed.

**IND. BYPASS SECURITY? YES / NO** This option determines if Elevator Security is bypassed when the car is on Independent Service (available only when Security is enabled).

**ATS. BYPASS SECURITY? YES / NO** This option determines if Elevator Security should be bypassed when the car is on Attendant Service (available only when Security and Attendant Service are enabled).

**CAR TO FLOOR RETURN FLOOR** This option determines the floor to which the car will be returned when the CAR TO FLOOR input is activated (see CTF in Spare Inputs Menu Options).

**SCROLLING SPEED** (NORMAL/FAST/SLOW) Menu options which are too long to be fully displayed on the LCD display are scrolled. This option determines the scrolling speed.

**LOW OIL SWITCH CONTACT (N.O. / N.C.)** This option should be set according to the type of low oil switch used (normally open or normally closed).

**OFRP BETWEEN FLRS** Sets the floors between which the OFRP output will be triggered. The One Floor Run Programmable output will then be on while making **one-floor runs** between designated floors.

**ENABLE FRONT DOB ON SECURITY?** YES/NO - YES = the front door open button will be enabled for all landings including secure landings. NO = the front door open button will be disabled at secure landings once the doors have closed.

**ENABLE REAR DOB ON SECURITY?** YES/NO - YES = the rear door open button will be enabled for all landings including secure landings. NO = the rear door open button will be disabled at secure landings once the doors have closed.

**FLR COUNT BELOW FLOOD LEVEL?** PITFLD spare input required. Indicates the number of floors below flood level and thereby sets the flood level. The set number of floors from the bottom of the hoistway will not be serviced when the PITFLD input is active.

**DISABLE TOP FLRS ON PITFLD**     *YES/NO* - PITFLD spare input required. Prevents the elevator from servicing floors at the top of the hoistway (determined by FLR COUNT BELOW FLOOD LEVEL) when the PITFLD input is active, thereby preventing the counter-weight from going into the water.

**RETAIN CALLS ON CTL / CTF?**     *NO*: If Car To Lobby or Car To Floor are activated, the car will first service registered car calls then move to the recall floor. Hall calls are canceled.  
*YES*: If Car To Lobby or Car To Floor are activated, the car will first service registered car calls then move to the recall floor. Hall calls are retained and served after the CTL input is deactivated.

## Additional Car Options Menu

**HOISTWAY ACCESS? (YES/NO)**     Set to YES if job has Hoistway Access operation.

**TOP ACCESS? (F/R)**     Set to the riser in which the hall access switch is located.

**BOTTOM ACCESS? (F/R)**     Set to the riser in which the hall access switch is located.

**NUMBER OF MOTOR STARTERS**     (1-3) - Indicates the total number of starters for this car.

**MIN. NUMBER OF MOTORS**     (1-3) - Set the minimum number of starters required to run. This option is only available for multi-starter controllers.

**SOFT-STOP TIMER**     (NONE / 0.1-1.0 sec) - The soft-stop timer will cause the pump to continue to operate for the programmed amount of time after the elevator has stopped to allow the valves to fully close.

**STARTER #1 TYPE:**     (WYE-DELTA / ACROSS THE LINE / SOLID STATE) - Select the appropriate type of starter. Applicable to starter #1.

**STARTER #2 TYPE:**     (WYE-DELTA / ACROSS THE LINE / SOLID STATE / NONE) - Select the appropriate type of starter. Applicable to starter #2.

**STARTER #3 TYPE:**     (WYE-DELTA / ACROSS THE LINE / SOLID STATE / NONE) - Select the appropriate type of starter. Applicable to starter #3.

**Y-D TRANSFER TIMER**     (1.0-8.0 sec) - Represent the amount of time that the motor will run with a Wye contactor before switching to the Delta contactor. Set this option only for starters with WYE-DELTA configuration.

**UP TO SPEED TIMER**     (1.0-8.0 sec) - Represent the amount of time that the controller will wait to allow the motor to accelerate to nominal speed. Set this option only for starters with ACROSS THE LINE or SOLID STATE configuration.

**Y-D OPEN TRANSN. TIMER**     (50-500 msec) - Represent the time delay in picking the Delta contactor after the dropping of the Wye contactor. Set this option only for starters with WYE-DELTA configuration.

**M CONTACTOR INSTALLED?** (YES/NO) - Set this option to YES only for starters with M Contactors. Option not available for SOLID STATE starters.

**STARTER CONFIG:** (SEQUENTIAL / SIMULTANEOUS) - This option is only available for multi-starter Hydraulic systems. If the SEQUENTIAL option is set the starters will start in a sequential fashion to reduce inrush current. If the SIMULTANEOUS option is set then all starters in the system will start at the same time.

**VALVE TYPE:** (STANDARD / PILOT RELAYS / TKE / DOVER) - This option indicates the type of valve used for this installation.

**SPEED > 150 FPM?** (YES/NO) - This option must be set to YES on ASME A17.1-2000 code compliant hydraulic elevators with speeds exceeding 150 FPM. When on Inspection operation, running at high speed is prevented by disabling the FUD output.

**DOOR POSITION MONITOR:** (NONE/FRONT/REAR/BOTH) - This parameter indicates the use of a door position monitor on front, rear or both doors (DPM / DPMR inputs) in order to enable the door position monitor logic.

**FRONT DOOR CLOSE LIMIT?** (NONE/DCL/GS+DCAB) - Set to the front door close limit signals used by this car. (DCL for door close limit switch. GS and DCAB for gate switch and door closed bottom access. None.)

**REAR DOOR CLOSE LIMIT?** (NONE/DCL/GS+DCAB) - Set to the rear door close limit signals used by this car. (DCL for door close limit switch. GS and DCAB for gate switch and door closed bottom access. None.)

## Timed Features

This menu allows you to select and program features that will be executed based on a time schedule.

**SYNC. OP. DAYS** (EVERYDAY, MON, TUE, WED, THUR, FRI, SAT, SUN) - Use **S** and **+** pushbuttons to select (YES/NO) the days(s) on which the Synchronization operation is to be performed (use in lieu of SYNCI input, see [“SYNCI” on page 5-37](#)).

**SYNC. STARTING TIME** (24 hour format / 30 minute increments) - Set the time at which the Synchronization operation is to begin (see [“SYNC. OP. DELAY TIMER” on page 5-28](#)).



## F2: External Memory Mode

External Memory mode can be used to view memory addresses in the external RAM on the HC-MPU board. The external memory address is denoted by the letters DA (Data Address). The ability to view the external memory can also be helpful for diagnosing and troubleshooting the elevator system. The Computer External Memory Chart (page 5-57) shows the meaning of the data digits at different addresses.

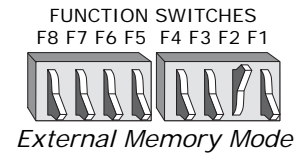

### Getting Into External Memory Mode

External Memory mode is initiated by placing the *F2* switch in the up position. The following is a description of the LCD display format and the function of the N, S, +, and - push buttons during External Memory mode.

#### Function of N Push Button

The *N* push button allows for the advancement of the computer memory address, which is displayed on the second line of the LCD display. For example, for this display, pressing the *N* push button once (hold it for 1-2 seconds) will cause the 1 in the address 1234 to begin blinking. By continuing to press the *N* push button, the 2 in the address 1234 will begin to blink. The cycle will continue while the *N* push button is being pressed. Once the digit needed to be changed is blinking, the address can then be modified.

The data (8 digits) that correspond to the external memory address is displayed to the right of the address. This data display will change as the memory address changes.

#### Function of S Push Button

The *S* push button ends the ability to change the address by stopping the digit from blinking. If the *S* push button is not pressed, the selected digit will stop blinking automatically after 20 seconds.

#### Function of + Push Button

The + push button modifies the digit of the computer memory address selected by the *N* push button. If the + button is pressed, the selected digit is incremented by one. The data display will also change as the address changes. For example, if the 2 of the address 1234 is blinking, pressing the + push button once will change the address from 1234 to 1334. Pressing the + push button several more times will change the address to 1434, 1534, 1634, etc., up to 1F34 and then back to 1034.

#### Function of – Push Button

The – push button modifies the digit of the computer memory address selected by the *N* push button. If the – push button is pressed, the selected digit is decremented by one. The data display will also change as the address changes. For example: If the 2 in the address 1234 is blinking, pressing the – push button once will change the address from 1234 to 1134. Pressing the – push button several more times will change the address to 1034, 1F34, 1E34, etc.

## Troubleshooting Using External Memory Mode

By using the computer's External Memory mode, it is possible to find out if the controller is receiving call signals correctly, as well as HC-UIO board input and output signals.

The following example illustrates how to use the Computer External Memory Chart to check a signal in the computer's external memory.

Example problem: The DHLD (Door Hold Open Switch) input will not cause the doors to stay open. DHLD is programmed for the Spare 5 input.

1. Find SP5 in the Computer External Memory Chart ([page 5-57](#)). Notice that the Address of SP5 is 02AF and the Position is 4.
2. Look up the signal on the computer. Change the address on the display to Address 02AF (see "[F2: External Memory Mode](#)" on [page 5-55](#)). Look at data bit number 4 (from the right), which is underlined in the following display:

This digit represents the computer's interpretation of the Spare 5 input signal. If the digit is 1, the computer thinks that the SP5 signal is *ON*. If the digit is 0, the computer thinks that the SP5 signal is off.

This information can be used to determine the source of the problem. If the Spare 5 input is programmed for the DHLD (Door Hold) input and the doors are not staying open, the diagnostic display will show that the SP5 input is off. If this is the case, checking the voltage on the SP5 terminal will show whether the problem is inside or outside the controller.

Table 5.8 Computer External Memory Chart

HALL CALLS							CAR CALLS	
ADD	8	7	6	5	4	3	2	1
0140:	601R/UC1R	601/UC1					101R/CC1R	101/CC1
0141:	602R/UC2R	602/UC2	502R/DC2R	502/DC2			102R/CC2R	102/CC2
0142:	603R/UC3R	603/UC3	503R/DC3R	503/DC3			103R/CC3R	103/CC3
0143:	604R/UC4R	604/UC4	504R/DC4R	504/DC4			104R/CC4R	104/CC4
0144:	605R/UC5R	605/UC5	505R/DC5R	505/DC5			105R/CC5R	105/CC5
0145:	606R/UC6R	606/UC6	506R/DC6R	506/DC6			106R/CC6R	106/CC6
0146:	607R/UC7R	607/UC7	507R/DC7R	507/DC7			107R/CC7R	107/CC7
0147:	608R/UC8R	608/UC8	508R/DC8R	508/DC8			108R/CC8R	108/CC8
0148:	609R/UC9R	609/UC9	509R/DC9R	509/DC9			109R/CC9R	109/CC9
0149:	610R/UC10R	610/UC10	510R/DC10R	510/DC10			110R/CC10R	110/CC10
014A:	611R/UC11R	611/UC11	511R/DC11R	511/DC11			111R/CC11R	111/CC11
014B:	612R/UC12R	612/UC12	512R/DC12R	512/DC12			112R/CC12R	112/CC12
014C:	613R/UC13R	613/UC13	513R/DC13R	513/DC13			113R/CC13R	113/CC13
014D:	614R/UC14R	614/UC14	514R/DC14R	514/DC14			114R/CC14R	114/CC14
014E:	615R/UC15R	615/UC15	515R/DC15R	515/DC15			115R/CC15R	115/CC15
014F:	616R/UC16R	616/UC16	516R/DC16R	516/DC16			116R/CC16R	116/CC16
0150:	617R/UC17R	617/UC17	517R/DC17R	517/DC17			117R/CC17R	117/CC17
0151:	618R/UC18R	618/UC18	518R/DC18R	518/DC18			118R/CC18R	118/CC18
0152:	619R/UC19R	619/UC19	519R/DC19R	519/DC19			119R/CC19R	119/CC19
0153:	620R/UC20R	620/UC20	520R/DC20R	520/DC20			120R/CC20R	120/CC20
0154:	621R/UC21R	621/UC21	521R/DC21R	521/DC21			121R/CC21R	121/CC21
0155:	622R/UC22R	622/UC22	522R/DC22R	522/DC22			122R/CC22R	122/CC22
0156:	623R/UC23R	623/UC23	523R/DC23R	523/DC23			123R/CC23R	123/CC23
0157:	624R/UC24R	624/UC24	524R/DC24R	524/DC24			124R/CC24R	124/CC24
0158:	625R/UC25R	625/UC25	525R/DC25R	525/DC25			125R/CC25R	125/CC25
0159:	626R/UC26R	626/UC26	526R/DC26R	526/DC26			126R/CC26R	126/CC26
015A:	627R/UC27R	627/UC27	527R/DC27R	527/DC27			127R/CC27R	127/CC27
015B:	628R/UC28R	628/UC28	528R/DC28R	528DC28			128R/CC28R	128/CC28
015C:	629R/UC29R	629/UC29	529R/DC29R	529/DC29			129R/CC29R	129/CC29
015D:	630R/UC30R	630/UC30	530R/DC30R	530/DC30			130R/CC30R	130/CC30
015E:	631R/UC31R	631/UC31	531R/DC31R	531/DC31			131R/CC31R	131/CC31
015F:			532R/DC32R	532/DC32			132R/CC32R	132/CC32
<b>SPARE INPUTS*</b>								
ADD	8	7	6	5	4	3	2	1
02AF:	SP8	SP7	SP6	SP5	SP4	SP3	SP2	SP1
02B0:	SP16	SP15	SP14	SP13	SP12	SP11	SP10	SP9
02B1:	SP24	SP23	SP22	SP21	SP20	SP19	SP18	SP17
02B2:	SP32	SP31	SP30	SP29	SP28	SP27	SP26	SP25
02B3:	SP40	SP39	SP38	SP37	SP36	SP35	SP34	SP33
02B4:	SP48	SP47	SP46	SP45	SP44	SP43	SP42	SP41
02B5:							SP50	SP49
* The first 10 spare inputs are located on the HC-CTL board. The remaining spare inputs are located on HC-UIO boards numbered 32 through 36 (8 per board).								
<b>SPARE OUTPUTS **</b>								
ADD	8	7	6	5	4	3	2	1
02EF:	OUT4	OUT3	OUT2	OUT1				
02F0:	OUT12	OUT11	OUT10	OUT9	OUT8	OUT7	OUT6	OUT5
02F1:	OUT20	OUT19	OUT18	OUT17	OUT16	OUT15	OUT14	OUT13
02F2:	OUT28	OUT27	OUT26	OUT25	OUT24	OUT23	OUT22	OUT21
02F3:	OUT36	OUT35	OUT34	OUT33	OUT32	OUT31	OUT30	OUT29
02F4:	OUT44	OUT43	OUT42	OUT41	OUT40	OUT39	OUT38	OUT37
** The first four spare outputs are located on the HC-CTL board. The remaining spare outputs are located on HC-UIO boards numbered 32 through 35 (8 per board).								



**Table 5.9 Hospital Call and Eligibility Memory Chart**

HOSPITAL CALL ELIGIBILITY					HOSPITAL CALLS				
	OTHER CAR		THIS CAR		ASSIGNED HOSPITAL CALLS		REGISTERED HOSPITAL CALLS		
	REAR	FRONT	REAR	FRONT	REAR	FRONT	REAR	FRONT	
ADD	8	7	6	5	4	3	2	1	
0240:							ECR1	EC1	Floor # 1
0241:							ECR2	EC2	Floor # 2
0242:							ECR3	EC3	Floor # 3
0243:							ECR4	EC4	Floor # 4
0244:							ECR5	EC5	Floor # 5
0245:							ECR6	EC6	Floor # 6
0246:							ECR7	EC7	Floor # 7
0247:							ECR8	EC8	Floor # 8
0248:							ECR9	EC9	Floor # 9
0249:							ECR10	EC10	Floor # 10
024A:							ECR11	EC11	Floor # 11
024B:							ECR12	EC12	Floor # 12
024C:							ECR13	EC13	Floor # 13
024D:							ECR14	EC14	Floor # 14
024E:							ECR15	EC15	Floor # 15
024F:							ECR16	EC16	Floor # 16
0250:							ECR17	EC17	Floor # 17
0251:							ECR18	EC18	Floor # 18
0252:							ECR19	EC19	Floor # 19
0253:							ECR20	EC20	Floor # 20
0254:							ECR21	EC21	Floor # 21
0255:							ECR22	EC22	Floor # 22
0256:							ECR23	EC23	Floor # 23
0257:							ECR24	EC24	Floor # 24
0258:							ECR25	EC25	Floor # 25
0259:							ECR26	EC26	Floor # 26
025A:							ECR27	EC27	Floor # 27
025B:							ECR28	EC28	Floor # 28
025C:							ECR29	EC29	Floor # 29
025D:							ECR30	EC30	Floor # 30
025E:							ECR31	EC31	Floor # 31
025F:							ECR32	EC32	Floor # 32

**Legend for Table 5.8:**

	Registered hospital calls for the floor opening. 1 = call is registered 0 = call is not registered
	Assigned hospital calls for the floor opening 1 = Call is assigned 0 = Call is not assigned
	The car is eligible for hospital Emergency Service Operation for the floor opening. 1 = Hospital emergency call can be entered for the floor opening 0 = Hospital emergency call cannot be entered for the floor opening

## F3: System Mode

System mode allows the user to change certain system-wide options that do not require the car to be on Inspection. To enter System mode, move the **F3** switch to the up position. Press the **N** push button to select the desired System Mode item.

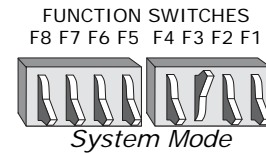

- Building Security Menu (see [page 5-59](#))
- Passcode Request Menu (see [page 5-61](#))
- Load Weigher Thresholds (see [page 5-62](#))
- Analog Load Weigher Learn Function (see [page 5-62](#))
- Controller System Menu (see [page 5-65](#))
- Messages and Floor Labels (see [page 5-66](#))

### Building Security Menu

Elevator Security is typically used to prevent access to specific floors via the elevators, or to limit access to passengers with a valid security code. MCE's elevator security options include Basic Security and Basic Security with Remote Monitoring. Basic Security provides a means to prevent registration of unauthorized car calls. Basic Security with Remote Monitoring provides a means to prevent registration of unauthorized car calls and/or hall calls and additional programming options are available via the remote monitoring. Refer to MCE's iMonitor User's Guide, part # 42-02-S025 for additional information and instructions for using the remote monitoring software. The Appendix *Elevator Security Information and Operation* in this manual provides instructions for passengers who will be using the elevator while Security is ON. For both Basic Security and Basic Security with Remote Monitoring, the security codes for each floor are programmed as described below.

5

The Security code for each floor may consist of one to eight characters where each character is one of the floor buttons found in the elevator car. With Basic Security, any floor with a programmed security code is a secured floor when Security is ON. Basic Security is turned ON or OFF by the Building Security Input (BSI) (see ["Spare Inputs Menu Options" on page 5-29](#)) in combination with the Master Software Key parameter in the Extra Features Menu (see ["MASTER SOFTWARE KEY" on page 5-50](#)). There are 3 possible settings for the Master Software Key: ACTIVATED, ENABLED, and DEACTIVATED:

- If set to ACTIVATED, Security is ON.
- If set to ENABLED, Security is ON when the BSI input is turned ON.
- If set to DEACTIVATED, Security is OFF regardless of the status of the BSI input.

To find the BSI input, refer to the job prints. When Security is ON, all car calls are screened by the computer and become registered only if 1) the call is not to a secured floor, or 2) the call is to a secured floor and its security code is correctly entered within 10 seconds.

#### Viewing the Building Security Menu

1. Place the **F3** switch in the up position (with all other switches in the down position). The following display appears:
2. Press the **N** pushbutton. The following display appears:

```
SYSTEM MODE
PRESS N TO BEGIN
```

```
* BUILDING *
* SECURITY MENU *
```

### Programming and Viewing the Security Codes

1. Press the **S** push button to start programming or changing the Security codes (or to view the codes).

If no code has been programmed, the computer displays NO CODE PROGRAMMED for that particular floor. Press the **S** push button again to start programming the Security code.

```
F1r 1f: NO
CODE PROGRAMMED
```

If a code has already been programmed, the computer displays the security code, with the floor number blinking.

```
F1r 1f: 8r 3f 4f
2r21f31r19f17r
```

2. Press the + and – push buttons to change the **floor number**. The + push button increments the floor number to the next eligible value. The – push button decrements the value.
3. Press the **S** push button to move to the first character of the **security code** (COP button to be pressed). Press the + and – push buttons to change the value of the first character.
4. Repeat these steps (pressing the **S** push button followed by the + and – push buttons) until the desired number of characters are programmed (maximum of 8 characters). The **S** push button moves the blinking cursor. If any character is left blank, or after all eight characters have been programmed, and the **S** push button is pressed, the cursor returns to the floor number.

5. Repeat these steps to program the Security codes for all the floors. You may exit the Building Security Menu at any time during programming by pressing the **N** push button. When the **N** push button is pressed, the LCD will display the following:

```
Exit this menu?
N=No S=Yes
```

6. Press the **S** push button to exit or the **N** push button to return to the previous display. If **S** is pressed, the following will appear (only if changes have been made):

```
Save Changes?
N=No S=Yes
```

7. Press **S** to save the changes or **N** to exit without saving (any original codes will remain in effect if the changes are not saved).

## Passcode Request Menu

The Passcode Request Operation can be used to require a password to be entered in order to run the car on any mode of operation other than **Inspection**.



If the passcode option has not been activated for this controller, the Passcode Request Menu will not appear.

If a passcode has been programmed, the LCD screen will flash the “PASSCODE REQUESTED” message when Passcode Request Operation is activated.

```
PASSCODE REQUEST
PI 8 20:10001000
```

In order to clear or set the Passcode Request Operation, the controller must first be placed into the System Mode (see “F3: System Mode” on page 5-59). By pressing the **N** push button when the display reads “BUILDING SECURITY MENU,” the Passcode Request Menu will appear:

```
*   PASSCODE   *
  REQUEST MENU
Screen 1
```

**Clearing the Passcode** With Screen 1 displayed, press the **S** push button. If Passcode Request Operation is activated, the following screen appears:

```
REQUESTED PASS-
CODE: 00000000
Screen 2
```

The first character of the passcode to be entered will blink. The “+” and “-” push buttons will scroll through the numbers 0-9 and letters A-Z for each character of the passcode. The **N** push button will advance to the next character position of the passcode.

Pressing the **S** push button will cause the program to verify that the passcode entered was correct. If it was not correct, the following screen will appear:

```
* INVALID CODE *
S=CONT.  N=EXIT
Screen 3
```

Pressing the **S** push button will display Screen 2. Pressing the **N** push button from this screen will return the display back to Screen 1.

If the correct passcode was entered, the following screen appears:

```
*  VALID CODE  *
  N=EXIT
Screen 4
```

Pressing the **N** push button will return the display to Screen 1. The car may now be run on Normal operation mode.

**Activating the Passcode** With Screen 1 displayed, press the **S** push button. If Passcode Request Operation is not activated, the following display appears:

```
ACTIVATE
PASSCODE? NO
Screen 5
```

Pressing the **S** push button will toggle the display from “NO” to “YES”. Pressing the **N** push button while “NO” is displayed will return the display back to the Screen 1. Pressing the **N** push button while “YES” is displayed will activate the Passcode Request Operation and return the display back to Screen 1. With Passcode Request Operation *activated*, the passcode must be entered in order to run the car on any mode of operation other than Inspection.

## Load Weigher Thresholds

This menu does not appear if the ANALOG LOAD WEIGHER option in the EXTRA FEATURES MENU is set to NONE. The load weigher (isolated platform, rope tension or crosshead deflection) provides a signal that corresponds to the perceived load in the car. This signal is brought to the control system where it is conditioned, sampled and digitized, and the value is used to calculate the actual load *inside* the elevator. This load value is then used for logical dispatching operations. The load thresholds are user-programmable and determine when each of these logical operations should be performed.

- **LIGHT LOAD WEIGHER (LLW):** This value is used to define the load at which a limited number of car calls is to be registered (anti-nuisance). If the programmed number of car calls is exceeded, all car calls will be canceled.

Example: LLW=20%. If the measured load in the car is less than 20%, the computer will only allow a certain number of car calls to be registered, defined by the parameter LIGHT LOAD WEIGHING? / LIGHT LOAD CAR CALL LIMIT in the EXTRA FEATURES MENU OPTIONS. If the limit is set to a value of three, the computer will only allow three calls to be registered if the load is less than 20%. If a fourth call is registered, all car calls will be canceled.

- **DISPATCH LOAD WEIGHER (DLW):** This value is used to define the load at which the lobby landing door timer is reduced. This threshold should be set to a value (defined in many specifications as 60%) at which it is appropriate to initiate the process of moving the car out of the lobby.
- **HEAVY LOAD WEIGHER (HLW):** This value is used to define the load value at which hall calls should be bypassed.
- **OVERLOAD WEIGHER (OLW):** This value is used to define the load at which it is considered unsafe to move the elevator. When this threshold is exceeded, the car will remain at the floor with doors open. Typically an application that requires OLW will use some type of visual and/or audible indicator to alert elevator passengers that the car is overloaded.

### Adjusting the Load Thresholds

The typical values for the load thresholds are shown below. However, these thresholds are user-adjustable and may be changed at any time.

#### To adjust these thresholds:

1. Enter the SYSTEM mode of operation by placing the *F3* switch in the up position.
2. Press the *N* push button until LOAD WEIGHER THRESHOLDS appears on the LCD display.
3. Press the *S* push button to display the load threshold you wish to set.
4. The value shown is the current threshold value expressed as a percentage of the full load value (see the table above). Press the '+' or '-' push button to adjust the value. If the value is set to 0%, the load weigher function is disabled.
5. Press the *S* push button to select another load threshold to adjust or press the *N* push button to exit this menu.
6. Place the *F3* switch in the down position to exit SYSTEM mode when finished.



## Analog Load Weigher Learn Function

The Analog Load Weigher Learn Function must be performed before the load weigher system will perform properly. With the isolated platform load weigher (MCE), the system simply learns the reference values of the empty and fully loaded car weight. However, with the crosshead deflection load weigher (K-Tech) and the rope tension sensing load weigher (EMCO), the system must learn the reference values at each floor due to the dynamics of the elevator system. This is necessary because the perceived load at the crosshead varies with the position of the car in the hoistway due to the changing proportion of the traveling cable hanging beneath the car and the position of the compensation cables.

The Analog Load Weigher Learn Function is performed as follows:

1. Move the **empty** car to a convenient floor where the test weights are located. It is best to have one person in the machine room and another person at the floor to load the weights.
2. Place the car on Independent Service operation. Place the **F3** switch in the up position and press the **N** push button to select the Analog Load Weigher Learn Function (scrolling message is displayed)
  - ANALOG LOAD WEIGHER LEARN FUNCTION. PRESS S TO START
3. Press the **S** push button to start. The computer responds with one of two scrolling messages:
  - CAR NOT READY TO LEARN, MUST BE ON INDEPENDENT SERVICE
4. Verify that the car has been placed on Independent Service.
  - READY TO LEARN EMPTY CAR VALUES? PRESS S TO START
5. If the empty car values have already been learned and you want to be learn the full car values, press the **N** push button (go to step 9). To begin learning the empty car values, press the **S** push button. The computer displays the message:
  - LEARNING EMPTY CAR VALUES. PRESS N TO ABORT
6. If the Extra Features Menu Option “Analog Load Weigher?” is set to K-TECH, the car will move to the bottom floor, record the empty car value and then move up, stopping at each floor to record the empty car value. When the top floor has been reached, the car will move back to the floor at which the Analog Load Weigher Learn Function was begun and the computer will display the scrolling message:
  - EMPTY CAR LEARN PROCESS COMPLETED. PRESS S TO CONT.
7. If the Extra Features Menu Option “Analog Load Weigher?” is set to MCE, the car will learn the empty car value and then display the message:
  - EMPTY CAR LEARN PROCESS COMPLETED. PRESS S TO CONT.
8. Press the **S** push button. The computer displays the scrolling message:
  - READY TO LEARN FULL CAR VALUES? PRESS S TO START.
9. Place the full load test weights in the car and press the **S** push button to begin learning the full car values. The computer displays the message:
  - LEARNING FULL CAR VALUES. PRESS N TO ABORT.

10. If the Extra Features Menu Option “Analog Load Weigher?” is set to K-TECH, the car will move to the bottom floor, record the full car value and then move up, stopping at each floor to record the full car value. When the top floor has been reached, the car will move back to the floor at which the Analog Load Weigher Learn Function was begun and the computer will display the scrolling message:
  - FULL CAR LEARN PROCESS COMPLETED. PRESS S TO CONT.
11. If the Extra Features Menu Option “Analog Load Weigher?” is set to MCE, the car will learn the full car value and then display the message:
  - FULL CAR LEARN PROCESS COMPLETED. PRESS S TO CONT.
12. Press the **S** push button, place the **F3** switch in the down position and take the car off of Independent service.
13. To verify that the Load Weigher Learn Function has been performed successfully, place the **F8** switch in the up position. With the test weights in the car, the following should be displayed:
  - CURRENT LOAD = 100%
14. If the Load Weigher Learn Function has not been performed successfully, the following will be displayed:
  - CURRENT LOAD = NOT LEARNED
15. The Load Weigher Learn Function (empty or full values) may be aborted at any time by pressing the **N** push button. The computer will display the message:
  - LEARN PROCESS ABORTED... PRESS S TO CONT.
16. When the **S** push button is pressed the computer displays the scrolling message:
  - ANALOG LOAD WEIGHER LEARN FUNCTION. PRESS S TO START
17. At this point you may exit System Mode by placing the **F3** switch in the down position, or you may re-start the learn function by moving the car back to the floor where the test weights are located and press **S** to start (go to step 4).
18. If the empty car values have been learned but the full load learn function was aborted, you need not re-learn the empty car values. When the message READY TO LEARN EMPTY CAR VALUES is displayed, press the **N** push button. The computer will display:
  - READY TO LEARN FULL CAR VALUES? PRESS S TO START.
19. Press the **S** push button to begin learning the full car values (go to step 10).

## Controller System Menu

The following options are set using this menu:

### **AUTOMATIC MODE FAULT BYPASS. JUMPER MUST BE INSTALLED TO ACTIVATE.** (BYPASS ON/BYPASS OFF)

For the purpose of testing and adjustment, this option allows redundancy faults to be bypassed when the controller is on Automatic operation. In order to use this option, a jumper must be placed on JP1 (next to the FAULT RESET button on the HC-CTL board).



Press the **S** push button to toggle the setting to BYPASS ON or BYPASS OFF. A timer will return the controller to BYPASS OFF automatically after two hours. In addition, if the jumper is removed from JP1, the controller is removed from bypass mode.

```
AUTOMATIC MODE F
* BYPASS OFF *
```

### **INSPECTION MODE FAULT BYPASS. JUMPER MUST BE INSTALLED TO ACTIVATE.** (BYPASS ON/BYPASS OFF)

For the purpose of testing and adjustment, this option allows redundancy faults to be bypassed when the controller is on Inspection. In order to use this option, a jumper must be placed on JP1 (next to the FAULT RESET button on the HC-CTL board). Press the S push button to toggle the setting to BYPASS ON or BYPASS OFF. If the jumper is removed from JP1, the controller is removed from bypass mode.

```
INSPECTION MODE
* BYPASS OFF *
```

5

**ANSI 2000 DATA TRAP MEMORY** Not currently used on this product.

### **HIGH SPEED INSPECTION** (ENABLED/DISABLED) -

Determines if the car will run on high or low speed on Inspection. When set to Enabled, the car will run at high speed on Machine Room Inspection, Cartop Inspection or Hoistway Access. The car should not run at high speed on Inspection if contract speed is greater than 150 fpm.

```
HIGH SPEED INSPE
* DISABLED *
```

**ELGO A / ELGO B** Not currently used on this product.

**POSITION / SPEED** Not currently used on this product.

## F4: Messages and Floor Labels

Messages and Floor Labels is used to program the CE fixture displays. To access, move the **F4** switch to the up position. Refer to Figure 5.2 PI Entry Procedure.

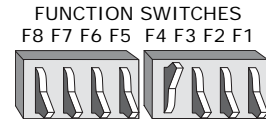

Messages and Floor Labels

```
* MESSAGES AND *
* FLOOR LABELS *
```

```
- MODIFY FLOOR -
- LABELS -
```

```
FLOOR LABEL FOR
LANDING 01: 001
```

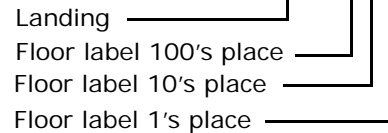

This display changes to:

**Modify Floor Labels** Press the S push button. The display changes to:

Press the S push button again. The display changes to:

- Press + or - push buttons to change landing
- Press S push button to move to first label field
- Press + or - push buttons to change field value
- Press S push button to move to next field
- Repeat until entries completed
- Press N push button to exit.

**Note:** Spaces for three characters (three character display) are provided. If the display has only two characters, use the two right most spaces (ones and tens place) and leave the left most space (hundreds place) blank.

**Modify Message Labels** Per landing/per message, use operating keys as above to set a three-character message to be displayed at each landing for the associated message.

**Initialize all Labels** DEFAULT LABELS [S] - Yes [N] - No. Use this function to initialize all labels to factory defaults. If you do not wish to complete the command, press and hold -, then press N to exit.

Figure 5.2 PI Entry Procedure

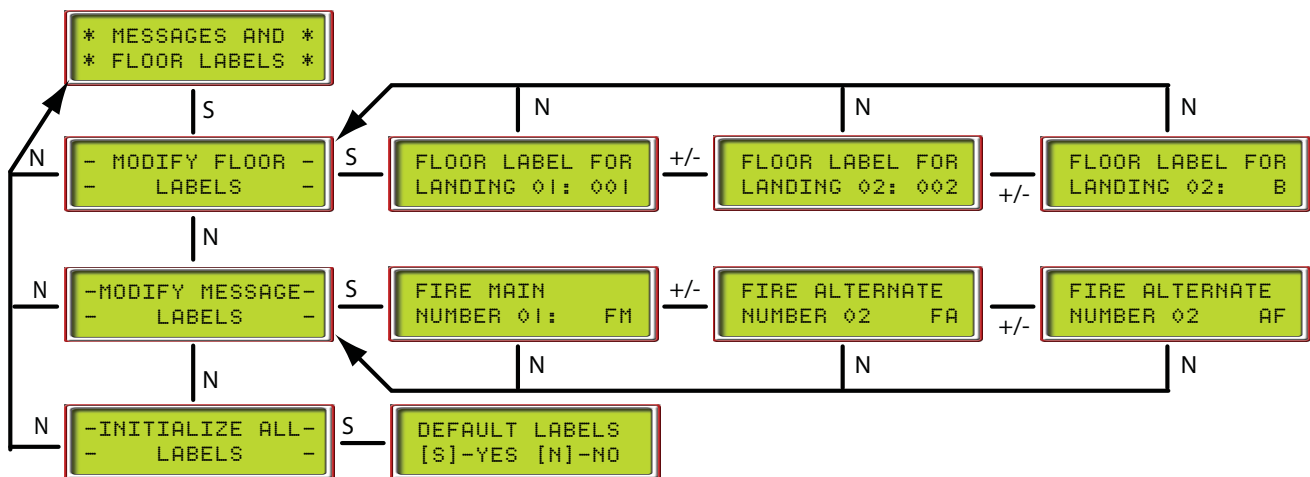

## F5: Controller Utilities/Monitoring and Reporting

Place the F5 switch in the Up position (all others down). This option provides access to the *Controller Utilities Menu* and the *Monitoring and Reporting Menu*.

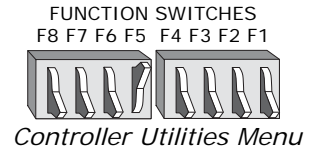

### Controller Utilities Menu

Use this menu to register front and/or rear car calls, set the controller's date and time, view and clear the event log and view the system CAN bus data. If *Controller Utilities Menu* is not displayed, press N push button. Please refer to Figure 5.3.

Figure 5.3 Controller Utilities Menu

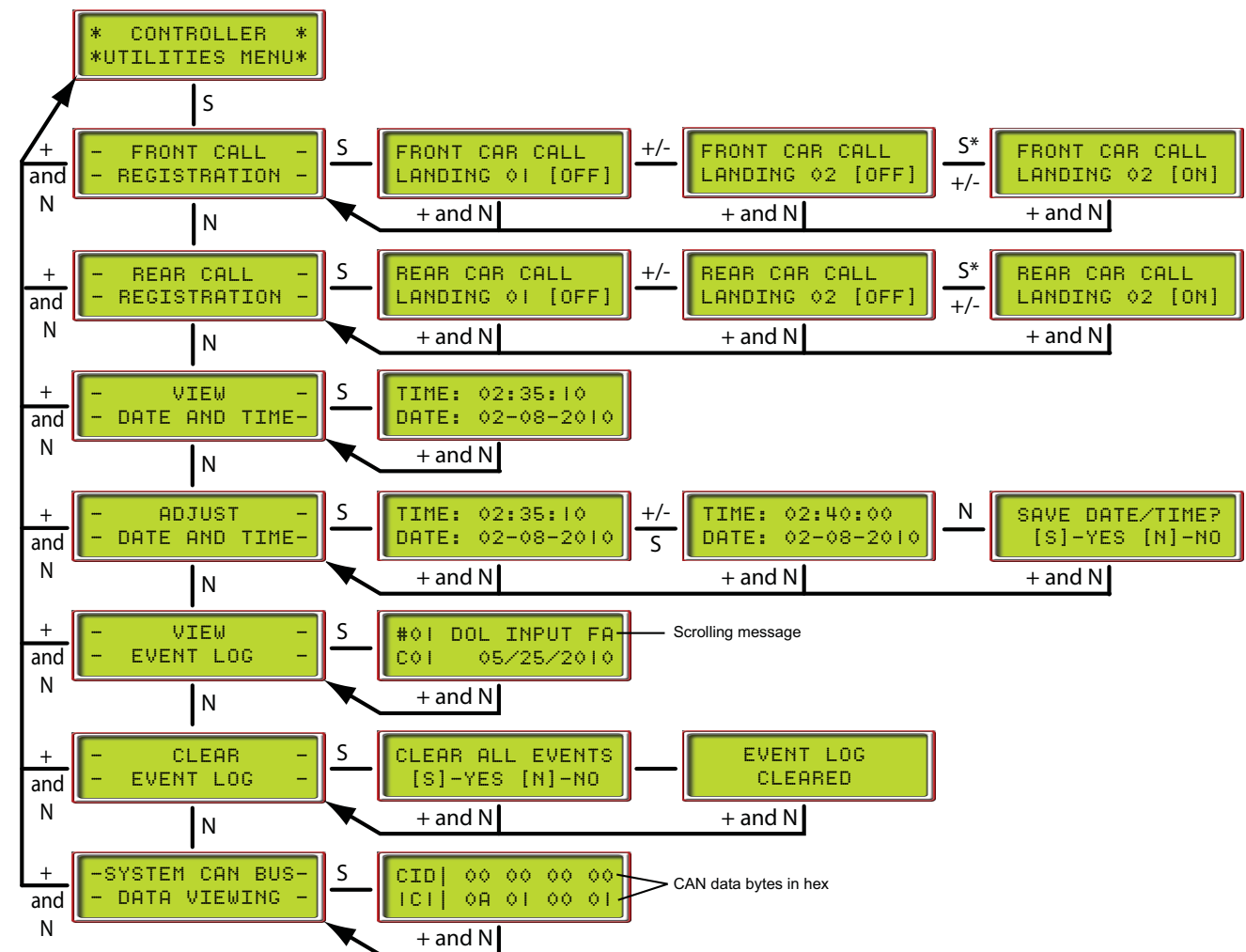

5

### Registering Front or Rear Car Calls

1. Press S push button. Front Call Registration is displayed. Press S to select or press N until Rear Call Registration is displayed and press S to select. Refer to Figure 5.3.
2. Press +/- push buttons to increment or decrement floor numbers.
3. Press and momentarily hold S push button to register calls: displays [ON] while held.
4. Press + and N push buttons together to back out of the current display.

## Date/Time

Use to display and/or set the date and time (see Figure 5.3).

### To view the date and time:

1. Press N until View Date and Time is displayed, then press S. The current date and time is displayed.
2. Press + and N push buttons together to back out of the current display.

```
-      VIEW      -  
- DATE AND TIME -
```

```
TIME: 02:35:10  
DATE: 02-08-2008
```

### To set the date and time:

1. Press N until Adjust Date and Time is displayed, then press S.
2. The current date and time are displayed with the hour blinking. Press + or - to adjust the hour.
3. Continue pressing S to select the minutes, seconds, day, month and year. In each case, press + or - to adjust the setting. When you are finished adjusting the date and time, press N.
4. Press S to save the setting or N to exit without saving.
5. Press + and N push buttons together to back out of the current display.

```
-      ADJUST      -  
- DATE AND TIME -
```

```
TIME: 02:35:10  
DATE: 02-08-2008
```

```
SAVE DATE/TIME?  
[S]-YES [N]-NO
```

## View Event Log

The event log tracks the last 100 events (see Figure 5.3).

- Press S push button to select View Event Log.

The first event is displayed on the top line of the display along with the time and date on the bottom line.

- Press +/- buttons to move to the next or previous event.
- Press + and N push buttons together to back out of the current display.

```
-      VIEW      -  
- EVENT LOG     -
```

```
#01 DOL INPUT F  
C01 05/25/2010
```

## Clear Event Log

This allows you to clear the events from the event log.

1. Press S push button to select Clear Event Log.

A prompt appears:

2. Press S push button to clear the event log.

A message appears notifying you that all events have been cleared.

3. Press + and N push buttons together to back out of the current display.

```
-      CLEAR      -  
- EVENT LOG     -
```

```
CLEAR ALL EVENTS  
[S]-YES [N]-NO
```

### System CAN Bus Data Viewing

The System CAN Bus/Data Viewing display allows you to check the working status of the inputs and outputs of any MC-CPI Car Panel Interface board in the system. (see also Figure 5.3)

```
-SYSTEM CAN BUS-
- DATA VIEWING -
```

- Press S push button to display the data.

```
CID | 00 00 00 00
ICI | 0A 01 00 01
```

CAN Data Bytes in Hex

Three digit MC-CPI address (see table below)

- Use the + or - buttons to increment/decrement address digit value
- Use the S button to move from digit to digit
  - As soon as a valid ID is on the screen, the CAN data from that ID will be visible as the hex data for each CAN byte changes.
  - With the desired ID is selected, you can place a call from the affected control panel, or press a Door Open button, etc. and view the data transfer on the CAN bus.

Table 5.10 MC-CPI Board Addresses

ID	DATA
1C0	Output activity CPI board "0"
1C1	Input activity CPI board "0"
1C2	Output activity CPI board "1"
1C3	Input activity CPI board "1"
1C4	Output activity CPI board "2"
1C5	Input activity CPI board "2"
1C6	Output activity CPI board "3"
1C7	Input activity CPI board "3"
1C8	Output activity CPI board "4"
1C9	Input activity CPI board "4"
1CA	Output activity CPI board "5"
1CB	Input activity CPI board "5"
1CC	Output activity CPI board "6"
1CD	Input activity CPI board "6"
1CE	Output activity CPI board "7"
1CF	Input activity CPI board "7"

## Monitoring and Reporting Menu

If the controller is configured for monitoring or reporting connections through Ethernet, this menu is used to set up the port and to view communication statistics for diagnostic purposes. If *Monitoring and Reporting Menu* is not displayed, press N push button.

- With “Monitoring and Reporting Menu” displayed, press S to enter the menu. The first screen provides a way to exit the menu without making changes. Press N to continue.
- The next screen provides the version number of the monitoring software in the controller. Press N to continue.
- The monitored type screen displays the controller type being monitored. Press N to move on.
- The IP address screen allows the IP address to be set (see note below):
  - Press S to move from digit to digit.
  - Press + or - to change value.
  - Press N to exit.
- The subnet mask screen allows the mask address to be set (see note below):
- The gateway screen allows the gateway address to be set (see note below):

```
*MONITORING AND*
*REPORTING MENU*
```

```
MONITORING MENU
HOLD +&N TO EXIT
```

```
MONITORING VRSN:
001.000.006
```

```
MONITORING TYPE:
M2000 SIMPLEX
```

```
IP Address:
010.010.052.058
```

```
Subnet Mask:
255.255.000.000
```

```
Gateway Address:
010.010.254.254
```



Any time you make a change to an IP Address, Subnet Mask or Gateway Address, you must reset the HC-CHP board (Device) or the XPort. Refer to the information following.

## Diagnostics, Refresh, Reset

The following screens provide diagnostic information, and allow Device and XPort refresh (poll for current data) or reset.

- The connections screen indicates which client connections are active. The XPort has the ability to connect to up to six iMonitors. This screen tells you how many connections are currently active.
- The floors screen provides, left-to-right, the number of cars configured, if the car is a duplex dispatcher (D) or a local (L), and the number of floors configured.

```
CONN 1 2 3 4 5 6
    - - - - -
```

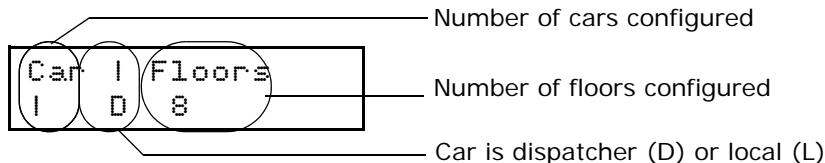



- The XPort Comm Resets screen indicates the number of times the port has been reset since the last HC-CHP reset. If it exceeds three, you may have a network problem.

```
XPort<>PIC COMM:
COMM RESETS: 1
```

- The Receive/Transmit screen monitors the current number of receive and transmit messages in the XPort queue, the peak number of messages in that queue, and the maximum acceptable number of messages in each queue.

```
RQ: 0 Peak 26/60
TQ: 0 Peak 11/35
```

- The error diagnostic displays those data points being checked for change.

```
E: 0 P: 0 M: 29
 /98 / 37 /165
```

E = Events  
P = Parameters  
M = Monitors

- The Device Data screen displays the data byte in a particular register.

```
Device Data:
00000=00000001
```

— Data present

— Register address

- The iReport screen shows the current status of iReport connections (None, Conn, Wait), and the last iReport Port and IP address that was connected.

```
IRprt: 16189 NONE
101.101.011.176
```

— Port

— Status: None, Conn, Wait

— IP address

- The Reset XPort screen allows you to reset the XPort and related counters. Resetting is required after changing IP address, Subnet mask, or Gateway address.

```
Reset XPort?
Press 'S'
```

- Refresh Device allows you to trigger an immediate data gathering cycle to ensure you are seeing the latest processor information.

```
Refresh Device?
Press 'S'
```

- Refresh XPort allows you to trigger an immediate data gathering cycle to ensure you are seeing the latest XPort information (IP address, Gateway address, Subnet Mask, and Type of controller).

```
Refresh XPort?
Press 'S'
```

- The TFTP Status screen allows you to provide permission for an FTP updater to update the monitoring software on this controller.

```
TFTP Status: NO
Press 'S'
```

- The Default XPort screen allows you to default the XPort to original factory programming.

```
Default XPort?
Press 'S'
```

## F8: Status Displays

Displays various system statuses. To view the Status Displays:

1. Place function switch F8 in the up position (all others down).
2. Press N to cycle through available status displays.

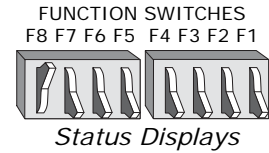

The following status displays are available:

- **Software Version** - Main processor software version number.

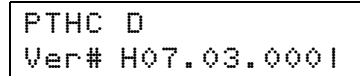

- **Firmware versions for all boards** - To view the listing of firmware versions for all of the boards in the controller, place function switches F8 and F1 in the up position. Then press N to cycle through the complete listing of firmware versions.

- **Eligibility Map** - Door access for each floor (F = front, R = rear, B = both). Read left to right - floors 1 through 16 in the top row, floors 17 through 32 in the bottom row. Please see [“CAR SERVES FRNT/FLR 1? \(simplex\)/THIS CAR SERVES FRNT/FLR 1? \(duplex\)”](#) on page 5-18 and see [“CAR SERVES REAR/FLR 1? \(simplex\) / THIS CAR SERVES REAR/FLR 1? \(duplex\)”](#) on page 5-18 for programming instructions.

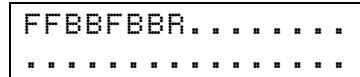

- **Current Load** - The current load in the car as a percentage of full load (analog load weigher required).

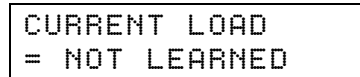

### F1 & F8: Board Software Versions

When both F1 and F8 switches are up, board software version numbers are visible. This can be helpful when troubleshooting with an MCE technician.

- Press N button for versions:
  - MPUA: MPU board software
  - CTLA: Control board A processor software
  - CTLB: Control board B processor software
  - CTLC: Control board C processor software
  - MPJA: Motion Processor board A processor software
  - MPIB: Motion Processor board B processor software
  - MPIC: Motion Processor board C processor software
  - UIO(0 - n): UIO board software
  - CHP: CHP board software

## Duplexing

A great advantage of the Motion 2000 is how easily it can be duplexed. Because the duplexing logic is completely internal to the computers, it requires only a connecting cable and the selection of the Duplex option (see “SIMPLEX / LOCAL OR DUPLEX?” on page 5-17). The duplexing logic provides for proper assignment of hall calls to cars and increases efficiency and decreases waiting time.

### Dispatching Algorithm

The dispatching algorithm for assigning hall calls will be real-time based on estimated time of arrival (ETA). In calculating the estimated time of arrival for each elevator, the dispatcher will consider, but not be limited to, the location of each elevator, the direction of travel, the existing hall call and car call demand, door time, flight time, lobby removal time penalty and coincidence call.

### Hardware Connections

There are two critical items in duplexing hardware: Proper grounding between the two controller subplates and proper installation of the duplexing cable. The hall calls will be connected to both cars simultaneously. Once in a duplex configuration, either of the two controllers can become the dispatcher of hall calls. The controller that assumes the dispatching duty on power up remains the dispatching processor until it is taken out of service. If, for any reason, the communication link between the two controllers does not function, each car will respond to the registered hall calls independently.

### Troubleshooting

In a duplexing configuration, the controller that assumes dispatching duty is identified by the letter *D* in the upper left corner of the LCD display. The other car is identified by the letter *S* (slave), in the upper left corner of the LCD. If the upper left-hand corner of the LCD is blank (neither the *D* nor the *S* is displayed), the cars are not communicating.



## Quick Topics

- [In This Section](#)
- [Troubleshooting Tools](#)
- [Status and Error Messages](#)
- [PC Board Quick References](#)
- [MLT/VLT Data Trap](#)



## Troubleshooting

6

### In This Section

This section contains general troubleshooting related information and tabled information to help you diagnose and correct problems. If you are viewing this on a computer, click the page number to jump to the appropriate section.

- **Troubleshooting Tools:** Lists the troubleshooting tools available (see [page 6-2](#)).
- **Status and Error Messages:** Table includes a description and troubleshooting tips for each message (see [page 6-3](#)).
- **Circuit Board Quick References:** Descriptions of circuit board connections, indicators, jumpers and test points (see [page 6-35](#)).
- **MLT/VLT Data Trap:** Troubleshooting using the Motor Limit Timer / Valve Limit Timer data trap (see [page 6-72](#)).

## Troubleshooting Tools

The following troubleshooting tools are available on the Motion 2000 Hydraulic controller:

- **Status Indicators:** The status indicators on the HC-MPU board provide a quick look at the status of the safety circuit, door locks, and mode of operation, e.g., Independent service, Inspection and Fire service. [Please refer to “Indicators” on page 5-2.](#)
- **Scrolling Messages:** The Status and Error messages are scrolled on the LCD display on the HC-MPU board. This is one of the first places to look for an indication of a problem. A complete list of Status and Error Messages can be found in Section 6. This list includes a description of each message and suggestions for troubleshooting. [Please refer to “Status and Error Messages” on page 6-3.](#)
- **Diagnostic Mode:** A description of how to use the diagnostic mode for troubleshooting is provided in Section 5. [Please refer to “Diagnostic Mode” on page 5-6](#) and see [“Troubleshooting Using the Computer's Internal Memory” on page 5-9.](#)
- **External Memory Mode:** External memory mode can be used to view memory address in external RAM and on the HC-MPU board. Using External Memory Mode for troubleshooting is described in Section 5. [Please refer to “F2: External Memory Mode” on page 5-55.](#)
- **PC Board Quick References:** This section contains information about the circuit boards and assemblies, including photographs with informational call outs, inputs/outputs, indicators, jumpers, test points and other information pertinent to troubleshooting. [Please refer to “PC Board Quick References” on page 6-35.](#)
- **MLT / VLT Data Trap:** The data trap records many of the controller’s operational flags at the moment an MLT or VLT occurs. This allows you to see the status of the flags leading up to the fault. [Please refer to “MC-CPI Car Panel Interface Board” on page 6-62.](#)
- **Motion 2000 Parameter Settings Record:** This table in the Appendix provides a record of the original parameter settings as well as a place to record changes made to the parameters. [Please refer to “Motion 2000 Parameter Settings Record” on page 7-2.](#)
- **Wiring Prints:** MCE job prints are technical drawings and instructions specifically generated for each installation. Use these drawings while tracing problems involving internal and external wiring to the controller. [Please refer to “Wiring Prints” on page 2-5.](#)
- **LS-QUTE Landing System Assembly Drawings:** Use these drawings if it becomes necessary to troubleshoot a problem or replace the HC-IPLS board in the LS-QUTE landing system. [Please refer to “LS-QUTE Landing System Assembly Drawings” on page 7-12.](#)

## Status and Error Messages

While in Diagnostic Mode, the top line of the LCD display shows the prevailing status of the elevator. The message is scrolled.

```
CAR IN TEST MODE
PI 8 20:10110011
```

There is a status message for each special operation (e.g., FIRE SERVICE PHASE 1 - MAIN). There are also messages for most error conditions (e.g., SAFETY CIRCUIT IS OPEN). Table 6.1 provides a complete list of these status and error messages including a description and troubleshooting suggestions.

The following table contains some terms that are unique to MCE or to electronics manufacturing:

- **2 or 2xx Bus:** These are 120VAC buses originating in the controller.
- **IDC:** Insulated Displacement Connectors. These are connectors that allow an insulated wire to be pressed into place where narrow “jaws” cut the insulation to provide positive connection. When an instruction says to “check IDC,” it means to check signal presence at that connector/number, the integrity of the wire, the source connection, and the source signal.
- **NYCHA:** New York City Housing Authority.
- **Data Trap:** An electronic “capture” of the present status, off or on (0 or 1) of eight signals. Used when troubleshooting to see that signals are in the expected state during a particular point of controller operation.
- **Jumper:** A board-mounted connector with exposed, vertical pins that can be shorted together using a small “jumper” designed to slide on to two pins.

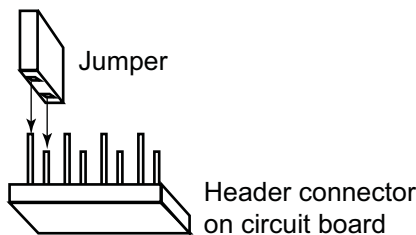

- **PMT:** Panel Mount Terminal. Gray screw-terminals arranged on a length of DIN rail. PMTs provide a convenient point of connection for field wiring.

**Table 6.1 Status and Error Messages**

Scrolling Message - Special Event Message
<b>2 BUS IS LOW (CTLC)</b>
<p><b>Description:</b> The input that monitors the 2 bus is low.</p> <p><b>Troubleshooting:</b></p> <ol style="list-style-type: none"> <li>1. Check the F2 fuse on the HC-CTL board.</li> <li>2. Check IDC X4 on the HC-CTL board.</li> </ol>
<b>2FS BUS IS LOW (CTLC)</b>
<p><b>Description:</b> The input that monitors the 2FS bus is low.</p> <p><b>Troubleshooting:</b></p> <ol style="list-style-type: none"> <li>1. Check the F2FS fuse on the HC-CTL board.</li> <li>2. Check IDC F2FS on the HC-CTL board.</li> </ol>
<b>2HA BUS IS LOW (CTLC)</b>
<p><b>Description:</b> The input that monitors the 2HA bus is low.</p> <p><b>Troubleshooting:</b></p> <ol style="list-style-type: none"> <li>1. Check the F2HA fuse on the HC-CTL board.</li> <li>2. Check IDC X4 on the HC-CTL board.</li> </ol>
<b>2MV BUS IS LOW (CTLC)</b>
<p><b>Description:</b> The input that monitors the 2MV bus is low.</p> <p><b>Troubleshooting:</b></p> <ol style="list-style-type: none"> <li>1. Check the F2MV fuse on the HC-CTL board.</li> <li>2. Check IDC 2MV on the HC-CTL board.</li> </ol>
<b>2S INPUT FAILURE (CTLC)</b>
<p><b>Description:</b> The microcontroller has detected that the 2 bus for safety circuits (2S) input on the HC-CTL board is in an incorrect state. If the SAFC input has 120VAC then 2S must also have 120VAC.</p> <p><b>Troubleshooting:</b></p> <ol style="list-style-type: none"> <li>1. Check the wiring or devices connected to the SAFC input.</li> <li>2. Check the ICS relay.</li> </ol>
<b>ABD INPUT FAILURE (CTLB)</b>
<p><b>Description:</b> The Bottom Down Access (ABD) switch is high when 2HA bus is low.</p> <p><b>Troubleshooting:</b></p> <ol style="list-style-type: none"> <li>1. Check for incorrect wiring or short on the HC-CTL board ABD input and 2HA or 2 bus</li> <li>2. Check the bottom access switch and associated wiring per the job prints.</li> </ol>
<b>ABU INPUT FAILURE (CTLB)</b>
<p><b>Description:</b> The Hoistway Access Bottom Up (ABU) switch is high when 2HA bus is low.</p> <p><b>Troubleshooting:</b></p> <ol style="list-style-type: none"> <li>1. Check for incorrect wiring or short on the HC-CTL board ABU input and 2HA or 2 bus.</li> <li>2. Check the bottom access switch and associated wiring per the job prints.</li> </ol>
<b>ACCESS ENABLED (CTLA)</b>
<p><b>Description:</b> The controller is in Inspection Access mode, activated by either 120VAC at the Access Enable Switch input (screw terminal INA) on the HC-CTL board or by placing the front or rear hoistway or car door bypass switches in the bypass position.</p>
<b>ATD INPUT FAILURE (CTLB)</b>
<p><b>Description:</b> The Top Down Access (ATD) switch is high when 2HA bus is low.</p> <p><b>Troubleshooting:</b></p> <ol style="list-style-type: none"> <li>1. Check for incorrect wiring or short on the HC-CTL board ATD input and 2HA or 2 bus.</li> <li>2. Check the top access switch and associated wiring per the job prints.</li> </ol>



**Table 6.1 Status and Error Messages**

Scrolling Message - Special Event Message
<b>ATTENDANT SERVICE OPERATION</b>
<p><b>Description:</b> The car is on attendant operation. The attendant service input (ATS) is activated.  <b>Troubleshooting:</b> Go into Program Mode and check to see if any spare inputs are programmed as ATS. Then check to see if that particular input is activated.</p>
<b>ATU INPUT FAILURE (CTLB)</b>
<p><b>Description:</b> The Top Up Access (ATU) switch is high when 2HA bus is low.  <b>Troubleshooting:</b></p> <ol style="list-style-type: none"> <li>1. Check for incorrect wiring or short on the HC-CTL board ATU input and 2HA or 2 bus.</li> <li>2. Check the top access switch and associated wiring per the job prints.</li> </ol>
<b>AUXILIARY STARTER TIMEOUT</b>
<p><b>Description:</b> One of the auxiliary starters did not start properly.  <b>Troubleshooting:</b> On a solid state starter, the DR1 input did not go high within the time programmed in the UP TO SPEED TIMER parameter (1.0 - 8.0 sec).</p>
<b>BOTTOM ACCESS SW. FAILURE (CTLB)</b>
<p><b>Description:</b> The Up and Down Bottom Access inputs are active at the same time.  <b>Troubleshooting:</b> Check the wiring and switches associated with the ABU and ABD inputs.</p>
<b>BOTTOM FLOOR OR TOP FLOOR DEMAND</b>
<p><b>Description:</b> The controller is trying to establish the position of the car by sending it to either the top or the bottom. Usually associated with bottom floor demand. Bottom Floor Demand has four possible causes:</p> <ol style="list-style-type: none"> <li>1. A change from Inspection to Automatic operation.</li> <li>2. Pressing the COMPUTER RESET button.</li> <li>3. Initial Power-up.</li> <li>4. If the car is at the top floor, and the controller gets an up slow down signal (USD), the controller will create a Bottom Floor Demand.</li> </ol> <p><b>Troubleshooting:</b> Bottom Floor Demand should be cleared when all of the following conditions are met:</p> <ol style="list-style-type: none"> <li>1. The car is at the bottom and the down slow down (DSD) input to the controller is <i>OFF</i> (because the switch should be open).</li> <li>2. The Door Zone (DZ) input to the controller is <i>ON</i>.</li> <li>3. The Door Lock (DLK) input to the controller is <i>ON</i>.</li> </ol> <p>If the car is at the bottom, and the message still flashes, check the Down Slow Down switch &amp; associated wiring. Also, inspect the door zone landing system vane or magnet at the bottom floor and the door lock circuit.</p> <p>Top Floor Demand should be cleared when all of the following conditions are met:</p> <ol style="list-style-type: none"> <li>1. The car is at the top and the up slow down (USD) input to the controller is <i>OFF</i> (because the switch should be open).</li> <li>2. The Door Zone (DZ) input to the controller is <i>ON</i>.</li> <li>3. The Door Lock (DLK) input to the controller is <i>ON</i>.</li> </ol> <p>If the car is at the top, and the message still flashes, inspect the Up Slow Down Switch &amp; associated wiring. Also, inspect the door zone landing system vane or magnet at the top floor and the door lock circuit.</p> <p>NOTE: If the controller has the absolute floor encoding feature, then the Bottom and Top Floor Demands should be cleared when the car stops in any door zone. The car does not have to travel to the top or bottom.</p>
<b>CAPTURE FOR TEST</b>
<p><b>Description:</b> CTST input has been activated.  <b>Troubleshooting:</b> Go into Program Mode. Check the spare inputs to see if any are programmed as CTST. Ensure that this input is NOT activated.</p>

**Table 6.1 Status and Error Messages**

Scrolling Message - Special Event Message
<b>CAR CALL BUS IS DISCONNECTED</b>
<p><b>Description:</b> Usually indicates a problem in the wiring or fuses. There is no power to the Car Call circuits.</p> <p><b>Troubleshooting:</b> Check the Car Call Bus fuse. Check the wires that go to the Car Call Power inputs in the controller.</p>
<b>CAR DOOR BYPASS SW. FAILURE (CTLA)</b>
<p><b>Description:</b> Indicates that the CAR DOOR BYPASS switch has failed.</p> <p><b>Troubleshooting:</b></p> <ol style="list-style-type: none"> <li>1. Cycle the HC-CTL board car door bypass switch a few times to exercise it. Verify that it is fully in the ON or OFF position.</li> <li>2. Verify 2S and GS connections and wiring.</li> </ol>
<b>CAR IN TEST MODE</b>
<p><b>Description:</b> The spare input TEST has been activated.</p> <p><b>Troubleshooting:</b> Check the TEST/NORM switch on the HC-CTL Board.</p>
<b>CAR SAFETY DEVICE OPEN</b>
<p><b>Description:</b> One of the car safety devices has activated, opening the safety circuit (e.g., emergency exit contact, safety clamp switch, car-top emergency stop switch).</p> <p><b>Troubleshooting:</b> Check all car safety devices. Refer to controller wiring prints for applicable devices. Verify that the SAFC terminal on the HC-CTL board is powered.</p>
<b>CAR TO FLOOR FUNCTION</b>
<p><b>Description:</b> The CTF input has been activated.</p> <p><b>Troubleshooting:</b> Go into Program Mode and see if any spare inputs are programmed as CTF. Then, check to see if that particular input is activated.</p>
<b>CAR TO LOBBY OPERATION</b>
<p><b>Description:</b> The CTL input has been activated.</p> <p><b>Troubleshooting:</b> Go into Program Mode and see if any spare inputs are programmed as CTL. Then, check to see if that particular input is activated.</p>
<b>CAR TOP INSPECTION (CTLA)</b>
<p><b>Description:</b> The controller is currently in CAR TOP inspection. This indicates 120VAC at screw terminal INCT on the HC-CTL board.</p>
<b>CONFIGURATION ERROR-CHANGE SETTINGS BEFORE INSTALLATION</b>
<p><b>Description:</b> Incorrect Programmed value(s), e.g., a floor selected for the fire floor is not one at which the elevator stops.</p> <p><b>Troubleshooting:</b> Go into Program Mode. Check all of the values associated with stops &amp; special floors. Save the values.</p> <p>If this message reoccurs after cycling power to the controller, the memory backup battery on the HC-MPU board may have a low voltage. The voltage of the coin shaped CR2032 battery should about 3Vdc. If the battery was low, be sure to default the parameters before reprogramming the controller parameters (see <a href="#">"Setting Parameters (Options) to Default Values "</a> on page 5-13).</p>
<b>CONTACTOR PROOFING REDUNDANCY FAILURE</b>
<p><b>Description:</b> The main power contactors that provide power to the motor have not dropped out in their intended manner.</p> <p><b>Troubleshooting:</b> Inspect the main power contactors to ensure that they are working as intended. Ensure that there is power on the CNP input when the car is not in motion.</p>

Table 6.1 Status and Error Messages

Scrolling Message - Special Event Message
<p><b>DCAB INPUT FAILURE (CTLA)</b></p> <p><b>Description:</b> The Bottom Access Door Contact (DCAB) input monitors the bottom door closed contacts. DCAB should be 120VAC during bottom access operation and Bottom Access switch is toggled in the up or down position.</p> <p><b>Troubleshooting:</b></p> <ol style="list-style-type: none"> <li>1. Verify 120VAC on the 2S bus.</li> <li>2. Check that all hoistway doors are closed except for the bottom access hoistway door.</li> <li>3. Check for 120VAC on the DCMS terminal.</li> </ol>
<p><b>DCLCR INPUT FAILURE (RDRA)</b></p> <p><b>Description:</b> The Rear Door Close Limit Contact (DCLCR) input monitors the rear door closed contacts. DCLCR should be 120VAC during bottom rear access operation and Bottom Access switch is toggled in the up or down position.</p> <p><b>Troubleshooting:</b></p> <ol style="list-style-type: none"> <li>1. Verify 120VAC on the 2S bus.</li> <li>2. Check that all hoistway doors are closed except for the bottom rear access hoistway door.</li> <li>3. Check for 120VAC on the DCLCR terminal.</li> </ol>
<p><b>DL INPUT FAILURE (CTLB)</b></p> <p><b>Description:</b> The Door Lock (DL) input has detected a failure of the Hoistway Door Bypass (HDBA) or Bottom Access Bypass (BABA) outputs or the Gate Switch (GS), Door Position Monitor (DPM) or Door Lock Access.</p> <p><b>Troubleshooting:</b></p> <ol style="list-style-type: none"> <li>1. Check voltage on HC-CTL board terminal DLAB. DPM should activate two inches before DLAB.</li> <li>2. If DL is active, GS must also be active.</li> </ol>
<p><b>DLR INPUT FAILURE (RDRB)</b></p> <p><b>Description:</b> The Rear Door Lock (DLR) input has detected a failure of the Rear Hoistway Door Bypass (HDBBR) or Rear Bottom Access Bypass (BABBR) outputs or the Rear Gate Switch (GSR), Rear Door Position Monitor (DPMR) or Rear Door Lock Access Bypass (DLABR) inputs.</p> <p><b>Troubleshooting:</b></p> <ol style="list-style-type: none"> <li>1. Check voltage on HC-RDR board terminal DLABR. DPMR should activate two inches before DLABR.</li> <li>2. If DLR is active, GSR must also be active.</li> </ol>
<p><b>DOL INPUT FAILURE (CTLB)</b></p> <p><b>Description:</b> The Door Open Limit (DOL) input is not in the correct state for the position of the door as determined by the Door Position Monitor (DPM) input and the Gate Switch (GS) input.</p> <p><b>Troubleshooting:</b></p> <ol style="list-style-type: none"> <li>1. If DPM is high, DOL must also be high. Check the wiring to terminal DOL on HC-CTL or HC-UIO-board.</li> <li>2. If the GS input is high, DOL must also be high. Check the wiring to terminal GS.</li> </ol>
<p><b>DOLR INPUT FAILURE (RDRB)</b></p> <p><b>Description:</b> The Rear Door Open Limit (DOLR) input is not in the correct state for the position of the door as determined by the Rear Door Position Monitor (DPMR) input and the Rear Gate Switch (GSR) input.</p> <p><b>Troubleshooting:</b></p> <ol style="list-style-type: none"> <li>1. If DPMR is high, DOLR must also be high. Check the wiring to terminal DOLR on HC-RDR or HC-UIO board.</li> <li>2. If the GSR input is high, DOLR must also be high. Check the wiring to terminal GSR.</li> </ol>

**Table 6.1 Status and Error Messages**

Scrolling Message - Special Event Message
<b>DOOR CLOSE PROTECTION TIMER ELAPSED</b>
<p><b>Description:</b> A failure to lock the doors is detected. This failure condition exists when the doors have closed (DCLC = 1 or DCL = 0/DPM=1) a demand exists for the car to move (DCP=1),but the doors are not locked (DLK = 0) within 60 seconds.</p> <p><b>Troubleshooting:</b> If the Retiring Cam option is set, verify the Retiring Cam relay is activated (DCP=1, DCL=0/DPM=1 or DCLC=1) and the doors lock (DLK=1). If no Retiring Cam is used, verify the door lock circuitry contacts are closed to provide power to the door lock input (DLK=1). When a predetermined number of sequential failures is detected, default set to four, the car will shutdown. The failure will be reset once the doors are locked (DLK=1), if the car is placed on Inspection, or the Computer Reset Button is pressed.</p>
<b>DOOR ZONE SENSOR FAILURE - OFF POSITION</b>
<p><b>Description:</b> Indicates that the car completed a run, but did not see door zone.</p> <p><b>Troubleshooting:</b> Reset this fault by pressing the Fault Reset button or by toggling MACHINE ROOM INSPECTION INSP/NORM switch. Run the car to the same floor and verify that DZ=1 or DZR=1. Check placement of DZ magnets.</p>
<b>DOOR ZONE SENSOR FAILURE - ON POSITION</b>
<p><b>Description:</b> The controller computer detected that one of the DZ inputs (front or rear) did not transition to the low state during the last elevator run. Probable cause may be:</p> <ol style="list-style-type: none"> <li>1. A faulty door zone sensor or associated circuitry (within the landing system assembly);</li> <li>2. Faulty wiring from the landing system to the controller;</li> <li>3. Faulty computer input circuit (HC-CTL Control board).</li> </ol> <p><b>Troubleshooting:</b> Check operation of the door zone sensors and associated wiring (place car on inspection, move car away from the floor, noting the transitions in the door zone signal(s) coming from the landing system). Verify that the computer diagnostic display of DZ (or DZ rear) matches the state of the sensor signals at the HC-CTL Control board (or HC-RDR Rear Door board).</p>
<b>DOWN NORMAL LIMIT OPEN (Hydro only)</b>
<p><b>Description:</b> This message indicates that the car has traveled beyond the bottom terminal landing and has opened the down normal (directional) terminal switch.</p> <p><b>Troubleshooting:</b></p> <ol style="list-style-type: none"> <li>1. Check the location of the car.</li> <li>2. Check the voltage at terminal DNTD.</li> <li>3. Check the limit switch connections.</li> </ol>
<b>DOWN TERMINAL LIMIT FAILURE (Hydro only)</b>
<p><b>Description:</b> Both the Down Slow Limit and Down Emergency Limit switches have been detected to be in opposite states. These switches should open/close simultaneously, meaning that the voltage at these terminals should always be identical.</p> <p><b>Troubleshooting:</b></p> <ol style="list-style-type: none"> <li>1. Check the connections to terminals DSL1 and DSL2.</li> <li>2. Check the limit switches for proper operation.</li> </ol>
<b>DPM REDUNDANCY FAULT</b>
<p><b>Description:</b> A failure of a front door input, relay or associated circuitry has been detected. This logic detects failure of the input structure and hardware associated with the DPM (Door Position Monitor) input.</p> <p><b>Troubleshooting:</b> Valid when SAF=1.</p> <ol style="list-style-type: none"> <li>1. Verify that when DLK is ON (1) DPM is also ON (1). When DOL = 0, DPM = 0.</li> <li>2. Verify that DPM makes (120Vac) 1" to 2" prior to door lock.</li> <li>3. Check the associated input circuitry.</li> </ol>

**Table 6.1 Status and Error Messages**

Scrolling Message - Special Event Message
<b>DPMR REDUNDANCY FAULT</b>
<p><b>Description:</b> A failure of a rear door input, relay or associated circuitry has been detected. This logic detects failure of the input structure and hardware associated with the DPMR (Door Position Monitor Rear) input.</p> <p><b>Troubleshooting:</b></p> <ol style="list-style-type: none"> <li>1. Verify that when DLK is ON (1) DPMR is also ON (1). When DOLR = 0, DPMR = 0.</li> <li>2. Verify that DPMR makes (120Vac) 1" to 2" prior to door lock.</li> <li>1. Check the associated input circuitry.</li> </ol>
<b>DRD (UP TO SPEED) FAILED TO ACTIVATE</b>
<p><b>Description:</b> The DRD input that monitors the UP TO SPEED output from the solid state starter did not go high when expected.</p> <p><b>Troubleshooting:</b></p> <ol style="list-style-type: none"> <li>1. Check the wiring associated with the solid state starter, especially terminal SSD.</li> <li>2. This message may also be displayed if the UP TO SPEED timer duration is shorter than the amount of time it takes to ramp the motor up to operating speed.</li> <li>3. If any faults are displayed on the solid state starter refer to the starter manual.</li> </ol>
<b>DRD INPUT FAILURE</b>
<p><b>Description:</b> The Delta Redundancy (DRD) input monitors the normally closed auxiliary contact of the Delta contactor.</p> <p><b>Troubleshooting:</b></p> <ol style="list-style-type: none"> <li>1. Verify that the STARTER #1 (2, 3) TYPE parameter setting is correct (see page 5-53). This fault is generated if the starter is solid-state but the starter type parameter is set to WYE-DELTA.</li> <li>2. Verify that voltage of the coin shaped battery (CR2032) on the HC-MPU board is about 3Vdc.</li> <li>3. The wiring or devices connected to DR1 input may not be terminated.</li> <li>4. Check the Delta auxiliary contact wired to terminal DR1 and replace if necessary.</li> </ol>
<b>DVR 1 IS OFFLINE (CTLA) (Hydro only)</b>
<p><b>Description:</b> Driver board HC-DVR #1 is offline.</p> <p><b>Troubleshooting:</b></p> <ol style="list-style-type: none"> <li>1. Power to the HC-DVR board may not be connected. Check the CAN bus connection between the HC-DVR board and the HC-CHP CAN hub and power distribution board.</li> <li>2. Make sure that the shunt has been removed from JP1 on the HC-DVR board.</li> <li>3. Verify the SW1 settings on HC-DVR board #1: 1 = Off, 2 = Off.</li> <li>4. If the DVR 1 indicator is not lit, reboot the processor by cycling the power to the controller or by removing the CAN bus connection to the HC-DVR board for a few seconds.</li> <li>5. Place Function Switches F1 and F8 in the ON (up) position and press N. Inability to locate the version info for the HC-DVR board indicates that it is not communicating with the HC-MPU board. The HC-DVR board may need to be replaced.</li> </ol>
<b>DVR 2 IS OFFLINE (CTLB) (Hydro only)</b>
<p><b>Description:</b> Driver board HC-DVR #2 is offline. See also, DVR 1 IS OFFLINE -car has two starters.</p> <p><b>Troubleshooting:</b></p> <ol style="list-style-type: none"> <li>1. Power to the HC-DVR board may not be connected. Check the CAN bus connection between the HC-DVR board and the HC-CHP CAN hub and power distribution board.</li> <li>2. Make sure that the shunt has been removed from JP1 on the HC-DVR board.</li> <li>3. Verify the SW1 settings on HC-DVR board #1: 1 = Off, 2 = Off.</li> <li>4. Verify the SW1 settings on HC-DVR board #2: 1 = On, 2 = Off.</li> <li>5. Verify that the setting for NUMBER OF MOTOR STARTERS = 2.</li> <li>6. Verify that the setting for STARTER #2 TYPE is correct.</li> <li>7. If the DVR 2 indicator is not lit, reboot the processor by cycling the power to the controller or by removing the CAN bus connection to the HC-DVR board for a few seconds.</li> <li>8. Place Function Switches F1 and F8 in the ON (up) position and press N. Inability to locate the version info for the HC-DVR board indicates that it is not communicating with the HC-MPU board. The HC-DVR board may need to be replaced.</li> </ol>

**Table 6.1 Status and Error Messages**

Scrolling Message - Special Event Message
<b>DVR 2 MSSD FAILED ACTIVE (CTLA) (Hydro only)</b>
<p><b>Description:</b> When the controller is configured for a solid state starter, output terminal SSD on HC-DVR board #2 has 120 VAC while solid state device U1 is not in the On state.</p> <p><b>Troubleshooting:</b></p> <ol style="list-style-type: none"> <li>1. Verify the SW1 settings on HC-DVR board #1: 1 = Off, 2 = Off.</li> <li>2. Verify the SW1 settings on HC-DVR board #2: 1 = On, 2 = Off.</li> <li>3. Verify that the setting for NUMBER OF MOTOR STARTERS = 2.</li> <li>4. Verify that the setting for STARTER #2 TYPE is correct.</li> <li>5. Verify that voltage is not being fed to terminal SSD on HC-DVR board #2 from another source.</li> <li>6. Verify that solid-state device U1 has not been damaged by shorted wiring connected to terminal SSD (Call MCE Tech Support for details).</li> </ol>
<b>DVR 3 IS OFFLINE (CTLB) (Hydro only)</b>
<p><b>Description:</b> Driver board HC-DVR #3 is offline. See also, DVR 1 IS OFFLINE and DVR 2 IS OFFLINE - car has three starters.</p> <p><b>Troubleshooting:</b></p> <ol style="list-style-type: none"> <li>1. Power to the HC-DVR board may not be connected. Check the CAN bus connection between the HC-DVR board and the HC-CHP CAN hub and power distribution board.</li> <li>2. Make sure that the shunt has been removed from JP1 on the HC-DVR board.</li> <li>3. Verify the SW1 settings on HC-DVR board #1: 1 = Off, 2 = Off.</li> <li>4. Verify the SW1 settings on HC-DVR board #2: 1 = On, 2 = Off.</li> <li>5. Verify the SW1 settings on HC-DVR board #3: 1 = Off, 2 = On.</li> <li>6. Verify that the setting for NUMBER OF MOTOR STARTERS = 3.</li> <li>7. Verify that the setting for STARTER #3 TYPE is correct.</li> <li>8. If the DVR 2 indicator is not lit, reboot the processor by cycling the power to the controller or by removing the CAN bus connection to the HC-DVR board for a few seconds.</li> </ol>
<b>DVR-'n' AUXILIARY STARTER TIMEOUT (n = 2 or 3) (Hydro only)</b>
<p><b>Description:</b> One of the auxiliary starters did not start properly.</p> <p><b>Troubleshooting:</b> On a solid state starter, the DR1 input did not go high within the time programmed in the UP TO SPEED TIMER parameter (1.0 - 8.0 sec).</p>
<b>DVR-'n' DOWN NORMAL LIMIT OPEN (n = 2 or 3) (Hydro only)</b>
<p><b>Description:</b> This message indicates that the car has traveled beyond the bottom terminal landing and has opened the down normal (directional) terminal switch.</p> <p><b>Troubleshooting:</b></p> <ol style="list-style-type: none"> <li>1. Check the location of the car.</li> <li>2. Check the voltage at terminal DNTD.</li> <li>3. Check the limit switch connections.</li> </ol>
<b>DVR-'n' DOWN TERMINAL LIMIT FAILURE (n = 2 or 3) (Hydro only)</b>
<p><b>Description:</b> Both the Down Slow Limit and Down Emergency Limit switches have been detected to be in opposite states. These switches should open/close simultaneously, meaning that the voltage at these terminals should always be identical.</p> <p><b>Troubleshooting:</b></p> <ol style="list-style-type: none"> <li>1. Check the connections to terminals DSL1 and DSL2.</li> <li>2. Check the limit switches for proper operation.</li> </ol>
<b>DVR-'n' DRD (UP TO SPEED) FAILED TO ACTIVATE (n = 2 or 3) (Hydro only)</b>
<p><b>Description:</b> The DRD input that monitors the UP TO SPEED output from the solid state starter did not go high when expected.</p> <p><b>Troubleshooting:</b></p> <ol style="list-style-type: none"> <li>1. Check the wiring associated with the solid state starter, especially terminal SSD.</li> <li>2. This message may also be displayed if the UP TO SPEED timer duration is shorter than the amount of time it takes to ramp the motor up to operating speed.</li> <li>3. If any faults are displayed on the solid state starter refer to the starter manual.</li> </ol>

**Table 6.1 Status and Error Messages**

Scrolling Message - Special Event Message
<b>DVR-'n' DRD INPUT FAILURE</b> (n = 2 or 3) <i>(Hydro only)</i>
<p><b>Description:</b> The Delta Redundancy (DRD) input monitors the normally closed auxiliary contact of the Delta contactor.</p> <p><b>Troubleshooting:</b></p> <ol style="list-style-type: none"> <li>1. Verify that the STARTER #1 (2, 3) TYPE parameter setting is correct (see page 5-53). This fault is generated if the starter is solid-state but the starter type parameter is set to WYE-DELTA.</li> <li>2. Verify that voltage of the coin shaped battery (CR2032) on the HC-MPU board is about 3Vdc.</li> <li>3. The wiring or devices connected to DR1 input may not be terminated.</li> <li>4. Check the Delta auxiliary contact wired to terminal DR1 and replace if necessary.</li> </ol>
<b>DVR-'n' EXCESSIVE NUMBER OF FAILED START ATTEMPTS</b> (n = 2 or 3) <i>(Hydro only)</i>
<p><b>Description:</b> The starter failed to start after three consecutive attempts.</p> <p><b>Troubleshooting:</b> Check the fault log to see what faults were generated when attempting to run the starter.</p>
<b>DVR-'n' M2L INPUT FAILURE</b> (n = 2 or 3) <i>(Hydro only)</i>
<p><b>Description:</b> The M2L input monitors the status of the relay contacts of SAFL and SAFS against the circuits that drive these relay coils. Bus 2L should be 120VAC and relay SAFL should be picked only if the doors are locked. 2MV bus must also be active.</p> <p><b>Troubleshooting:</b></p> <ol style="list-style-type: none"> <li>1. Check or replace relays SAFL and/or SAFS on the HC-CTL board.</li> <li>2. Verify that IDC terminal 2L on the HC-CTL board connects to IDC terminal 2L on the HC-DVR board.</li> <li>3. Check the thermal overload wiring between terminals TO1 and TO2 on the HC-DVR board.</li> <li>4. Check the wiring of the starter overload between terminal OL1 and OL2 (if present).</li> </ol>
<b>DVR-'n' MDFE FAILED TO ACTIVATE</b> (n = 2 or 3) <i>(Hydro only)</i>
<p><b>Description:</b> The MDFE input monitors the status of the DFE triac and the DFE triac driver. When either fails to activate when expected this fault is generated. When the doors are locked, the 2L bus is high, DSL1 and DSL2 limits are closed, the down normal limit (DNTD) is closed and the car is idle, terminals DF and DFE should 120VAC.</p> <p><b>Troubleshooting:</b></p> <ol style="list-style-type: none"> <li>1. Check the associated wiring.</li> <li>2. Check the down fast valve coil.</li> <li>3. Run the car down on inspection and verify that terminal DFE goes low.</li> <li>4. The DFE triac may have failed open. Replace the HC-DVR board.</li> </ol>
<b>DVR-'n' MDFE FAILED TO DEACTIVATE</b> (n = 2 or 3) <i>(Hydro only)</i>
<p><b>Description:</b> The MDFE input monitors the status of the DFE triac and the DFE triac driver. When either fails to deactivate when expected this fault is generated. When the doors are locked, the 2L bus is high, DSL1 and DSL2 limits are closed, the down normal limit (DNTD) is closed and the car is idle, terminals DF and DFE should 120VAC.</p> <p><b>Troubleshooting:</b></p> <ol style="list-style-type: none"> <li>1. Check the associated wiring.</li> <li>2. Check the down fast valve coil.</li> <li>3. The DFE triac may have shorted. Replace the HC-DVR board.</li> </ol>

**Table 6.1 Status and Error Messages**

Scrolling Message - Special Event Message
<b>DVR-'n' MDSE FAILED TO ACTIVATE</b> (n = 2 or 3) <i>(Hydro only)</i>
<p><b>Description:</b> The MDSE input monitors the status of the DSE triac and the DSE triac driver. When either fails to activate when expected this fault is generated. When the doors are locked, the 2L bus is high, the down normal limit (DNTD) is closed and the car is idle, terminals DS and DSE should 120VAC.</p> <p><b>Troubleshooting:</b></p> <ol style="list-style-type: none"> <li>1. Check the associated wiring.</li> <li>2. Check the down slow valve coil.</li> <li>3. Run the car down on inspection and verify that terminal DSE goes low.</li> <li>4. The DSE triac may have failed open. Replace the HC-DVR board.</li> </ol>
<b>DVR-'n' MDSE FAILED TO DEACTIVATE</b> (n = 2 or 3) <i>(Hydro only)</i>
<p><b>Description:</b> The MDSE input monitors the status of the DSE triac and the DSE triac driver. When either fails to deactivate when expected this fault is generated. When the doors are locked, the 2L bus is high, the down normal limit (DNTD) is closed and the car is idle, terminals DS and DSE should 120VAC.</p> <p><b>Troubleshooting:</b></p> <ol style="list-style-type: none"> <li>1. Check the associated wiring.</li> <li>2. Check the down slow valve coil.</li> <li>3. The DSE triac may have shorted. Replace the HC-DVR board.</li> </ol>
<b>DVR-'n' MRD INPUT FAILURE</b> (n = 2 or 3) <i>(Hydro only)</i>
<p><b>Description:</b> The M Contactor Redundancy (MRD) input monitors the normally closed auxiliary contact of the M contactor.</p> <p><b>Troubleshooting:</b></p> <ol style="list-style-type: none"> <li>1. The wiring or devices connected to MR1 input may not be terminated.</li> <li>2. Check the M auxiliary contact wired to terminal MR1 and replace if necessary.</li> <li>3. Check the operation of the M contactor.</li> </ol>
<b>DVR-'n' MSSD FAILED TO ACTIVATE</b> (n = 2 or 3) <i>(Hydro only)</i>
<p><b>Description:</b> MSSD monitors the solid state output of U1 and driver TY for proper operation. If either fail in the off position this fault is generated. When terminal OL2 is 120VAC and the car is commanded to run up, terminal SSD should be 120VAC.</p> <p><b>Troubleshooting:</b></p> <ol style="list-style-type: none"> <li>1. Check the wiring at terminal SSD and OL2.</li> </ol>
<b>DVR-'n' MSSD FAILED TO DEACTIVATE</b> (n = 2 or 3) <i>(Hydro only)</i>
<p><b>Description:</b> MSSD monitors the solid state output of U1 and driver TY for proper operation. If either fail in the on position this fault is generated. When either fails to deactivate when expected this fault is generated. When the OL2 is 120VAC and the car is idle, terminal SSD should be low.</p> <p><b>Troubleshooting:</b></p> <ol style="list-style-type: none"> <li>1. Check terminal SSD wiring.</li> <li>2. Replace the HC-DVR board.</li> </ol>
<b>DVR-'n' MTD FAILED TO ACTIVATE</b> (n = 2 or 3) <i>(Hydro only)</i>
<p><b>Description:</b> The MTD input monitors the status of the TD triac and the TD triac driver. When either fails to activate when expected this fault is generated.</p> <p><b>Troubleshooting:</b></p> <ol style="list-style-type: none"> <li>1. Check the starter configuration and programming record.</li> <li>2. Check motor contactor wiring and voltages at terminal DD1 on the HC-DVR board.</li> <li>3. The TD triac may have failed open. Replace the HC-DVR board.</li> </ol>



Table 6.1 Status and Error Messages

Scrolling Message - Special Event Message
<b>DVR-'n' MTD FAILED TO DEACTIVATE</b> (n = 2 or 3) <i>(Hydro only)</i>
<p><b>Description:</b> The MTD input monitors the status of the TD triac and the TD triac driver. When either fails to deactivate when expected this fault is generated.</p> <p><b>Troubleshooting:</b></p> <ol style="list-style-type: none"> <li>1. Check the starter configuration and programming record.</li> <li>2. Check motor contactor wiring and voltages at terminal DD1 on the HC-DVR board.</li> <li>3. The TD triac may have shorted. Replace the HC-DVR board.</li> </ol>
<b>DVR-'n' MTM FAILED TO ACTIVATE</b> (n = 2 or 3) <i>(Hydro only)</i>
<p><b>Description:</b> The MTM input monitors the status of the TM triac and the TM triac driver. When either fails to activate when expected this fault is generated.</p> <p><b>Troubleshooting:</b></p> <ol style="list-style-type: none"> <li>1. Check the starter configuration and programming record.</li> <li>2. Check motor contactor wiring and voltages at terminal M1 on the HC-DVR board.</li> <li>3. The TM triac may have failed open. Replace the HC-DVR board.</li> </ol>
<b>DVR-'n' MTM FAILED TO DEACTIVATE</b> (n = 2 or 3) <i>(Hydro only)</i>
<p><b>Description:</b> The MTM input monitors the status of the TM triac and the TM triac driver. When either fails to deactivate when expected this fault is generated.</p> <p><b>Troubleshooting:</b></p> <ol style="list-style-type: none"> <li>1. Check the starter configuration and programming record.</li> <li>2. Check motor contactor wiring and voltages at terminal M1 on the HC-DVR board.</li> <li>3. The TM triac may have shorted. Replace the HC-DVR board.</li> </ol>
<b>DVR-'n' MTY FAILED TO ACTIVATE</b> (n = 2 or 3) <i>(Hydro only)</i>
<p><b>Description:</b> The MTY input monitors the status of the TY triac and the TY triac driver. When either fails to activate when expected this fault is generated.</p> <p><b>Troubleshooting:</b></p> <ol style="list-style-type: none"> <li>1. Check the starter configuration and programming record.</li> <li>2. Check motor contactor wiring and voltages at terminal YD1 on the HC-DVR board.</li> <li>3. The TY triac may have failed open. Replace the HC-DVR board.</li> </ol>
<b>DVR-'n' MTY FAILED TO DEACTIVATE</b> (n = 2 or 3) <i>(Hydro only)</i>
<p><b>Description:</b> The MTY input monitors the status of the TY triac and the TY triac driver. When either fails to deactivate when expected this fault is generated.</p> <p><b>Troubleshooting:</b></p> <ol style="list-style-type: none"> <li>1. Check the starter configuration and programming record.</li> <li>2. Check motor contactor wiring and voltages at terminal YD1 on the HC-DVR board.</li> <li>3. The TY triac may have shorted. Replace the HC-DVR board.</li> </ol>
<b>DVR-'n' MUFE FAILED TO ACTIVATE</b> (n = 2 or 3) <i>(Hydro only)</i>
<p><b>Description:</b> The MUFE input monitors the status of the UFE triac and the UFE triac driver. When either fails to activate when expected this fault is generated. When the doors are locked, the 2L bus is high, USL1 and USL2 limits are closed, the up normal limit (UNTD) is closed and the car is idle, terminals UF and UFE should be 120VAC.</p> <p><b>Troubleshooting:</b></p> <ol style="list-style-type: none"> <li>1. Check the associated wiring.</li> <li>2. Check the up fast valve coil.</li> <li>3. Run the car up on inspection and verify that terminal UFE goes low.</li> <li>4. The UFE triac may have failed open. Replace the HC-DVR board.</li> </ol>

**Table 6.1 Status and Error Messages**

Scrolling Message - Special Event Message
<p><b>DVR-'n' MUFE FAILED TO DEACTIVATE</b> (n = 2 or 3) <i>(Hydro only)</i></p> <p><b>Description:</b> The MUFE input monitors the status of the UFE triac and the UFE triac driver. When either fails to deactivate when expected this fault is generated. When the doors are locked, the 2L bus is high, USL1 and USL2 limits are closed, the up normal limit (UNTD) is closed and the car is idle, terminals UF and UFE should be 120VAC.</p> <p><b>Troubleshooting:</b></p> <ol style="list-style-type: none"> <li>1. Check the associated wiring.</li> <li>2. Check the up fast valve coil.</li> <li>3. The UFE triac may have shorted. Replace the HC-DVR board.</li> </ol>
<p><b>DVR-'n' MUSE FAILED TO ACTIVATE</b> (n = 2 or 3) <i>(Hydro only)</i></p> <p><b>Description:</b> The MUSE input monitors the status of the USE triac and the USE triac driver. When either fails to activate when expected this fault is generated. When the doors are locked, the 2L bus is high, USL1 and USL2 limits are closed, the up normal limit (UNTD) is closed and the car is idle, terminals US and USE should be 120VAC.</p> <p><b>Troubleshooting:</b></p> <ol style="list-style-type: none"> <li>1. Check the associated wiring.</li> <li>2. Check the up fast valve coil.</li> <li>3. Run the car up on inspection and verify that terminal USE goes low.</li> <li>4. The USE triac may have failed open. Replace the HC-DVR board.</li> </ol>
<p><b>DVR-'n' MUSE FAILED TO DEACTIVATE</b> (n = 2 or 3) <i>(Hydro only)</i></p> <p><b>Description:</b> The MUSE input monitors the status of the USE triac and the USE triac driver. When either fails to deactivate when expected this fault is generated. When the doors are locked, the 2L bus is high, USL1 and USL2 limits are closed, the up normal limit (UNTD) is closed and the car is idle, terminals US and USE should be 120VAC.</p> <p><b>Troubleshooting:</b></p> <ol style="list-style-type: none"> <li>1. Check the associated wiring.</li> <li>2. Check the up fast valve coil.</li> <li>3. The USE triac may have shorted. Replace the HC-DVR board.</li> </ol>
<p><b>DVR-'n' OLM INPUT FAILURE</b> (n = 2 or 3) <i>(Hydro only)</i></p> <p><b>Description:</b> The OLM input monitors the status of the both the thermal overload and the starter overload contacts. Bus 2L should be 120VAC and relay SAFL should be picked only if the doors are locked. 2MV bus must also be active.</p> <p><b>Troubleshooting:</b></p> <ol style="list-style-type: none"> <li>1. Check that IDC terminal 2L on the HC-CTL board connects to IDC terminal 2L on the HC-DVR board.</li> <li>2. Check the wiring of the thermal overload between terminals TO1 and TO2 on the HC-DVR board.</li> <li>3. Check the wiring of the starter overload between terminal OL1 and OL2 (if present).</li> </ol>
<p><b>DVR-'n' OLM INPUT IS LOW</b> (n = 2 or 3) <i>(Hydro only)</i></p> <p><b>Description:</b> The OLM input monitors the status of the both the thermal overload and the starter overload contacts. Bus 2L should be 120VAC and relay SAFL should be picked only if the doors are locked. 2MV bus must also be active.</p> <p><b>Troubleshooting:</b></p> <ol style="list-style-type: none"> <li>1. Check the wiring of the thermal overload between terminals TO1 and TO2 on the HC-DVR board.</li> <li>2. Check the wiring of the starter overload between terminal OL1 and OL2 (if present).</li> </ol>

Table 6.1 Status and Error Messages

Scrolling Message - Special Event Message
<b>DVR-'n' RP SENSOR TRIPPED</b> (n = 2 or 3) <i>(Hydro only)</i>
<b>Description:</b> The Reverse Phase sensor detected a problem with the incoming power and the RP sensor's N/C contacts activated HC-DVR board (2 or 3) RP1 input (active high - 120VAC). The car returns to the bottom landing, cycles the doors and shuts down. The DOB can cycle the doors. <b>Troubleshooting:</b> <ol style="list-style-type: none"> <li>1. Verify that HC-DVR board (2 or 3) terminal RP1 to ground = 120VAC.</li> <li>2. Check the wiring (phase rotation) to the motor starter.</li> <li>3. Check the wiring to the RP sensor (incorrect, loose or missing wires).</li> </ol>
<b>DVR-'n' STARTER FAULT CONTACT OPEN</b> (n = 2 or 3) <i>(Hydro only)</i>
<b>Description:</b> The solid-state starter internal fault contact is open. <b>Troubleshooting:</b> <ol style="list-style-type: none"> <li>1. Check the solid-state starter fault display screen and refer to the starter manual for troubleshooting instructions.</li> <li>2. Verify that terminal YR1 has 120VAC.</li> </ol>
<b>DVR-'n' STARTER TYPE ERROR</b> (n = 2 or 3) <i>(Hydro only)</i>
<b>Description:</b> The HC-DVR board has received an invalid starter type from the from the MPU board. <b>Troubleshooting:</b> May be caused by a communication error between the HC-MPU and HC-DVR boards, call MCE Tech Support.
<b>DVR-'n' UP NORMAL LIMIT OPEN</b> (n = 2 or 3) <i>(Hydro only)</i>
<b>Description:</b> This message indicates that the car has traveled beyond the top terminal landing and has opened the up normal (directional) terminal switch. <b>Troubleshooting:</b> <ol style="list-style-type: none"> <li>1. Check the location of the car.</li> <li>2. Check the voltage at terminal UNTD.</li> <li>3. Check the limit switch connections.</li> </ol>
<b>DVR-'n' UP TERMINAL LIMIT FAILURE</b> (n = 2 or 3) <i>(Hydro only)</i>
<b>Description:</b> Both the Up Slow Limit and Up Emergency Limit switches have been detected to be in opposite states. These switches should open/close simultaneously, meaning that the voltage at these terminals should always be identical. <b>Troubleshooting:</b> <ol style="list-style-type: none"> <li>1. Check the connections to terminals USL1 and USL2.</li> <li>2. Check the limit switches for proper operation.</li> </ol>
<b>DVR-'n' YRD INPUT FAILURE</b> (n = 2 or 3) <i>(Hydro only)</i>
<b>Description:</b> The Y Contactor Redundancy (YRD) input monitors the normally closed auxiliary contact of the Y starter contactor. <b>Troubleshooting:</b> <ol style="list-style-type: none"> <li>1. The wiring or devices connected to YR1 input may not be terminated.</li> <li>2. Check the Y auxiliary contact wired to terminal YR1 and replace if necessary.</li> <li>3. Check the operation of the Y contactor.</li> </ol>
<b>EARTHQUAKE OPERATION</b>
<b>Description:</b> The EQI and/or CWI input is/are active. The car is on earthquake operation. <b>Troubleshooting:</b> If there has been no seismic activity, check the status of the EQI and CWI inputs. Check the counterweight derailment detection sensor. Check the seismic activity sensor.
<b>ELEVATOR SHUTDOWN SWITCH ACTIVE</b>
<b>Description:</b> The ESS input has been activated. <b>Troubleshooting:</b> Go into Program Mode and see if any of the inputs are programmed as ESS. Then, check to see if that particular input is activated.

**Table 6.1 Status and Error Messages**

Scrolling Message - Special Event Message
<b>EMERGENCY MEDICAL SERVICE</b>
<p><b>Description:</b> Either the EMSH or the EMSC input has been activated.  <b>Troubleshooting:</b> Ensure that the MASSACHUSETTS EMS SERVICE option is set correctly. If not required, set this option to NO and ensure that the EMSH and EMSC inputs are not programmed as spare inputs. If it is required, set this option to the floor that the car should return to when the EMSH input is activated.</p>
<b>EMERGENCY POWER OPERATION</b>
<p><b>Description:</b> The car is on Emergency Power operation (EPI is low).  <b>Troubleshooting:</b> Ensure that the Emergency Power operation option is set correctly. If emergency power is not required, set this option to NO and ensure that the EPI input is not programmed. If it is required, set this option to the floor that the car should return to on Emergency Power and program the EPI input.</p>
<b>ENTER SECURITY CODE</b>
<p><b>Description:</b> MCE Security has been initiated.  <b>Troubleshooting:</b> Enter floor pass code in the C.O.P. within 10 seconds. <a href="#">Please refer to "Building Security Menu" on page 5-59</a> for instructions on how to program or change security passcodes.</p>
<b>EXCESSIVE NUMBER OF FAILED START ATTEMPTS</b>
<p><b>Description:</b> The starter failed to start after three consecutive attempts.  <b>Troubleshooting:</b> Check the fault log to see what faults were generated when attempting to run the starter.</p>
<b>EXMLT INPUT IS ACTIVATED (Hydro only)</b>
<p><b>Description:</b> MLT shutdown with External Motor Limit Timer (EXMLT)  <b>Troubleshooting:</b> Check the External Motor Limit Timer and the associated circuitry. Check the voltage at the EXMLT input. Verify that the wiring is correct. Check the MLT / VLT Data Trap to verify that EXMLT is active.</p>
<b>FIRE SERVICE PHASE 1 - ALTERNATE</b>
<p><b>Description:</b> The car is returning to an alternate fire return landing. The FRS input is low, the FRA input is high or FRAON is active.  <b>Troubleshooting:</b> Inspect the fire sensors (especially the main floor sensor) and the Fire Phase I switch wiring. For some fire codes including ASME, the Fire Phase I switch must be turned to the <i>BYPASS</i> position and then back to <i>OFF</i> to clear the fire service status once activated.</p>
<b>FIRE SERVICE PHASE 1 - MAIN</b>
<p><b>Description:</b> The car is returning to the main fire return landing. The FRS input is low or the FRON or FRON2 inputs are high.  <b>Troubleshooting:</b> Inspect the fire sensors and the Fire Phase I switch wiring. For some fire codes including ASME, the Fire Phase I switch must be turned to the <i>BYPASS</i> position and then back to <i>OFF</i> to clear the fire service status once activated.</p>
<b>FIRE SERVICE PHASE 2</b>
<p><b>Description:</b> The FCS controller input is <i>ON</i>.  <b>Troubleshooting:</b> Inspect the phase 2 switch and wiring. In some cases, to exit Fire Service Phase 2, the car must be at the fire floor at which Fire Phase 2 was activated, the doors must be fully open, and the phase 2 switch must be off (the FCOFF input must be activated) to get out of phase 2.</p>
<b>FRONT DOL AND DLK ARE BOTH ACTIVE</b>
<p><b>Description:</b> A critical failure has caused both the Door Open Limit and Door Lock inputs to both be active at the same time. (DOL=0 &amp; DLK=1). A problem with DOL and/or DLK circuitry or wiring.  <b>Troubleshooting:</b> Inspect the Door Open Limit and the Door Lock circuitry and wiring. When this error is generated, the car will shutdown with the doors open and will not answer any calls. The only way to reset this error condition is to put the car on Inspection operation.</p>

Table 6.1 Status and Error Messages

Scrolling Message - Special Event Message
<b>FRONT DOOR IS LOCKED BUT NOT FULLY CLOSED</b>
<b>Description:</b> Doors Open (DCL = 1) and Locked (DLK = 1). A problem with DCL and/or DLK circuitry or wiring. <b>Troubleshooting:</b> Inspect the Door Closed Limit and the Door Lock circuitry and wiring. When this error is generated, the car is not allowed to run.
<b>FRONT DOOR LOCK SWITCH FAILURE (NYCHA)</b>
<b>Description:</b> The front door lock contacts have failed closed. <b>Troubleshooting:</b> Ensure that with the front hoistway doors closed and locked, there is power on the DLS input and no power present on the DCL input.
<b>FRONT DOOR OPEN LIMIT FAILURE</b>
<b>Description:</b> The door open limit switch has failed open. <b>Troubleshooting:</b> Ensure that the car gate is open, there is no power on the DOL input and no power is present on the DLS or CD inputs.
<b>FRONT GATE SWITCH FAILURE (NYCHA)</b>
<b>Description:</b> The front car gate switch has failed closed. <b>Troubleshooting:</b> Ensure that with the front car gate closed, there is power on the GS input and no power present on the DCL input.
<b>GROUP TO CAR COMMUNICATION LOSS</b>
<b>Description:</b> The car controller has detected a loss of communication with the group controller. <b>Troubleshooting:</b> <ol style="list-style-type: none"> <li>1. Verify that the group controller's MC-MCP board is operating.</li> <li>2. Verify that the SW1 DIP #4 is set to OFF on the group's HC-CHP board (sets baud rate).</li> <li>3. Check the cable between the External Network connector (J4) on the car's HC-MPU board and the External Network connector (J17) on the group's HC-CHP board. Check wiring connections and polarity (CANH, CANL).</li> </ol>
<b>GS INPUT FAILURE (CTLB)</b>
<b>Description:</b> The Gate Switch (GS) input has detected a failure of the ABGA or GBB outputs, DPM, DLAB or the gate switch. <b>Troubleshooting:</b> <ol style="list-style-type: none"> <li>1. Check the gate switch. DPM should activate two inches before the gate switch.</li> <li>2. If GS is active, DLAB must also be active</li> </ol>
<b>GSR INPUT FAILURE (RDRB)</b>
<b>Description:</b> The Rear Gate Switch (GSR) input has detected a failure of the ABGAR or RABA outputs, DPMR, DLABR or the rear gate switch. <b>Troubleshooting:</b> <ol style="list-style-type: none"> <li>1. Check the gate switch. DPMR should activate two inches before the gate switch.</li> <li>2. If GSR is active, DLABR must also be active.</li> </ol>
<b>HALL AND CAR CALL BUSES DISCONNECTED</b>
<b>Description:</b> A problem in the wiring or fuses. There is no power to the call circuits. <b>Troubleshooting:</b> Check the Call Bus fuses. Check the wires that go to the Call Power inputs in the controller.
<b>HALL CALL BUS IS DISCONNECTED</b>
<b>Description:</b> A problem in the wiring or fuses. There is no power to the Hall Call circuits. <b>Troubleshooting:</b> Check the Hall Call Bus fuse. Check the wires that go to the Hall Call Power inputs in the controller.

**Table 6.1 Status and Error Messages**

Scrolling Message - Special Event Message
<b>HEAVY LOAD WEIGHER CONDITION</b>
<p><b>Description:</b> The HLI input has been activated.  <b>Troubleshooting:</b> Go into Program Mode and see if any spare inputs are programmed as an HLI input. Then, check to see if that particular input is activated.</p>
<b>HOISTWAY DOOR BYPASS SW. FAILURE (CTLA)</b>
<p><b>Description:</b> The expected input logic from the HOISTWAY DOOR BYPASS switch has failed.  <b>Troubleshooting:</b></p> <ol style="list-style-type: none"> <li>1. Cycle the HC-CTL board hoistway door bypass switch a few times to exercise it. Verify that it is fully in the ON or OFF position.</li> <li>2. Verify 2S and DLAB connections and wiring.</li> </ol>
<b>HOISTWAY SAFETY DEVICE OPEN</b>
<p><b>Description:</b> One of the hoistway safety devices has activated, opening the safety circuit (e.g., pit stop switch, car and counterweight buffer switches, up/down final limit switches).  <b>Troubleshooting:</b> Check all hoistway safety devices. Refer to controller wiring prints for applicable devices. Verify that the SAFH terminal on the HC-CTL board is powered.</p>
<b>HOSPITAL PHASE 1 OPERATION</b>
<p><b>Description:</b> A hospital emergency momentary call switch is activated at any floor.  <b>Troubleshooting:</b> Ensure that the hospital emergency operation option is set correctly. If hospital emergency operation is not required, set this option to no. If it is required, set the floors eligible to answer a hospital call to yes.</p>
<b>HOSPITAL PHASE 2 OPERATION</b>
<p><b>Description:</b> The car has answered a hospital emergency call or the in car hospital emergency key switch has been activated (HOSP is high).  <b>Troubleshooting:</b> Ensure that the hospital emergency operation option is set correctly. Then check to see if any spare inputs are programmed as HOSP and if it is activated.</p>
<b>ICPD INPUT FAILURE (CTLB)</b>
<p><b>Description:</b> The Car Panel Inspection Down (ICPD) input is high while the 2 bus is low.  <b>Troubleshooting:</b></p> <ol style="list-style-type: none"> <li>1. Check for incorrect wiring or short on the HC-CTL board ICPD input and 2 bus.</li> </ol>
<b>ICPU INPUT FAILURE (CTLB)</b>
<p><b>Description:</b> The Car Panel Inspection Up (ICPU) input is high while the 2 bus is low.  <b>Troubleshooting:</b></p> <ol style="list-style-type: none"> <li>1. Check for incorrect wiring or short on the HC-CTL board ICPU input and 2 bus.</li> </ol>
<b>ICTD INPUT FAILURE (CTLB)</b>
<p><b>Description:</b> The Car Top Inspection Down (ICTD) input is high while the SAFH bus is low.  <b>Troubleshooting:</b></p> <ol style="list-style-type: none"> <li>1. Check for incorrect wiring or short on the HC-CTL board ICTD input.</li> </ol>
<b>ICTU INPUT FAILURE (CTLB)</b>
<p><b>Description:</b> The Car Top Inspection Up (ICTU) input is high while the SAFH bus is low.  <b>Troubleshooting:</b></p> <ol style="list-style-type: none"> <li>1. Check for incorrect wiring or short on the HC-CTL board ICTU input.</li> </ol>
<b>INA INPUT FAILURE (CTLA)</b>
<p><b>Description:</b> The INA input to the microcontroller did not receive a signal when expected.  <b>Troubleshooting:</b></p> <ol style="list-style-type: none"> <li>1. Check for incorrect wiring or short on the HC-CTL board INA input and 2 bus.</li> <li>2. Check access enable switch in COP and connection through traveler.</li> </ol>

**Table 6.1 Status and Error Messages**

Scrolling Message - Special Event Message
<b>IN-CAR INSPECTION (CTLA)</b>
<b>Description:</b> The controller is currently on IN-CAR inspection, activated by 120VAC at screw terminal INCP on the HC-CTL board.
<b>IN CAR STOP SWITCH ACTIVATED</b>
<b>Description:</b> The in-car stop switch has been pulled, opening the safety circuit. <b>Troubleshooting:</b> Check the status of the in-car emergency stop switch.
<b>INCP INPUT FAILURE (CTLA)</b>
<b>Description:</b> The Car Panel Inspection INSP/Auto Switch input (INCP) is high while the 2 bus is low. <b>Troubleshooting:</b> 1. Check for incorrect wiring or short on the HC-CTL board INCP input and 2 bus.
<b>INCT INPUT FAILURE (CTLA)</b>
<b>Description:</b> The Car Top Inspection INSP/AUTO Switch input (INCT) is high while SAFH is low. <b>Troubleshooting:</b> 1. Check for incorrect wiring or short on the HC-CTL board INCT input and SAFH or 2 bus.
<b>INDEPENDENT SERVICE OPERATION</b>
<b>Description:</b> The Independent Service switch inside the car has been turned on. <b>Troubleshooting:</b> Check the Independent Service switch inside the car.
<b>INSPECTION DIRECTION SW. FAILURE (CTLB)</b>
<b>Description:</b> Both UP and DN Machine Room Inspection directions are activated at the same time. <b>Troubleshooting:</b> 1. Exercise the HT-CTL board Inspection direction switch. Verify that it remains in the middle when released. 2. Check status of UP and DOWN indicator LEDs.
<b>INSPECTION OPERATION</b>
<b>Description:</b> The car is on Inspection operation. <b>Troubleshooting:</b> Check all of the inspection switches and associated wiring.
<b>LANDING SYSTEM REDUNDANCY FAILURE (Non ASME-2000)</b>
<b>Description:</b> Either DZ, LU or LD has failed closed. <b>Troubleshooting:</b> Ensure that on any run between floors, the LSR input goes low at least once. If the DZ sensor has failed closed, power will be present continuously on the LSR input. If either the LU or LD sensor has failed closed, power will be present constantly on their respective inputs and this can also cause this error. This condition can be cleared by pressing the Redundancy Reset button.
<b>LEVELING DOWN</b>
<b>Description:</b> The Level Down computer input is <i>ON</i> . Comes <i>ON</i> normally when the car is just above a floor. If the car is level with the floor and a message appears, it is usually the result of a switch or sensor problem. <b>Troubleshooting:</b> Inspect the LD switch or sensor on the landing system and the placement of the landing system vane or magnet for that floor.

**Table 6.1 Status and Error Messages**

Scrolling Message - Special Event Message
<b>LEVELING SENSOR FAILED - OFF POSITION</b>
<p><b>Description:</b> One of the leveling sensor inputs (LU or LD) appears to have failed (in the inactive state). The controller computer did not detect the appropriate leveling signal (LU or LD) during the last approach to the floor. Probable causes may be:</p> <ol style="list-style-type: none"> <li>1. A faulty leveling sensor or associated circuitry (within the landing system assembly);</li> <li>2. Faulty wiring from the landing system to the controller;</li> <li>3. Faulty computer input circuit (HC-CTL Control board).</li> </ol> <p><b>Troubleshooting:</b> Check operation of the leveling sensors and associated wiring (place car on inspection, move above and below a landing, noting the transitions in the leveling signal(s) coming from the landing system). Verify that the computer diagnostic display of LU and LD matches the state of the sensor signals at the main relay board.</p>
<b>LEVELING SENSOR FAILED - ON POSITION</b>
<p><b>Description:</b> One of the leveling sensor inputs (LU or LD) appears to have failed (in the active state). The controller computer detected that both the LU and LD inputs are active simultaneously. Probable causes may be:</p> <ol style="list-style-type: none"> <li>1. A faulty leveling sensor or associated circuitry (within the landing system assembly);</li> <li>2. Faulty wiring from the landing system to the controller;</li> <li>3. Faulty computer input circuit (HC-CTL Control board).</li> </ol> <p><b>Troubleshooting:</b> Check operation of the leveling sensors and associated wiring (place car on inspection, move above and below a landing, noting the transitions in the leveling signal(s) coming from the landing system). Verify that the computer diagnostic display of LU and LD matches the state of the sensor signals at the main relay board. Check also the operation of any contacts that may be placed at the "low side" (the "1-bus" side) of the LU and LD relay coils (e.g., H, INT). Check that such contacts close properly when appropriate.</p>
<b>LEVELING SENSOR FAILURE</b>
<p><b>Description:</b> One or both of the LU and LD sensors have failed closed. <b>Troubleshooting:</b> Ensure that power is not present on both the LU and LD inputs.</p>
<b>LEVELING UP</b>
<p><b>Description:</b> The Level Up computer input is <i>ON</i>. Comes <i>ON</i> normally when the car is just below a floor. If the car is level with the floor and a message appears, it is usually the result of a switch or sensor problem. <b>Troubleshooting:</b> Inspect the LU switch or sensor on the landing system and the placement of the landing system vane or magnet for that floor.</p>
<b>LIGHT LOAD WEIGHER CONDITION</b>
<p><b>Description:</b> The Light Load Weighing input is activated. <b>Troubleshooting:</b> Ensure that Light Load Weighing is required. If not, set the Light Load Weighing option to NO and ensure that the LLI input is not programmed. If Light Load Weighing is required, ensure that the Light Load Car Call Limit is set to the correct number of stops.</p>
<b>LOSS OF DOOR LOCK OUT OF DOOR ZONE</b>
<p><b>Description:</b> Door lock lost with elevator outside of door zone (i.e., outside of door zone and leveling). May also be generated at speed if the door locks are clipped. <b>Troubleshooting:</b> Inspect door lock circuitry and wiring. Check for any mechanical contact with gate switch or door clutch (if restrictor used) and hoistway components.</p>
<b>LOW OIL SWITCH INPUT IS ACTIVATED</b> <i>(Hydro only)</i>
<p><b>Description:</b> MLT shutdown with LOS. The car was unable to move at the expected speed due to insufficient oil. <b>Troubleshooting:</b> Check the MLT/VLT Data Trap (Addr 0495H bit 8). Ensure that there is sufficient oil in the reservoir. Check the Low Oil switch and LOS input.</p>



**Table 6.1 Status and Error Messages**

Scrolling Message - Special Event Message
<p><b>M2L INPUT FAILURE</b></p> <p><b>Description:</b> The M2L input monitors the status of the relay contacts of SAFL and SAFS against the circuits that drive these relay coils. Bus 2L should be 120VAC and relay SAFL should be picked only if the doors are locked. 2MV bus must also be active.</p> <p><b>Troubleshooting:</b></p> <ol style="list-style-type: none"> <li>1. Check or replace relays SAFL and/or SAFS on the HC-CTL board.</li> <li>2. Verify that IDC terminal 2L on the HC-CTL board connects to IDC terminal 2L on the HC-DVR board.</li> <li>3. Check the thermal overload wiring between terminals TO1 and TO2 on the HC-DVR board.</li> <li>4. Check the wiring of the starter overload between terminal OL1 and OL2 (if present).</li> </ol>
<p><b>MABB INPUT FAILURE (CTLA)</b></p> <p><b>Description:</b> The Bottom Access Bypass Monitor (door close contacts) (MABB) input monitors proper operation of the solid state devices associated with bypassing the bottom hoistway door contacts during access operation.</p> <p><b>Troubleshooting:</b> Remove the car from access operation and verify that test point TP41 (MABB) on the HC-CTL board is low with respect to 1 bus.</p>
<p><b>MABBR INPUT FAILURE (RDRA)</b></p> <p><b>Description:</b> The Bottom Rear Access Monitor (door close contacts) (MABBR) input monitors proper operation of the solid state devices associated with bypassing the bottom rear hoistway door contacts during access operation.</p> <p><b>Troubleshooting:</b> Remove the car from access operation and verify that test point TP43 (MABBR) on the HC-RDR board is low with respect to 1 bus.</p>
<p><b>MABGF INPUT FAILURE (CTLB)</b></p> <p><b>Description:</b> The Front Access Gate Bypass Monitor (MABGF) input has detected a failure of the Access Bypass Gate A (ABGA) or Front Access Bypass Bottom (FABB) outputs.</p> <p><b>Troubleshooting:</b></p> <ol style="list-style-type: none"> <li>1. Temporarily disconnect then reconnect the CAN connection to the HC-CTL board to reset the microprocessors.</li> <li>2. Verify that SPA, SPB, and SPC LEDs are all lighted.</li> <li>3. If this failure occurred while updating software, refer to the update instructions and repeat the process.</li> </ol>
<p><b>MABGR INPUT FAILURE (RDRB)</b></p> <p><b>Description:</b> The Rear Access Gate Bypass Monitor (MABGR) input has detected a failure of the Rear Access Bypass Gate A (ABGAR) or Rear Access Bypass (RABA) outputs.</p> <p><b>Troubleshooting:</b></p> <ol style="list-style-type: none"> <li>1. Temporarily disconnect then reconnect the CAN connection to the HC-RDR board to reset the microprocessors.</li> <li>2. Verify that SPA and SPB LEDs are lighted.</li> <li>3. If this failure occurred while updating software, refer to the update instructions and repeat the process.</li> </ol>
<p><b>MABT INPUT FAILURE (CTLB)</b></p> <p><b>Description:</b> The Top Access Bypass Monitor (door close contacts) (MABT) input monitors proper operation of the solid state devices associated with bypassing the top hoistway door contacts during access operation.</p> <p><b>Troubleshooting:</b> Remove the car from access operation and verify that test point TP33 (MABT) on the HC-CTL board is low with respect to 1 bus.</p>

**Table 6.1 Status and Error Messages**

Scrolling Message - Special Event Message
<b>MABTR INPUT FAILURE</b>
<p><b>Description:</b> The Top Rear Access Bypass Monitor (MABTR) input monitors proper operation of the solid state devices associated with bypassing the top rear hoistway door contacts during access operation.</p> <p><b>Troubleshooting:</b> Remove the car from access operation and verify that test point TP42 (MABTR) on the HC-RDR board is low with respect to 1 bus.</p>
<b>MACHINE ROOM INSPECTION (CTLA)</b>
<p><b>Description:</b> The controller is currently in MACHINE ROOM inspection operation.</p>
<b>MBAB INPUT FAILURE (CTLB)</b>
<p><b>Description:</b> The Bottom Access Bypass Monitor (door lock contacts) (MBAB) input has detected a failure of the Bottom Access Bypass (BAB) or (BABA) outputs or the BAB input.</p> <p><b>Troubleshooting:</b></p> <ol style="list-style-type: none"> <li>1. Check the wiring at HC-CTL board terminal BAB.</li> </ol>
<b>MBABR INPUT FAILURE (RDRB)</b>
<p><b>Description:</b> The Bottom Rear Access Bypass monitor (door lock contacts) (MBABR) input has detected a failure of the Bottom Rear Access Bypass (BABR) or (BABAR) outputs or the BABR input.</p> <p><b>Troubleshooting:</b></p> <ol style="list-style-type: none"> <li>1. Check the wiring at HC-RDR board terminal BABR.</li> <li>2. Check Access switches and proper wiring of the access terminals (ABU, ABD).</li> </ol>
<b>MCSB INPUT FAILURE (CTLA)</b>
<p><b>Description:</b> The Car Stop Bypass Monitor (MCSB) input on the HC-CTL board is active while the car stop bypass circuit is not active.</p> <p><b>Troubleshooting:</b></p> <ol style="list-style-type: none"> <li>1. Verify wiring and connections at ESC and SAFC.</li> <li>2. Temporarily disconnect then reconnect the CAN connection to the HC-CTL board to reset the microprocessors.</li> <li>3. Verify that SPA, SPB, and SPC LEDs are all lighted.</li> <li>4. If this failure occurred while updating software, refer to the update instructions and repeat the process.</li> </ol>
<b>MDFE FAILED TO ACTIVATE (Hydro only)</b>
<p><b>Description:</b> The MDFE input monitors the status of the DFE triac and the DFE triac driver. When either fails to activate when expected this fault is generated. When the doors are locked, the 2L bus is high, DSL1 and DSL2 limits are closed, the down normal limit (DNTD) is closed and the car is idle, terminals DF and DFE should 120VAC.</p> <p><b>Troubleshooting:</b></p> <ol style="list-style-type: none"> <li>1. Check the associated wiring.</li> <li>2. Check the down fast valve coil.</li> <li>3. Run the car down on inspection and verify that terminal DFE goes low.</li> <li>4. The DFE triac may have failed open. Replace the HC-DVR board.</li> </ol>
<b>MDFE FAILED TO DEACTIVATE (Hydro only)</b>
<p><b>Description:</b> The MDFE input monitors the status of the DFE triac and the DFE triac driver. When either fails to deactivate when expected this fault is generated. When the doors are locked, the 2L bus is high, DSL1 and DSL2 limits are closed, the down normal limit (DNTD) is closed and the car is idle, terminals DF and DFE should 120VAC.</p> <p><b>Troubleshooting:</b></p> <ol style="list-style-type: none"> <li>1. Check the associated wiring.</li> <li>2. Check the down fast valve coil.</li> <li>3. The DFE triac may have shorted. Replace the HC-DVR board.</li> </ol>

Table 6.1 Status and Error Messages

Scrolling Message - Special Event Message
<b>MDFE INPUT IS LOW</b> (CTLB) <i>(Hydro only)</i>
<p><b>Description:</b> The input that monitors the continuity of the DN Fast Valve coil and also checks the off state of the (DFE) triac.</p> <p><b>Troubleshooting:</b></p> <ol style="list-style-type: none"> <li>1. Check the termination of the valve coil at terminal DFE on the HC-DVR board.</li> <li>2. Check terminal DF for 120VAC with respect to 1 bus.</li> </ol>
<b>MDSE FAILED TO ACTIVATE</b> <i>(Hydro only)</i>
<p><b>Description:</b> The MDSE input monitors the status of the DSE triac and the DSE triac driver. When either fails to activate when expected this fault is generated. When the doors are locked, the 2L bus is high, the down normal limit (DNTD) is closed and the car is idle, terminals DS and DSE should 120VAC.</p> <p><b>Troubleshooting:</b></p> <ol style="list-style-type: none"> <li>1. Check the associated wiring.</li> <li>2. Check the down slow valve coil.</li> <li>3. Run the car down on inspection and verify that terminal DSE goes low.</li> <li>4. The DSE triac may have failed open. Replace the HC-DVR board.</li> </ol>
<b>MDSE FAILED TO DEACTIVATE</b> <i>(Hydro only)</i>
<p><b>Description:</b> The MDSE input monitors the status of the DSE triac and the DSE triac driver. When either fails to deactivate when expected this fault is generated. When the doors are locked, the 2L bus is high, the down normal limit (DNTD) is closed and the car is idle, terminals DS and DSE should 120VAC.</p> <p><b>Troubleshooting:</b></p> <ol style="list-style-type: none"> <li>1. Check the associated wiring.</li> <li>2. Check the down slow valve coil.</li> <li>3. The DSE triac may have shorted. Replace the HC-DVR board.</li> </ol>
<b>MDSE INPUT IS LOW</b> (CTLA) <i>(Hydro only)</i>
<p><b>Description:</b> The MDSE input monitors the continuity of the DN Slow Valve coil and also checks the OFF state of the DSE triac.</p> <p><b>Troubleshooting:</b></p> <ol style="list-style-type: none"> <li>1. Check the termination of the valve coil at terminal DSE on the HC-DVR board.</li> <li>2. Check terminal DS for 120VAC with respect to 1 bus.</li> </ol>
<b>MDZLV INPUT FAILURE</b> (CTLB)
<p><b>Description:</b> The Door Zone/Leveling Monitor (MDZLV) input has detected a failure of the Door Zone/Leveling (DZLV) or (DZLVA) outputs or failure of the normally open DZ relay.</p> <p><b>Troubleshooting:</b></p> <ol style="list-style-type: none"> <li>1. Replace relay DZ.</li> </ol>
<b>MGB INPUT FAILURE</b> (CTLA)
<p><b>Description:</b> A failure of the gate switch bypass circuit has been detected.</p> <p><b>Troubleshooting:</b></p> <ol style="list-style-type: none"> <li>1. Toggle the gate bypass switch on the HC-CTL board a few times, then make certain it is fully in the ON or OFF position.</li> <li>2. Briefly disconnect then reconnect CAN connection to CTL board to reset processors.</li> </ol>
<b>MGBR INPUT FAILURE</b> (RDRA)
<p><b>Description:</b> A failure of the rear gate switch bypass circuit has been detected.</p> <p><b>Troubleshooting:</b></p> <ol style="list-style-type: none"> <li>1. Toggle the gate bypass switch on the HC-RDR board a few times, then make certain it is fully in the ON or OFF position.</li> <li>2. Briefly disconnect then reconnect CAN connection to RDR board to reset processors.</li> </ol>

**Table 6.1 Status and Error Messages**

Scrolling Message - Special Event Message
<p><b>MGS INPUT FAILURE (CTLA)</b></p> <p><b>Description:</b> The Gate Switch Monitor (MGS) input has detected a failure of the gate switch or Door Zone/Door Zone Leveling (DZ/DZLVA) circuitry.</p> <p><b>Troubleshooting:</b></p> <ol style="list-style-type: none"> <li>1. Check the condition of the gate switch.</li> <li>2. Replace relay GS.</li> <li>3. Replace relay DZ.</li> <li>4. Check continuity between IDC terminals GS1 and GS2 on the HC-CTL board.</li> <li>5. If rear doors are present, check GSR.</li> <li>6. Replace the HC-CTL board.</li> </ol>
<p><b>MGSR INPUT FAILURE (RDRA) (CTLA)</b></p> <p><b>Description:</b> The Rear Gate Switch Monitor (MGSR) input (test point TP48 (GSR2) on the HC-RDR board) has detected a failure of the rear gate switch or Door Zone/Door Zone Leveling (DZ/DZLVA) circuitry.</p> <p><b>Condition 1:</b> MGSR should be low during automatic operation when either the rear gate or rear hoistway doors are open as indicated by the GSR and DLR relays, except during re-leveling.</p> <p><b>Troubleshooting:</b></p> <ol style="list-style-type: none"> <li>1. If either relay GSR or DLR is not picked, verify that TP48 is low.</li> <li>2. Check continuity between terminals GS1 on the HC-CTL and GSR1 on the HC-RDR board and between terminals GS2 on the HC-CTL and GSR2 on the HC-RDR board.</li> </ol> <p><b>Condition 2:</b> If the car is re-leveling, and the front doors are closed, the MGSR input should have 120VAC.</p> <p><b>Troubleshooting:</b> Check continuity between terminals GS2 on the HC-CTL and GSR2 on the HC-RDR board.</p> <p><b>Condition 3:</b> This fault is also generated if relays GSR and DLR are picked indicating that the rear gate and hoistway doors are closed, but the MGSR input is low.</p> <p><b>Troubleshooting:</b></p> <ol style="list-style-type: none"> <li>1. Verify that both relays DLR and GSR are picked.</li> <li>2. Verify 120VAC on terminals GSR1 and GSR2.</li> <li>3. Verify 120VAC on TP49 (MDLR) on the HC-RDR board.</li> <li>4. Verify 120VAC on TP48 (GSR2) on the HC-RDR board.</li> </ol>
<p><b>MHDB INPUT FAILURE (CTLB)</b></p> <p><b>Description:</b> The Hoistway Door Bypass Monitor (MHDB) input has detected a failure of the Hoistway Door Bypass (HDB) or (HDBA) outputs.</p> <p><b>Troubleshooting:</b></p> <ol style="list-style-type: none"> <li>1. Toggle the door bypass switch on the HC-CTL board a few times, then make certain it is fully in the ON or OFF position.</li> <li>2. Briefly disconnect then reconnect CAN connection to CTL board to reset processors.</li> </ol>
<p><b>MHDBR INPUT FAILURE (RDRB)</b></p> <p><b>Description:</b> The Rear Hoistway Door Bypass Monitor (MHDBR) input has detected a failure of the Rear Hoistway Door Bypass (HDBR) or (HDBBR) outputs.</p> <p><b>Troubleshooting:</b></p> <ol style="list-style-type: none"> <li>1. Toggle the door bypass switch on the HC-RDR board a few times, then make certain it is fully in the ON or OFF position.</li> <li>2. Briefly disconnect then reconnect CAN connection to RDR board to reset processors.</li> </ol>
<p><b>MOTOR LIMIT TIMER (ANTI-STALL) ELAPSED</b></p> <p><b>Description:</b> The Starter Overload or the Thermal Overload has tripped, or there is a mechanical problem that prevents or slows the motion of the car.</p> <p><b>Troubleshooting:</b> To clear the condition, the car must be put on Inspection, then back into Normal operation, or the RESET button must be pressed. Immediately check the starter and thermal overloads and all circuitry associated with the motor.</p>

**Table 6.1 Status and Error Messages**

Scrolling Message - Special Event Message
<b>MPI SPA IS OFFLINE, MPI SPB IS OFFLINE, MPI SPC IS OFF LINE</b>
<p><b>Description:</b> These messages are Motion 4000 Traction related.</p> <p><b>Troubleshooting:</b> Verify that CONTROLLER TYPE in the PROGRAM MODE (F1) BASIC FEATURES MENU is set to HYDRO (M2000).</p>
<b>MRD INPUT FAILURE</b>
<p><b>Description:</b> The M Contactor Redundancy (MRD) input monitors the normally closed auxiliary contact of the M contactor.</p> <p><b>Troubleshooting:</b></p> <ol style="list-style-type: none"> <li>1. The wiring or devices connected to MR1 input may not be terminated.</li> <li>2. Check the M auxiliary contact wired to terminal MR1 and replace if necessary.</li> <li>3. Check the operation of the M contactor.</li> </ol>
<b>MSAFL1 INPUT FAILURE (CTLB)</b>
<p><b>Description:</b> The MSAFL1 input monitors the status of the relay contacts of SAFL and SAFS against the circuits that drive these relay coils. Bus 2L should be 120 Vac and relay SAFL should be picked only if the doors are locked.</p> <ul style="list-style-type: none"> <li>• This fault is generated if test point 2L, on the HC-CTL board, measures 120VAC to ground while one of the following is true: <ol style="list-style-type: none"> <li>1. Test point SAFLA is 0VAC</li> <li>2. Test point SAFLB is 120VAC</li> <li>3. Test point MGS, on the HC-CTL board, is 0VAC</li> <li>4. Test point MSAFS1 is 0VAC</li> <li>5. Safety bus terminal 2S, on the HC-CTL board, is 0VAC</li> <li>6. 2MVM, IDC on the HC-CTL board, is 0VAC.</li> </ol> </li> <li>• This fault is also generated if test point 2L, on the HC-CTL board, measures 0VAC and 2MVM, IDC on the HC-CTL board, is 120VAC to ground while all of the following are true: <ol style="list-style-type: none"> <li>1. Safety bus terminal 2S, on the HC-CTL board input, is 120VAC</li> <li>2. Test point MGS is 120VAC</li> <li>3. Test point MSAFS1 is 120VAC</li> <li>4. Test point SAFLA is 120VAC</li> <li>5. Test point SAFLB is 0VAC.</li> </ol> </li> </ul> <p><b>Troubleshooting:</b></p> <ol style="list-style-type: none"> <li>1. Check or replace relays SAFL and/or SAFS on the HC-CTL board.</li> <li>2. Check that IDC terminal 2L on the HC-CTL board connects to IDC terminal 2L on the HC-DVR board.</li> <li>3. Check the wiring of the thermal overload between terminals TO1 and TO2 on the HC-DVR board.</li> <li>4. Check the wiring of the starter overload between terminal OL1 and OL2 (if present).</li> <li>5. Replace the HC-CTL board.</li> </ol>
<b>MSAFS1 INPUT FAILURE (CTLA)</b>
<p><b>Description:</b> The MSAFS1 input monitors the status of the relay contacts of SAFL and SAFS against the circuits that drive these relay coils. Relay SAFS should be picked only if the safety string is made.</p> <p><b>Troubleshooting:</b></p> <ol style="list-style-type: none"> <li>1. Check or replace relays SAFL and/or SAFS on the HC-CTL board.</li> <li>2. Check wiring associated with screw terminals SAFH, SAFC and ESC.</li> </ol>
<b>MSSD FAILED ACTIVE (CTLB)</b>
<p><b>Description:</b> MSSD monitors the solid state output of U1 and driver TY for proper operation. If either fail in the on position this fault is generated.</p> <p><b>Troubleshooting:</b></p> <ol style="list-style-type: none"> <li>1. Check terminal SSD wiring.</li> </ol>

**Table 6.1 Status and Error Messages**

Scrolling Message - Special Event Message
<b>MSSD FAILED TO ACTIVATE</b>
<p><b>Description:</b> MSSD monitors the solid state output of U1 and driver TY for proper operation. If either fail in the off position this fault is generated. When terminal OL2 is 120VAC and the car is commanded to run up, terminal SSD should be 120VAC.</p> <p><b>Troubleshooting:</b></p> <ol style="list-style-type: none"> <li>1. Check the wiring at terminal SSD and OL2.</li> </ol>
<b>MSSD FAILED TO DEACTIVATE</b>
<p><b>Description:</b> MSSD monitors the solid state output of U1 and driver TY for proper operation. If either fail in the on position this fault is generated. When either fails to deactivate when expected this fault is generated. When the OL2 is 120VAC and the car is idle, terminal SSD should be low.</p> <p><b>Troubleshooting:</b></p> <ol style="list-style-type: none"> <li>1. Check terminal SSD wiring.</li> </ol>
<b>MTAB INPUT FAILURE (CTLB)</b>
<p><b>Description:</b> The Top Access Bypass Monitor (MTAB) input has detected a failure of the Top Access Bypass (TAB) or (TABA) outputs.</p> <p><b>Troubleshooting:</b></p> <ol style="list-style-type: none"> <li>1. Verify wiring at HC-CTL board terminals TAB and DLAT.</li> <li>2. Check access switches and proper wiring of access terminals ATU, ATD.</li> </ol>
<b>MTABR INPUT FAILURE (RDRB)</b>
<p><b>Description:</b> The Top Rear Access Monitor (MTABR) input has detected a failure of the Top Rear Access Bypass (TABR) or (TABAR) outputs or the TABR input.</p> <p><b>Troubleshooting:</b></p> <ol style="list-style-type: none"> <li>1. Check the wiring at HC-RDR board terminal TABR.</li> <li>2. Check Access switches and proper wiring of the access terminals (ATU, ATD).</li> </ol>
<b>MTD FAILED TO ACTIVATE (Hydro only)</b>
<p><b>Description:</b> The MTD input monitors the status of the TD triac and the TD triac driver. When either fails to activate when expected this fault is generated.</p> <p><b>Troubleshooting:</b></p> <ol style="list-style-type: none"> <li>1. Check the starter configuration and programming record.</li> <li>2. Check motor contactor wiring and voltages at terminal DD1 on the HC-DVR board.</li> <li>3. The TD triac may have failed open. Replace the HC-DVR board.</li> </ol>
<b>MTD FAILED TO DEACTIVATE (Hydro only)</b>
<p><b>Description:</b> The MTD input monitors the status of the TD triac and the TD triac driver. When either fails to deactivate when expected this fault is generated.</p> <p><b>Troubleshooting:</b></p> <ol style="list-style-type: none"> <li>1. Check the starter configuration and programming record.</li> <li>2. Check motor contactor wiring and voltages at terminal DD1 on the HC-DVR board.</li> <li>3. The TD triac may have shorted. Replace the HC-DVR board.</li> </ol>
<b>MTD INPUT FAILURE (CTLA) (Hydro only)</b>
<p><b>Description:</b> The input monitors the continuity of the DEL contactor coil and also checks the OFF state of the (TD) triac.</p> <p><b>Troubleshooting:</b></p> <ol style="list-style-type: none"> <li>1. Verify that the STARTER #1 TYPE parameter is set to the correct type, WYE-DELTA or ACROSS THE LINE.</li> <li>2. Check the termination of the left hand DEL contactor coil at terminal DD1 on the HC-DVR board.</li> <li>3. Check the normally closed auxiliary contact of Y that feeds the right hand coil of DEL.</li> </ol>

**Table 6.1 Status and Error Messages**

Scrolling Message - Special Event Message
<b>MTM FAILED TO ACTIVATE</b> <i>(Hydro only)</i>
<p><b>Description:</b> The MTM input monitors the status of the TM triac and the TM triac driver. When either fails to activate when expected this fault is generated.</p> <p><b>Troubleshooting:</b></p> <ol style="list-style-type: none"> <li>1. Check the starter configuration and programming record.</li> <li>2. Check motor contactor wiring and voltages at terminal M1 on the HC-DVR board.</li> <li>3. The TM triac may have failed open. Replace the HC-DVR board.</li> </ol>
<b>MTM FAILED TO DEACTIVATE</b> <i>(Hydro only)</i>
<p><b>Description:</b> The MTM input monitors the status of the TM triac and the TM triac driver. When either fails to deactivate when expected this fault is generated.</p> <p><b>Troubleshooting:</b></p> <ol style="list-style-type: none"> <li>1. Check the starter configuration and programming record.</li> <li>2. Check motor contactor wiring and voltages at terminal M1 on the HC-DVR board.</li> <li>3. The TM triac may have shorted. Replace the HC-DVR board.</li> </ol>
<b>MTM INPUT FAILURE</b> (CTLA) <i>(Hydro only)</i>
<p><b>Description:</b> The input monitors the continuity of the M contactor coil and also checks the OFF state of the (TM) triac.</p> <p><b>Troubleshooting:</b></p> <ol style="list-style-type: none"> <li>1. Verify that the M CONTACTOR INSTALLED parameter has been set to YES (if present).</li> <li>2. Check the contactor coil.</li> <li>3. Check the termination of the left hand M contactor coil at terminal M1 on the HC-DVR board.</li> </ol>
<b>MTY FAILED TO ACTIVATE</b> <i>(Hydro only)</i>
<p><b>Description:</b> The MTY input monitors the status of the TY triac and the TY triac driver. When either fails to activate when expected this fault is generated.</p> <p><b>Troubleshooting:</b></p> <ol style="list-style-type: none"> <li>1. Check the starter configuration and programming record.</li> <li>2. Check motor contactor wiring and voltages at terminal YD1 on the HC-DVR board.</li> <li>3. The TY triac may have failed open. Replace the HC-DVR board.</li> </ol>
<b>MTY FAILED TO DEACTIVATE</b> <i>(Hydro only)</i>
<p><b>Description:</b> The MTY input monitors the status of the TY triac and the TY triac driver. When either fails to deactivate when expected this fault is generated.</p> <p><b>Troubleshooting:</b></p> <ol style="list-style-type: none"> <li>1. Check the starter configuration and programming record.</li> <li>2. Check motor contactor wiring and voltages at terminal YD1 on the HC-DVR board.</li> <li>3. The TY triac may have shorted. Replace the HC-DVR board.</li> </ol>
<b>MTY INPUT FAILURE</b> <i>(Hydro only)</i>
<p><b>Description:</b> The input monitors the continuity of the Y Contactor coil and also checks the OFF state of the (TY) triac.</p> <p><b>Troubleshooting:</b></p> <ol style="list-style-type: none"> <li>1. Verify that the STARTER #1 TYPE parameter is set to the correct type, WYE-DELTA.</li> <li>2. Check the termination of the left hand Y contactor coil at terminal YD1 on the HC-DVR board.</li> <li>3. Check the normally closed auxiliary contact of DEL that feeds the right hand coil of Y.</li> </ol>

**Table 6.1 Status and Error Messages**

Scrolling Message - Special Event Message
<b>MUFE FAILED TO ACTIVATE</b> <i>(Hydro only)</i>
<p><b>Description:</b> The MUFE input monitors the status of the UFE triac and the UFE triac driver. When either fails to activate when expected this fault is generated. When the doors are locked, the 2L bus is high, USL1 and USL2 limits are closed, the up normal limit (UNTD) is closed and the car is idle, terminals UF and UFE should be 120VAC.</p> <p><b>Troubleshooting:</b></p> <ol style="list-style-type: none"> <li>1. Check the associated wiring.</li> <li>2. Check the up fast valve coil.</li> <li>3. Run the car up on inspection and verify that terminal UFE goes low.</li> <li>4. The UFE triac may have failed open. Replace the HC-DVR board.</li> </ol>
<b>MUFE FAILED TO DEACTIVATE</b> <i>(Hydro only)</i>
<p><b>Description:</b> The MUFE input monitors the status of the UFE triac and the UFE triac driver. When either fails to deactivate when expected this fault is generated. When the doors are locked, the 2L bus is high, USL1 and USL2 limits are closed, the up normal limit (UNTD) is closed and the car is idle, terminals UF and UFE should be 120VAC.</p> <p><b>Troubleshooting:</b></p> <ol style="list-style-type: none"> <li>1. Check the associated wiring.</li> <li>2. Check the up fast valve coil.</li> <li>3. The UFE triac may have shorted. Replace the HC-DVR board.</li> </ol>
<b>MUFE INPUT IS LOW</b> (CTLB) <i>(Hydro only)</i>
<p><b>Description:</b> The MUFE input monitors the continuity of the Up Fast Valve coil and also checks the OFF state of the UFE triac.</p> <p><b>Troubleshooting:</b></p> <ol style="list-style-type: none"> <li>1. Check the termination of the valve coil at terminal UFE on the HC-DVR board.</li> <li>2. Check terminal UF for 120VAC with respect to 1 bus.</li> </ol>
<b>MUSE FAILED TO ACTIVATE</b> <i>(Hydro only)</i>
<p><b>Description:</b> The MUSE input monitors the status of the USE triac and the USE triac driver. When either fails to activate when expected this fault is generated. When the doors are locked, the 2L bus is high, USL1 and USL2 limits are closed, the up normal limit (UNTD) is closed and the car is idle, terminals US and USE should be 120VAC.</p> <p><b>Troubleshooting:</b></p> <ol style="list-style-type: none"> <li>1. Check the associated wiring.</li> <li>2. Check the up fast valve coil.</li> <li>3. Run the car up on inspection and verify that terminal USE goes low.</li> <li>4. The USE triac may have failed open. Replace the HC-DVR board.</li> </ol>
<b>MUSE FAILED TO DEACTIVATE</b> <i>(Hydro only)</i>
<p><b>Description:</b> The MUSE input monitors the status of the USE triac and the USE triac software output. When USE fails to deactivate when expected this fault is generated. When the doors are locked, the 2L bus is high, USL1 and USL2 limits are closed, the up normal limit (UNTD) is closed and the car is idle, terminals US and USE should be 120VAC.</p> <p><b>Troubleshooting:</b></p> <ol style="list-style-type: none"> <li>1. Check the associated wiring.</li> <li>2. Check the up fast valve coil.</li> <li>3. The USE triac may have shorted. Replace the HC-DVR board.</li> </ol>
<b>MUSE INPUT IS LOW</b> (CTLA) <i>(Hydro only)</i>
<p><b>Description:</b> The MUSE input monitors the continuity of the Up Slow Valve coil and also checks the OFF state of the USE triac.</p> <p><b>Troubleshooting:</b></p> <ol style="list-style-type: none"> <li>1. Check the termination of the valve coil at terminal USE on the HC-DVR board.</li> <li>2. Check terminal US for 120VAC with respect to 1 bus.</li> </ol>



**Table 6.1 Status and Error Messages**

Scrolling Message - Special Event Message
<b>NORMAL OPERATION</b>
<b>Description:</b> The elevator is on “automatic” or Normal passenger operation.
<b>NORMAL (PIT FLOOD) OPERATION</b>
<b>Description:</b> The elevator is on “automatic” or Normal passenger operation with the pit flood input active. In this mode, the car will not serve floors beneath the flood level set. <a href="#">Please refer to “FLR COUNT BELOW FLOOD LEVEL?” on page 5-52.</a>
<b>Troubleshooting:</b> If pit flood operation is in error, refer to the drawings for the job and verify the PTFLD input is correctly configured (connected/disconnected/connected in error).
<b>OLM INPUT FAILURE</b>
<b>Description:</b> The OLM input monitors the status of the both the thermal overload and the starter overload contacts. Bus 2L should be 120VAC and relay SAFL should be picked only if the doors are locked. 2MV bus must also be active.
<b>Troubleshooting:</b> 1. Check that IDC terminal 2L on the HC-CTL board connects to IDC terminal 2L on the HC-DVR board. 2. Check the wiring of the thermal overload between terminals TO1 and TO2 on the HC-DVR board. 3. Check the wiring of the starter overload between terminal OL1 and OL2 (if present).
<b>OLM INPUT IS LOW</b>
<b>Description:</b> The OLM input monitors the status of the both the thermal overload and the starter overload contacts. Bus 2L should be 120VAC and relay SAFL should be picked only if the doors are locked. 2MV bus must also be active.
<b>Troubleshooting:</b> 1. Check the wiring of the thermal overload between terminals TO1 and TO2 on the HC-DVR board. 2. Check the wiring of the starter overload between terminal OL1 and OL2 (if present).
<b>OVERLOAD CONDITION</b>
<b>Description:</b> The car appears to be overloaded, as indicated by the load weigher input OVL.
<b>Troubleshooting:</b> Check the OVL input. If power is present on the OVL input, the load weigher contact associated with this input is closed. This contact being closed indicates to the elevator computer that the car is overloaded.
<b>PASSCODE REQUEST</b>
<b>Description:</b> The Passcode Request Option has been activated from the System Mode Menu.
<b>Troubleshooting:</b> The system can be run on Inspection operation only. The pass code must be entered correctly in the System Mode Menu in order to deactivate this option and allow the controller to run normally. <a href="#">Please refer to “Passcode Request Menu” on page 5-61.</a>
<b>POWER TRANSFER INPUT ACTIVE</b>
<b>Description:</b> The PTI input has been activated.
<b>Troubleshooting:</b> Go into Program Mode and see if any of the inputs are programmed as PTI. Then, check to see if that particular input is activated.
<b>PRESSURE SWITCH ACTIVATED</b>
<b>Description:</b> This message is displayed when the Pressure Switch Input (PSS) is programmed and activated (low).
<b>Troubleshooting:</b> Check the associated hardware device and take appropriate action.
<b>R2L INPUT FAILURE (CTLA)</b>
<b>Description:</b> The R2L input monitors the state of the 2L relay. The R2L input must be low when the 2L bus is active and high when the 2L bus is low.
<b>Troubleshooting:</b> Check the circuitry associated with the 2L relay.

**Table 6.1 Status and Error Messages**

Scrolling Message - Special Event Message
<p><b>RDR SPA IS OFFLINE (CTLB)</b></p> <p><b>Description:</b> Safety processor A on the HC-RDR board is offline.</p> <p><b>Troubleshooting:</b></p> <ol style="list-style-type: none"> <li>1. Power to the HC-RDR board may not be connected. Check the CAN bus connection between the HC-RDR board and the HC-CHP CAN hub and board.</li> <li>2. Make sure that jumper JP3 on the HC-RDR board is not shorted.</li> <li>3. If the SPA indicator is not lit, reboot the processor by cycling the power to the controller or by removing CAN bus connection to the HC-RDR board for a few seconds.</li> </ol>
<p><b>RDR SPB IS OFFLINE (CTLB)</b></p> <p><b>Description:</b> Safety processor B on the HC-RDR board is offline.</p> <p><b>Troubleshooting:</b></p> <ol style="list-style-type: none"> <li>1. Power to the HC-RDR board may not be connected. Check the CAN bus connection between the HC-RDR board and the HC-CHP CAN hub and board.</li> <li>2. Make sure that jumper JP4 on the HC-RDR board is not shorted.</li> <li>3. If the SPB indicator is not lit, reboot the processor by cycling the power to the controller or by removing CAN bus connection to the HC-RDR board for a few seconds.</li> </ol>
<p><b>REAR CAR DOOR BYPASS SW. FAILURE (RDRA) (Hydro only)</b></p> <p><b>Description:</b> Indicates that the REAR CAR DOOR BYPASS switch has failed.</p> <p><b>Troubleshooting:</b></p> <ol style="list-style-type: none"> <li>1. Cycle the HC-RDR board car door bypass switch a few times to exercise it. Verify that it is fully in the ON or OFF position.</li> <li>2. Verify 2S and GSR connections and wiring.</li> </ol>
<p><b>REAR DOL &amp; DLK ARE BOTH ACTIVE</b></p> <p><b>Description:</b> The Door Open Limit Rear and the Door Lock inputs are both active, DOLR=0 and DLK=1. A problem with DOLR and/or DLK circuitry or wiring.</p> <p><b>Troubleshooting:</b> Inspect the Door Open Limit Rear and the Door Lock circuitry and wiring. When this error is generated, the car will shutdown with the doors open and will not answer any calls. To reset this error condition, put the car on Inspection operation.</p>
<p><b>REAR DOOR FAILED TO CLOSE</b></p> <p><b>Description:</b> Doors Open (DCLR = 1). There is a problem with DCLR circuitry or wiring.</p> <p><b>Troubleshooting:</b> Inspect the Door Closed Limit Rear circuitry and wiring. When this error is generated, the car is not allowed to run.</p>
<p><b>REAR DOOR IS LOCKED BUT NOT FULLY CLOSED</b></p> <p><b>Description:</b> Rear Doors Open (DCLR = 1) and Locked (DLK = 1). Indicates a problem with DCLR and/or DLK circuitry or wiring.</p> <p><b>Troubleshooting:</b> Inspect the Door Closed Limit Rear and the Door Lock circuitry and wiring. When this error is generated, the car is not allowed to run.</p>
<p><b>REAR DOOR LOCK SWITCH FAILURE (NYCHA)</b></p> <p><b>Description:</b> The rear door lock contacts have failed closed.</p> <p><b>Troubleshooting:</b> Ensure that with the rear hoistway doors closed and locked, there is power on the DLSR input and no power present on the DCLR input.</p>
<p><b>REAR DOOR OPEN LIMIT FAILURE</b></p> <p><b>Description:</b> The rear door open limit switch has failed open.</p> <p><b>Troubleshooting:</b> Ensure that the rear car gate is open, there is no power on the DOLR input and no power is present on the DLSR or CDR inputs.</p>
<p><b>REAR GATE SWITCH FAILURE (NYCHA)</b></p> <p><b>Description:</b> The rear car gate switch has failed closed.</p> <p><b>Troubleshooting:</b> Ensure that with the rear car gate closed, there is power on the GSR input and no power present on the DCLR input.</p>

Table 6.1 Status and Error Messages

Scrolling Message - Special Event Message
<b>REAR HOISTWAY DOOR BYPASS SW. FAILURE (RDRA)</b>
<p><b>Description:</b> Indicates that the REAR HOISTWAY DOOR BYPASS switch has failed.</p> <p><b>Troubleshooting:</b></p> <ol style="list-style-type: none"> <li>1. Cycle the HC-RDR board hoistway door bypass switch a few times to exercise it. Verify that it is fully in the ON or OFF position.</li> <li>2. Verify 2S and DLABR connections and wiring.</li> </ol>
<b>REDUNDANCY DOOR LOCK RELAY FAILURE</b>
<p><b>Description:</b> The one or both of the front or rear door lock relays has failed closed.</p> <p><b>Troubleshooting:</b> Ensure that with the hoistway doors open, there is no power present on the RDLS or RDLSR inputs. If power is present, one or more of the door lock relays has failed in the closed or picked position.</p>
<b>REDUNDANCY FRONT GATE SWITCH FAILURE (Non ASME-2000)</b>
<p><b>Description:</b> The car gate switch relay has failed closed.</p> <p><b>Troubleshooting:</b> Ensure that with the car gate open, there is no power present on the RGS input. If power is present, the car gate switch relay has failed closed.</p>
<b>REDUNDANCY REAR GATE SWITCH FAILURE</b>
<p><b>Description:</b> The rear car gate switch relay has failed closed.</p> <p><b>Troubleshooting:</b> Ensure that with the rear car gate open, there is no power on the RGSR input. If power is present, the rear car gate switch relay has failed closed.</p>
<b>RESTORING SAFETY (CTLA)</b>
<p><b>Description:</b> This message will be displayed while the system checks the safety integrity of the controller when coming out of car top inspection.</p>
<b>RFV INPUT FAILED TO ACTIVATE (CTLA) (Hydro only)</b>
<p><b>Description:</b> With the VALVE TYPE parameter set to PILOT RELAYS, the Redundancy Fast Valves (RFV) input did not go high when controller deactivated the associated pilot relays.</p> <p><b>Troubleshooting:</b></p> <ol style="list-style-type: none"> <li>1. Check the wiring to the RFV spare input.</li> <li>2. Verify that the RFV input is programmed in the correct spare input location.</li> <li>3. <a href="#">Please refer to "Troubleshooting Using External Memory Mode" on page 5-56.</a> Set the proper external memory address for the RFV spare input. Use a 120VAC jumper to toggle the RSV input and verify that the appropriate bit toggles.</li> <li>4. Verify that the appropriate fast pilot relay (up or down) picks at the beginning of a high speed run and drops at the slow down point for the floor.</li> </ol>
<b>RFV INPUT FAILED TO DEACTIVATE (CTLC) (Hydro only)</b>
<p><b>Description:</b> With the VALVE TYPE parameter set to PILOT RELAYS, the Redundancy Fast Valves (RFV) input did not go low when controller activated the associated pilot relays.</p> <p><b>Troubleshooting:</b></p> <ol style="list-style-type: none"> <li>1. Check the wiring to the RFV spare input.</li> <li>2. Verify that the RFV input is programmed in the correct spare input location.</li> <li>3. <a href="#">Please refer to "Troubleshooting Using External Memory Mode" on page 5-56.</a> Set the proper external memory address for the RFV spare input. Use a 120VAC jumper to toggle the RSV input and verify that the appropriate bit toggles.</li> <li>4. Verify that the appropriate fast pilot relay (up or down) picks at the beginning of a high speed run and drops at the slow down point for the floor.</li> </ol>

**Table 6.1 Status and Error Messages**

Scrolling Message - Special Event Message
<p><b>RP SENSOR TRIPPED</b> <i>(Hydro only)</i></p> <p><b>Description:</b> The Reverse Phase sensor detected a problem with the incoming power and the RP sensor's N/C contacts activated HC-DVR board RP1 input (active high - 120VAC). The car returns to the bottom landing, cycles the doors and shuts down. The DOB can cycle the doors.</p> <p><b>Troubleshooting:</b></p> <ol style="list-style-type: none"> <li>1. Verify that HC-DVR board terminal RP1 to ground = 120VAC.</li> <li>2. Check the wiring (phase rotation) to the motor starter.</li> <li>3. Check the wiring to the RP sensor (incorrect, loose or missing wires).</li> </ol>
<p><b>RSV INPUT FAILED TO ACTIVATE</b> (CTLA) (Hydro only)</p> <p><b>Description:</b> With the VALVE TYPE parameter set to PILOT RELAYS, the Redundancy Slow Valves (RSV) input did not go high when controller deactivated the associated pilot relays.</p> <p><b>Troubleshooting:</b></p> <ol style="list-style-type: none"> <li>1. Check the wiring to the RSV spare input.</li> <li>2. Verify that the RSV input is programmed in the correct spare input location.</li> <li>3. <a href="#">Please refer to "Troubleshooting Using External Memory Mode" on page 5-56.</a> Set the proper external memory address for the RSV spare input. Use a 120VAC jumper to toggle the RSV input and verify that the appropriate bit toggles.</li> <li>4. Verify that the appropriate slow pilot relay (up or down) remains picked throughout the run.</li> </ol>
<p><b>RSV INPUT FAILED TO DEACTIVATE</b> (CTLC) (Hydro only)</p> <p><b>Description:</b> With the VALVE TYPE parameter set to PILOT RELAYS, the Redundancy Slow Valves (RSV) input did not go low when controller activated the associated pilot relays.</p> <p><b>Troubleshooting:</b></p> <ol style="list-style-type: none"> <li>1. Check the wiring to the RSV spare input.</li> <li>2. Verify that the RSV input is programmed in the correct spare input location.</li> <li>3. <a href="#">Please refer to "Troubleshooting Using External Memory Mode" on page 5-56.</a> Set the proper external memory address for the RSV spare input. Use a 120VAC jumper to toggle the RSV input and verify that the appropriate bit toggles.</li> <li>4. Verify that the appropriate slow pilot relay (up or down) remains picked throughout the run.</li> </ol>
<p><b>SABBATH OPERATION ACTIVE</b></p> <p><b>Description:</b> The spare input SAB has been activated.</p> <p><b>Troubleshooting:</b> Check spare input bit address for SAB. Verify that the spare input address matches the SAB flag. Check voltage level at the SAB input.</p>
<p><b>SAFC INPUT FAILURE</b> (CTLA)</p> <p><b>Description:</b> The microcontroller has detected that the Car Safety String (SAFC) input on the HC-CTL board is in an incorrect state. It should not have 120VAC unless the SAFH input also has 120VAC.</p> <p><b>Troubleshooting:</b> Check the wiring or devices connected to the SAFC input. This could also be caused by a component failure on the HC-CTL board.</p>
<p><b>SAFETY CIRCUIT IS OPEN</b></p> <p><b>Description:</b> The Car Operating Panel emergency stop switch has been pulled, or another contact switch in the safety circuit is in the open position.</p> <p><b>Troubleshooting:</b> Check the C.O.P. stop switch. Check the other switches and contacts in the safety string. Check safety string wiring against the MCE wiring diagrams.</p>
<p><b>SAFETY DROPPED BY SPB</b> (CTLB)</p> <p><b>Description:</b> Safety processor B on the HC-CTL board has dropped the safety relay.</p> <p><b>Troubleshooting:</b></p> <ol style="list-style-type: none"> <li>1. Cycle power.</li> <li>2. Check the event log to see what events led up to the occurrence.</li> </ol>

Table 6.1 Status and Error Messages

Scrolling Message - Special Event Message
<p><b>SPA IS OFFLINE (CTLB)</b></p> <p><b>Description:</b> Safety processor A on the HC-CTL board is offline.</p> <p><b>Troubleshooting:</b></p> <ol style="list-style-type: none"> <li>1. Power to the HC-CTL board may not be connected. Check the CAN bus connection between the HC-CTL board and the HC-CHP CAN hub and board.</li> <li>2. Make sure that jumper JP3 on the HC-CTL board is not shorted.</li> <li>3. If the SPA indicator is not lit, reboot the processor by cycling the power to the controller or by removing CAN bus connection to the HC-CTL board for a few seconds.</li> <li>4. If fault occurs while updating software, refer to update instructions and repeat process.</li> </ol>
<p><b>SPB IS OFFLINE (CTLA)</b></p> <p><b>Description:</b> Safety processor B on the HC-CTL board is offline.</p> <p><b>Troubleshooting:</b></p> <ol style="list-style-type: none"> <li>1. Power to the HC-CTL board may not be connected. Check the CAN bus connection between the HC-CTL board and the HC-CHP CAN hub and board.</li> <li>2. Make sure that jumper JP4 on the HC-CTL board is not shorted.</li> <li>3. If the SPB indicator is not lit, reboot the processor by cycling the power to the controller or by removing CAN bus connection to the HC-CTL board for a few seconds.</li> <li>4. If fault occurs while updating software, refer to update instructions and repeat process.</li> </ol>
<p><b>SPC IS OFFLINE (CTLA)</b></p> <p><b>Description:</b> Safety processor C on the HC-CTL board is offline.</p> <p><b>Troubleshooting:</b></p> <ol style="list-style-type: none"> <li>1. Power to the HC-CTL board may not be connected. Check the CAN bus connection between the HC-CTL board and the HC-CHP CAN hub and board.</li> <li>2. Make sure that jumper JP6 on the HC-CTL board is not shorted.</li> <li>3. If the SPC indicator is not lit, reboot the processor by cycling the power to the controller or by removing CAN bus connection to the HC-CTL board for a few seconds.</li> <li>4. If fault occurs while updating software, refer to update instructions and repeat process.</li> </ol>
<p><b>STARTER FAULT CONTACT OPEN (Hydro only)</b></p> <p><b>Description:</b> The solid-state starter internal fault contact is open.</p> <p><b>Troubleshooting:</b></p> <ol style="list-style-type: none"> <li>1. Check the solid-state starter fault display screen and refer to the starter manual for troubleshooting instructions.</li> <li>2. Verify that terminal YR1 has 120VAC.</li> </ol>
<p><b>STARTER TYPE ERROR (Hydro only)</b></p> <p><b>Description:</b> The HC-DVR board has received an invalid starter type from the from the MPU board.</p> <p><b>Troubleshooting:</b> May be caused by a communication error between the HC-MPU and HC-DVR boards, call MCE Tech Support.</p>
<p><b>SYNCHRONIZATION OPERATION (Hydro only)</b></p> <p><b>Description:</b> The SYNCI input has been activated</p> <p><b>Troubleshooting:</b> Ensure that the synchronization function is required. This function is used on PHC controllers used on jobs with two jacks or telescopic jacks. If the SYNCI Input option is programmed and has been activated, the SYNC function will be performed as soon as all demand is serviced. Ensure that the circuit connected to SYNCI input is not activating the input inappropriately.</p>
<p><b>TIME OUT OF SERVICE</b></p> <p><b>Description:</b> The T.O.S. timer has expired.</p> <p><b>Troubleshooting:</b> The elevator has been delayed, usually by a door being obstructed. The Time Out of Service timer has expired and the elevator has been taken out of service. <a href="#">Please refer to "TIME OUT OF SERVICE TIMER (Range: 15-240 Seconds, or None)" on page 5-26.</a></p>

**Table 6.1 Status and Error Messages**

<b>Scrolling Message - Special Event Message</b>
<b>TOP ACCESS SW. FAILURE (CTLB)</b>
<p><b>Description:</b> The Up and Down Top Access inputs are active at the same time.  <b>Troubleshooting:</b> Check the wiring and switches associated with the ATU and ATD inputs.</p>
<b>UP AND DOWN TERMINAL SPEED REDUCING LIMITS OPEN</b>
<p><b>Description:</b> Usually indicates a problem with the up slow down or the down slow down switch.  <b>Troubleshooting:</b> Inspect both switches and associated wiring. The down slow down switch should be closed, unless the car is at the bottom; then it should be open. The up slow down switch should be closed, unless the car is at the top; then it should be open.</p>
<b>UP NORMAL LIMIT OPEN</b>
<p><b>Description:</b> This message indicates that the car has traveled beyond the top terminal landing and has opened the up normal (directional) terminal switch.  <b>Troubleshooting:</b></p> <ol style="list-style-type: none"> <li>1. Check the location of the car.</li> <li>2. Check the voltage at terminal UNTD.</li> <li>3. Check the limit switch connections.</li> </ol>
<b>UP TERMINAL LIMIT FAILURE</b>
<p><b>Description:</b> Both the Up Slow Limit and Up Emergency Limit switches have been detected to be in opposite states. These switches should open/close simultaneously, meaning that the voltage at these terminals should always be identical.  <b>Troubleshooting:</b></p> <ol style="list-style-type: none"> <li>1. Check the connections to terminals USL1 and USL2.</li> <li>2. Check the limit switches for proper operation.</li> </ol>
<b>VALVE LIMIT TIMER (ANTI-STALL) ELAPSED (Hydro only)</b>
<p><b>Description:</b> Indicates a problem with the valve or valve solenoids.  <b>Troubleshooting:</b> Inspect the valves &amp; valve solenoids and associated wiring.</p>
<b>VISCOSITY CONTROL FUNCTION (Hydro only)</b>
<p><b>Description:</b> The Viscosity Control Input (VCI) is <i>ON</i>. The computer is periodically running the motor to warm the oil in the system.  <b>Troubleshooting:</b> Check the device that is wired to the input (usually an oil temperature sensor).</p>
<b>YRD INPUT FAILURE</b>
<p><b>Description:</b> The Y Contactor Redundancy (YRD) input monitors the normally closed auxiliary contact of the Y starter contactor.  <b>Troubleshooting:</b></p> <ol style="list-style-type: none"> <li>1. The wiring or devices connected to YR1 input may not be terminated.</li> <li>2. Check the Y auxiliary contact wired to terminal YR1 and replace if necessary.</li> <li>3. Check the operation of the Y contactor.</li> </ol>
6-17-11

## PC Board Quick References

This section contains information about Motion 2000 circuit boards including photographs with informational call outs, input/outputs, indicators, jumpers, test points and other information pertinent to troubleshooting.

The circuit boards are listed in the table below. If you are viewing this file on a computer, click the page number to jump to the appropriate section.

**Table 6.2 Motion 2000 Circuit Boards**

Board	Name	See
HC- <b>CHP</b>	CAN Hub and Power Supply Board	<a href="#">page 6-36</a>
HC- <b>CTL</b>	Control Board	<a href="#">page 6-38</a>
HC- <b>DVR</b>	Driver Board	<a href="#">page 6-48</a>
HC- <b>MPU</b>	Main Processor Unit Board	<a href="#">page 6-51</a>
HC- <b>RDR</b>	Rear Door Board	<a href="#">page 6-54</a>
HC- <b>UIO</b>	Universal Input/Output Board	<a href="#">page 6-58</a>
MC- <b>CPI</b>	Car Panel Interface Board	<a href="#">page 6-62</a>
MC- <b>LSI</b>	Landing System Interface Board	<a href="#">page 6-65</a>
SC- <b>3HN</b>	Serial Hall Call Node Board	<a href="#">page 6-68</a>



## HC-CHP CAN Hub and Power Supply Board

This board provides 5-volt, 4-amp DC power for digital integrated circuits throughout the controller. It also provides a central connection point for the Controller Area Network (CAN).i

Figure 6.1 HC-CHP CAN Hub and Power Supply Board

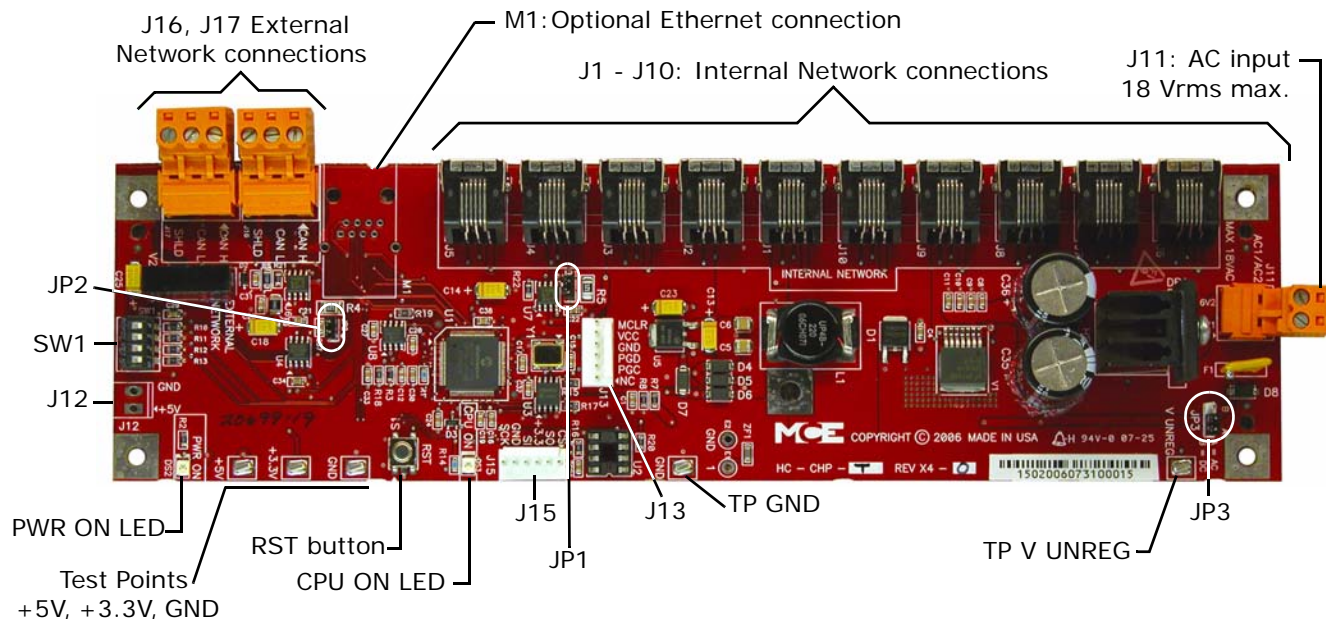

### Connectors

- J1 - J10: Internal network connections - to boards inside the controller cabinet.
- J11: Low voltage AC input - 16V1/16V2, maximum 18Vrms.
- J12: optional +5Vdc output.
- J13: In-circuit serial programming port for microcontroller.
- J15: Connector used to interface with external serial flash memory.
- J16, J17: External network connections - to boards or equipment outside the controller cabinet.
- M1: Optional Ethernet connection.

### Jumpers

- JP1: Internal CAN bus termination resistor - always closed.
- JP2: External CAN bus termination resistor - always closed.
- JP3: AC or DC voltage monitor. Always set to position A to monitor the loss of AC voltage.

### Test Points

- +5V: +5Vdc measured between this test point and TP GND.
- +3.5V: +3.3Vdc measured between this test point and TP GND.
- GND: 0V.
- V UNREG: 24V  $\pm$  20% measured between this test point and TP GND.



**Indicators**

- PWR ON: +5V indicator.
- CPU ON: LED on indicates that the on-board microcontroller is functional.

**Switches**

- SW1: DIP switches (see SW1 DIP Switch Settings below).
- RST: microcontroller reset button.

**Figure 6.2 Upgrading Motion 2000 Firmware**

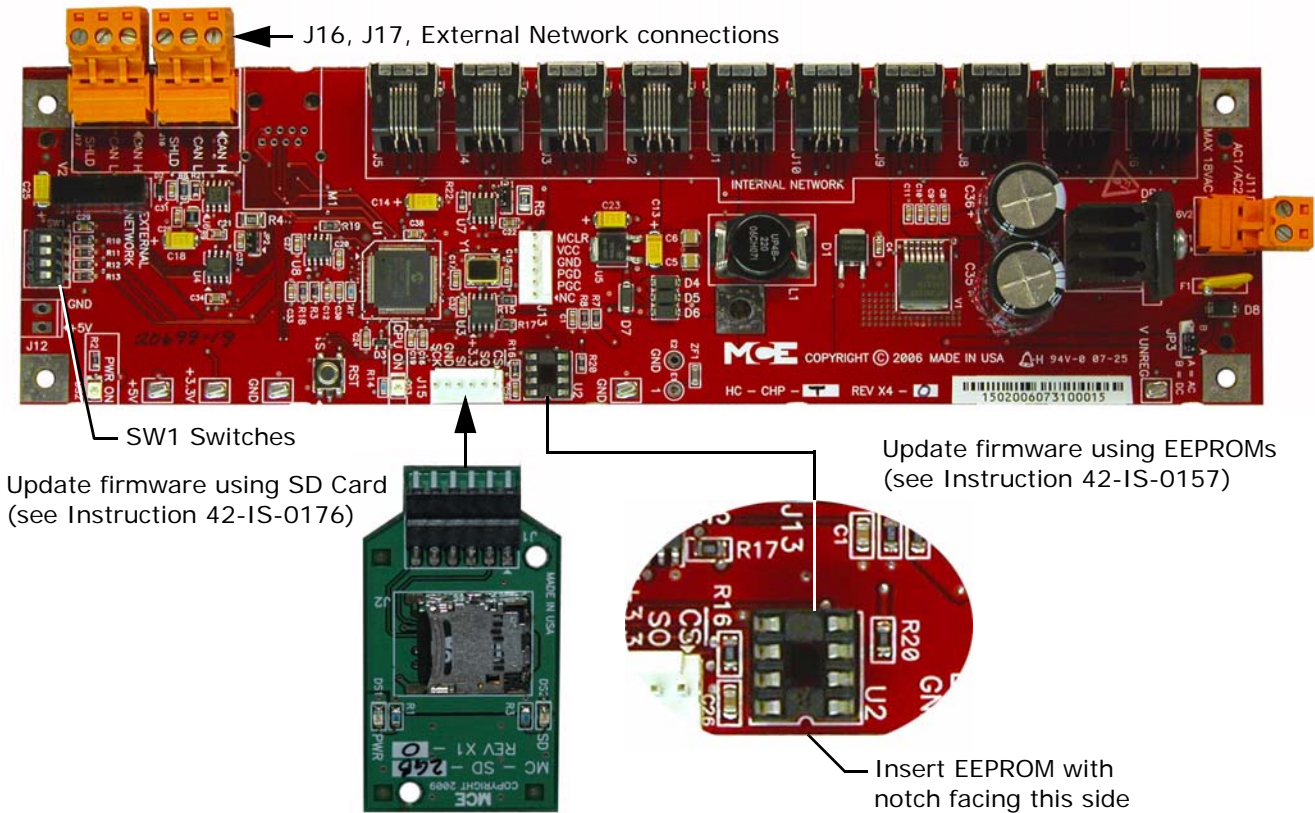

**SW1 DIP Switch Settings**



SW1 DIP Switch Settings			
DIP 1	DIP 2	DIP 3	Description
Off	Off	Off	Normal boot up (bypasses firmware update)
On	On	On	Updates firmware different from EEPROM or SD card
On	On	Off	Forced update (fixes corrupted software)

On = switch left, Off = switch right

**DIP 4** Sets the communication baud rate for the External CAN bus (Off = 125 kbs, On = 250 kbs).  
DO NOT change this switch setting.

## HC-CTL Control Board

The HC-CTL Control board monitors I/O, performs safety functions and front door operation. The HC-CTL board is responsible for Inspection, Fire Service, Landing System, door lock bypass and lanterns and gongs.

Figure 6.3 HC-CTL Control Board

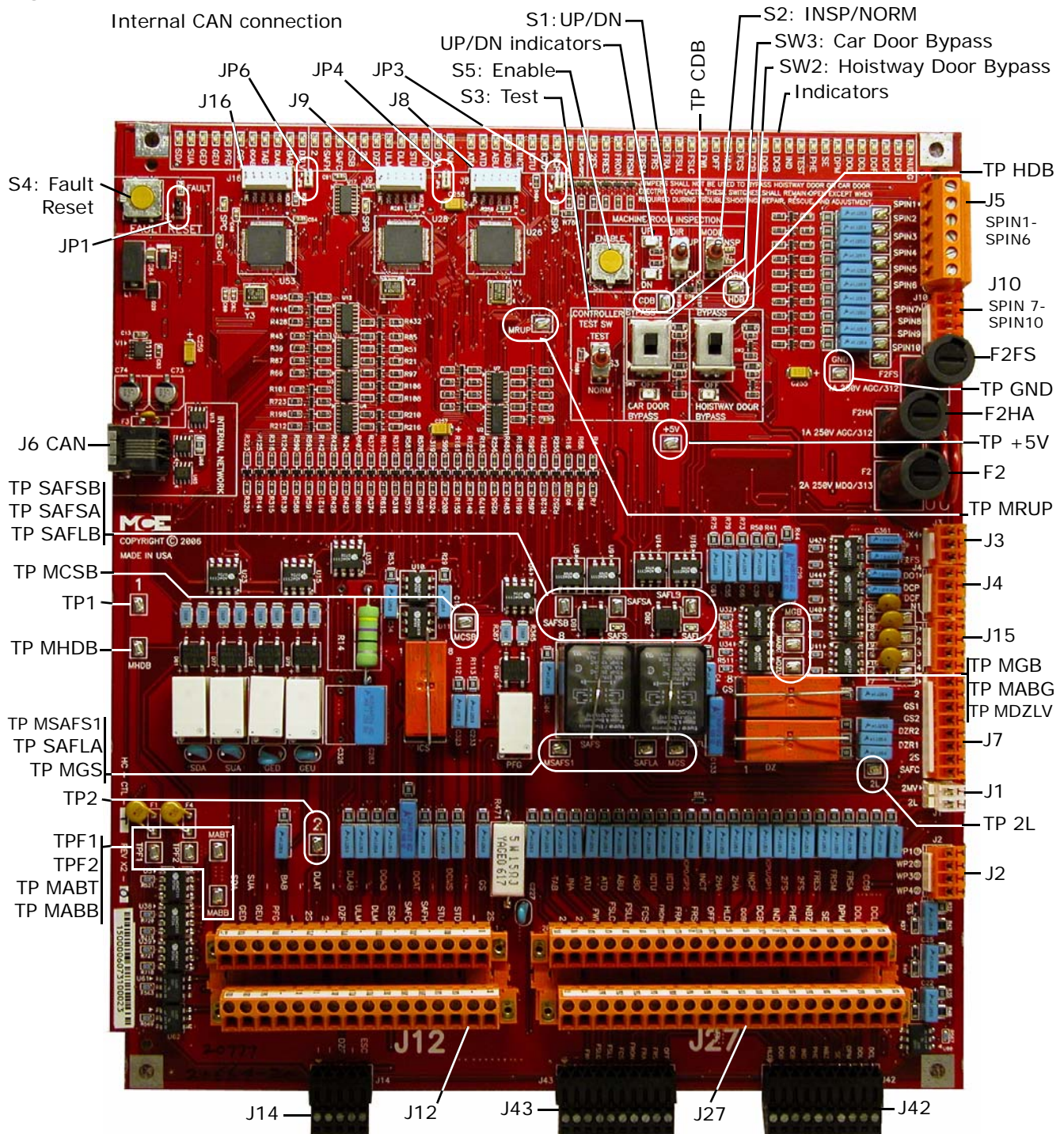

**Table 6.3 HC-CTL Board Terminals**

Connector	Terminal	Description
J1	2MV	Provides 120VAC to 2L bus when SAFL and SAFS relays are picked (Input).
	2L	Provides 120VAC to valves and motor signals when doors are locked and safety string is made up (Output).
J2	WP1	not currently used
	WP2	not currently used
	WP3	not currently used
	WP4	not currently used
J3	X4	120VAC from power transformer (input)
	1	1 bus (ground)
	F2FS	Provides 120VAC to fire service features sensors and signals
J4	DO1	Door open function (Output that signals the controller to attempt to open the doors)
	DCP	Door close power
	DCF	Door close function (Output that signals the controller to attempt to close the doors)
	N1	Nudging (Output that signals the controller to attempt to close the doors with reduced torque)
J5	SPIN1	Programmable spare input #1
	SPIN2	Programmable spare input #2
	SPIN3	Programmable spare input #3
	SPIN4	Programmable spare input #4
	SPIN5	Programmable spare input #5
	SPIN6	Programmable spare input #6
J6		Internal CAN connection
J7	1	1 bus (Ground)
	2	2 bus (120 VAC)
	GS1	Rear door lock string input (Controllers without rear doors should have a jumper between GS1 and GS2) (used for board interconnections)
	GS2	Rear door lock string output (used for board interconnections)
	DZR2	Rear Door zone (Output) (used for board interconnections)
	DZR1	Rear Door zone (Input) (used for board interconnections)
	2S	Provides 120VAC to the gate switch, inspection access switch, and door locks
	SAFC	When this signal is low, in-car stop is activated. ESC terminal provides 120VAC to this signal during fire recall (In car stop switch bypass)
J8		Used to program the U26 microcontroller
J9		Used to program the U28 microcontroller

**Table 6.3 HC-CTL Board Terminals**

Connector	Terminal	Description
J10	SPIN7	Programmable spare input #7
	SPIN8	Programmable spare input #8
	SPIN9	Programmable spare input #9
	SPIN10	Programmable spare input #10
J12 (1-16) upper connector	GS	Gate Switch (input)
	-	No connection
	DCMS	Door Contact Middle String (input)
	-	No connection
	DCAT	Door Contact Access Top (input)
	-	No connection
	DCAB	Door Contact Access Bottom (input)
	-	No connection
	DLAB	Bottom Door Lock (input)
	-	No connection
	DLAT	Top Door Lock (input)
	-	No connection
	BAB	Bottom Access 2nd Pole
	-	No connection
	SUA	Up Direction Arrow (output)
SDA	Down Direction Arrow (output)	

**Table 6.3 HC-CTL Board Terminals**

Connector	Terminal	Description
J12 (17-32) lower connector	2S	Provides 120VAC to the gate switch, inspection access switch, and door locks (output)
	-	No connection
	STD	Step Down (input)
	STU	Step Up (input)
	SAFH	Hoistway Safety String (input)
	SAFC	Car Safety String (input)
	ESC	Hoistway Safety (input)
	DLM	Level Down (input)
	ULM	Level Up (input)
	DZF	Front Door Zone (input)
	2	2 Bus
	2S	2S safety bus
	-	No connection
	PFG	Passing Floor Gong (output)
	GEU	Gong Enable Up (output)
	GED	Gong Enable Down (output)
J14	ESC	Hoistway Safety (input)
	-	No connection
	DZF	Front Door Zone (input)
	-	No connection
	-	No connection
J15	1	Spare Out 1 ( <b>Do not connect to 1 Bus</b> )
	2	Spare Out 2 ( <b>Do not connect to 2 Bus</b> )
	3	Spare Out 3
	4	Spare Out 4
J16		Used to program the U53 microcontroller

**Table 6.3 HC-CTL Board Terminals**

Connector	Terminal	Description
J27 (1-20) upper connector	CCB	(FCCC) Fire Phase II Car Call Cancel button (input)
	FRSA	Fire Service Alternate Initiating Device, machine room (input)
	FRSM	Fire Service Main Initiating Device, all other hoistway fire service initiating devices (input)
	FRES	Fire Service Reset (input)
	2FS	Fire Service Bus
	2FS	Fire Service Bus
	ICPU/GP1	In-Car Panel Inspection Up Direction/General Purpose (Input)
	INCP	In-Car Panel Inspection (Input)
	2HA	Hoistway Access Power (Input)
	2HA	Hoistway Access Power (Input)
	INCT	Car Top Inspection
	ICPD/GP2	In-Car Panel Inspection Down Direction/General Purpose (Input)
	ICTD	Car Top Inspection Down Direction (Input)
	ICTU	Car Top Inspection Up Direction (Input)
	ABD	Bottom Hoistway Access Down Direction (Input)
	ABU	Bottom Hoistway Access Up Direction (Input)
	ATD	Top Hoistway Access Down Direction (Input)
	ATU	Top Hoistway Access Up Direction (Input)
	INA	Hoistway Access Inspection Up Direction (Input)
	TAB	Top Access 2nd Pole (Input)

**Table 6.3 HC-CTL Board Terminals**

Connector	Terminal	Description
J27 21-40 lower connector	DCL	Door Close Limit (Input)
	DOL	Door Open Limit (Input)
	DPM	Door Position Monitor (Input)
	SE	Safety Edge (input)
	NBZ	Nudging Buzzer (output)
	PHE	Photo Eye (input)
	IND	Independent Service (input)
	DCB	Door Close Button (input)
	DOB	Door Open Button (input)
	HLD	Phase II Fire Service Operation Hold (Hold position of 3-position fire service operation switch, output)
	OFF	Phase II Fire Service Operation Off (Default position of 3-position fire service operation switch, output)
	FRS	Smoke/Fire Sensors for all landing not that are not main (input)
	FRA	Main Landing Smoke Sensor (input)
	FRON	Fire Recall Operation (input)
	FCS	Phase II Fire Service Operation On (On position of 3-position fire service operation switch)
	FSLI	Fire Service Indicator for Lobby (output)
	FSLC	C.O.P. Fire Service Light (output)
	FWI	Fire Service Buzzer (output)
	2	2 Bus
	2	2 Bus
J42	DCL	MCE connections for Door Operation (See J27)
	DOL	MCE connections for Door Operation (See J27)
	DPM	MCE connections for Door Operation (See J27)
	SE	MCE connections for Door Operation (See J27)
	NBZ	MCE connections for Door Operation (See J27)
	PHE	MCE connections for Door Operation (See J27)
	IND	MCE connections for Door Operation (See J27)
	DCB	MCE connections for Door Operation (See J27)
	DOB	MCE connections for Door Operation (See J27)
	HLD	MCE connections for Door Operation (See J27)

**Table 6.3 HC-CTL Board Terminals**

Connector	Terminal	Description
J43	OFF	MCE connections for Fire Service (See J27)
	FRS	MCE connections for Fire Service (See J27)
	FRA	MCE connections for Fire Service (See J27)
	FRON	MCE connections for Fire Service (See J27)
	FCS	MCE connections for Fire Service (See J27)
	FSLL	MCE connections for Fire Service (See J27)
	FSLC	MCE connections for Fire Service (See J27)
	FWI	MCE connections for Fire Service (See J27)
	1	MCE connections for Fire Service (See J27)
	1	MCE connections for Fire Service (See J27)

**Table 6.4 HC-CTL Board Indicators**

Indicator	Description
NUDG	Nudge output on
DCP	Door Close Power input is high
DCF	Door Close Function input is high
DOF	Door Open Function input is high
DCL	Door Close Limit input is high
DOL	Door Open Limit input is high
DPM	Door Position Monitor input is high
SE	Safety Edge input is high
PHE	Photo Eye input is high
TEST	Test Mode switch is in ON position
IND	Independent Service Operation
DCB	Door Close Button
DOB	Door Open Button
CCB	(FCCC) Fire Phase II Car call Cancel button input is active
FCS	Phase II Fire Service Operation On (On position of 3-position fire service operation switch) input is high
HLD	Phase II Fire Service Operation Hold (Hold position of 3-position fire service operation switch) input is high
OFF	Phase II Fire Service Operation Off (Off position of 3-position fire service operation switch) input is high
FWI	Fire Service Buzzer
FSLC	C.O.P. Fire Service Light input is high
FSLL	Fire Service Lobby Light is active



**Table 6.4 HC-CTL Board Indicators**

Indicator	Description
FRA	Fire service alternate initiating device on main landing input is high
FRS	Fire service main initiating device in not on main landing input is high
FRSA	Fire service alternate initiating device machine room input is high
FRSM	Fire service alternate initiating device in hoistway input is high
FRON	Fire Recall Operation input is high
FRES	Fire Service Reset input is high
2FS	2FS bus is high
ICPD/GP2	In-Car Panel Inspection Up Direction input is high
ICPU/GP1	In-Car Panel Inspection input is high
INCP	In-Car Panel Inspection Down Direction input is high
ICTD	Inspection Down Direction input is high
ICTU	Inspection Up Direction input is high
INC	Bottom Hoistway Access Down Direction input is high
ABD	Bottom Hoistway Access Up Direction input is high
ABU	Top Hoistway Access Down Direction input is high
ATD	Top Hoistway Access Up Direction input is high
ATU	Hoistway Access Inspection Up Direction input is high
INA	Inspection Access input is high
2HA	2HA Bus is high
STD	Step Down input is high
STU	Step Up input is high
DLM	Level Down input is high
ULM	Level Up input is high
DZF	Front Door Zone input is high
2S	2S bus
CSB	Car Stop Bypass activated
SAFC	Car Safety String input is high
SAFH	Hoistway safety string input is high
2	2 Bus is high
DZLV	Car is leveled in door zone
BAB	Bottom Access Pole #2 is high
DLAB	Bottom Door Lock is high
TAB	Top Access Pole #2 is high
DCAB	Bottom access door contact input is active
GS	Gate switch is high

**Table 6.4 HC-CTL Board Indicators**

Indicator	Description
PFG	Passing floor gong output is on
GEU	Gong enable up is on
GED	Gong enable down is on
SUA	Directional Arrow Up output is active
SDA	Directional Arrow Down output is active
SPA	Safety Processor A is fully functional
SPB	Safety Processor B is fully functional
SPC	Safety Processor C is fully functional
FAULT	System Fault - A fault is being detected.
UP	Up direction is picked
DN	Down direction is picked
CAR DOOR BYPASS	Car door bypass is active
HOISTWAY DOOR BYPASS	Hoistway door bypass is active
SAFS	SAFS relay is picked
SAFL	SAFL relay is picked

**Table 6.5 HC-CTL Board Jumpers**

Jumper	Description
JP1	Fault Bypass: Open (not yet implemented)
JP3	SPA Hard Reset: Jumper required only to perform 2K testing.
JP4	SPB Hard Reset: Jumper required only to perform 2K testing.
JP6	SPC Hard Reset: Jumper required only to perform 2K testing.

**Table 6.6 HC-CTL Board Fuses**

Fuse	Description
F2S	2S bus fuse
F2HA	F2HA bus fuse
F2	F2 bus fuse

**Table 6.7 HC-CTL Board Test Points**

Test Point	Description
1	1 bus (Ground)
2	2 bus (120VAC)
+5V	+5VDC
CDB	Output of Pole #1 of Car door bypass switch
F1	1 bus with an 80ma re-settable fuse in series
F2	2 bus with an 80ma re-settable fuse in series
GND	Ground (Common)
HDB	Output of Pole #2 of Hoistway door bypass switch
MABB	Access Bypass Bottom monitor signal
MABG	Access Bypass Gate monitor signal
MABT	Access Bypass Top monitor signal
MCSB	In-car Stop Switch Bypass monitor signal
MDZLV	Output from contact of DZLVA relay
MGB	Output of Pole #2 of Car door bypass switch
MGS	Output of #2 NO contact DZ relay
MHDB	Output of Pole #1 of Hoistway door bypass switch
MRUP	Machine Room Up (Not on print)
MSFS1	SAFS Relay monitor signal
SAFLA	Input to SAFL relay coil
SAFLB	Output from SAFL relay coil
SAFSA	Input to SAFS relay coil
SAFSB	Output from SAFS relay coil

**Table 6.8 HC-CTL Board Switches**

Switch	Description
S1	Machine Room Inspection (UP/DN)
S2	Machine Room Inspection (INSP/NORM)
S3	Controller Test (TEST/NORM)
S4	Fault Reset
S5	Machine Room Inspection (ENABLE)
SW2	Hoistway Door Bypass
SW3	Car Door Bypass

## HC-DVR Driver Board

The HC-DVR Driver board(s) control the pump(s) and valves.

Figure 6.4 HC-DVR Driver Board

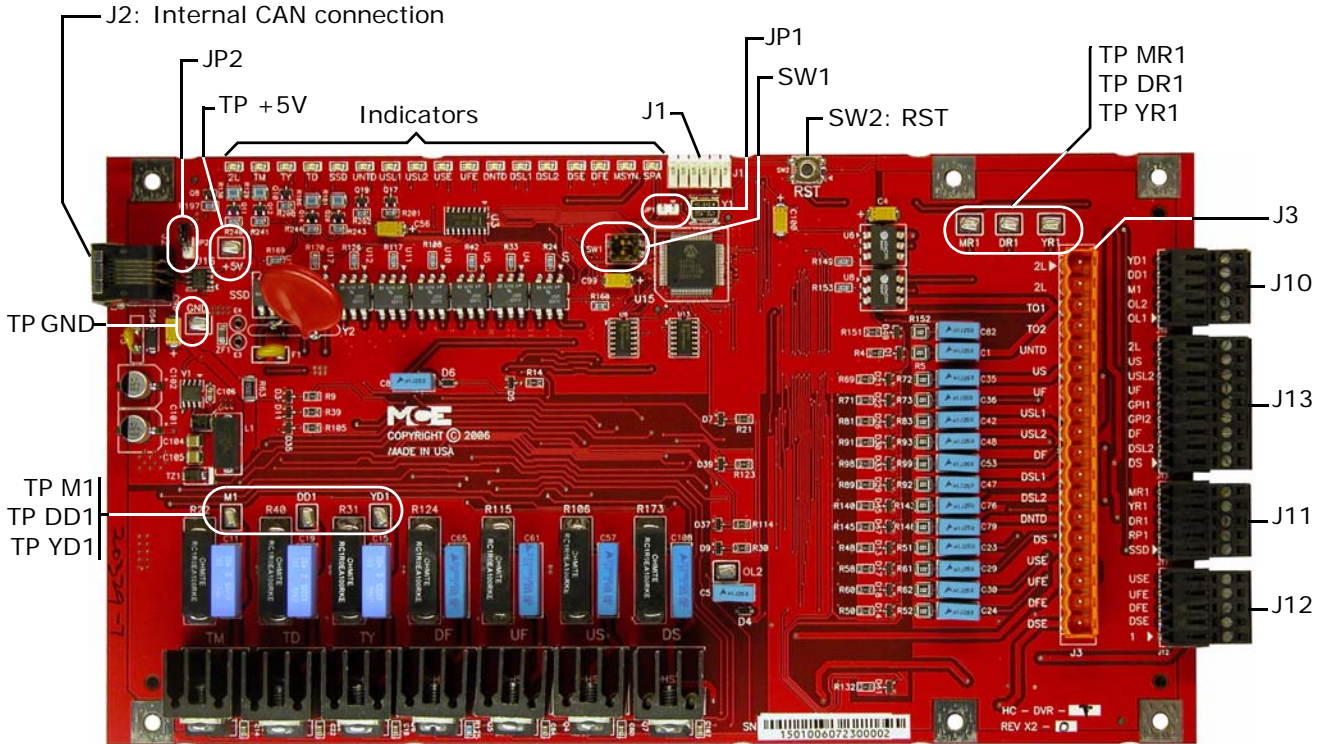

### Switches

- SW1: Board ID. DVR #1: 1 = Off, 2 = Off. DVR #2: 1 = On, 2 = Off. DVR #3: 1 = Off, 2 = On.
- SW2: RST - Processor reset.

### Jumpers

- JP1: Processor hard reset - Open. Jumper required only to perform 2K compliance testing.
- JP2: Internal CAN network termination - Open.

Table 6.9 HC-DVR Board Test Points

Test Point	Description
+5V	+5 Vdc measured between this test point and TP GND.
DD1	TD triac output test point
DR1	Delta contactor monitor input test point
GND	0 volts
M1	TM triac output test point
MR1	Main contactor monitor input test point
YD1	TY triac output test point
YR1	Wye contactor monitor input test point

Table 6.10 HC-DVR Board Terminals

Connector	Terminal	Description
J1		Used to program the U15 microcontroller
J2		Internal CAN signal and power
J3	2L	2L bus output
	2I	2I bus output
	TO1	Connects to input of thermal overload (Also monitors 2L bus)
	TO2	Connects to output of thermal overload
	UNTD	Up normal limit (input)
	US	Up slow (Provides power to valve, output)
	UF	Up fast (Provides power to valve, output)
	USL1	Up slow terminal #1 (input)
	USL2	Up slow terminal #2 (input)
	DF	Down fast (Provides power to valve, output)
	DSL1	Down slow terminal #1 (input)
	DSL2	Down slow terminal #2 (input)
	DNTD	Down normal limit (input)
	DS	Down slow (Provides power to valve)
	USE	Up Slow Enable (Pulls to ground when valve is activated, output)
	UFE	Up Fast Enable (Pulls to ground when valve is activated, output)
	J10	DFE
DSE		Down Slow Enable (Pulls to ground when valve is activated, output)
YD1		Wye contactor coil or solid state start (Pulls to ground when activated, output)
DD1		Delta or A contactor coil (Pulls to ground when activated, output)
M1		Main contactor coil (Pulls to ground when activated, output)
J11	OL2	Connects to overload monitor output
	OL1	Connects to overload monitor input
	MR1	Main contactor monitor input (Connects to 2 bus and normally closed auxiliary contacts)
	YR1	Wye contactor monitor input (Connects to 2 bus and normally closed auxiliary contacts)
	DR1	Delta contactor monitor input (Connects to 2 bus and normally closed auxiliary contacts)
	RP1	Reverse phase sensor input
	SSD	SSD monitor input

**Table 6.10 HC-DVR Board Terminals**

Connector	Terminal	Description
J12	USE	MCE valve connections (See J3)
	UFE	MCE valve connections (See J3)
	DFE	MCE valve connections (See J3)
	DSE	MCE valve connections (See J3)
	1	MCE valve connections (See J3)
J13	2L	MCE limits connections (See J3)
	US	MCE limits connections (See J3)
	USL2	MCE limits connections (See J3)
	UF	MCE limits connections (See J3)
	GPI1	MCE limits connections (See J3)
	GPI2	MCE limits connections (See J3)
	DF	MCE limits connections (See J3)
	DSL2	MCE limits connections (See J3)
	DS	MCE limits connections (See J3)

**Table 6.11 HC-DVR Board Indicators**

Indicator	Description
2L	2L bus is high
TM	TM triac is active
TY	TY triac is active
TD	TD triac is active
SSD	SSD input is active
UNTD	Up normal limit input is high
USL1	Up slow terminal #1 input is high
USL2	Up slow terminal #2 input is high
USE	Up Slow Enable output is active
UFE	Up Fast Enable output is active
DNTD	Down normal limit input is high
DSL1	Down slow terminal #1 input is high
DSL2	Down slow terminal #2 input is high
DSE	Down Slow Enable output is active
DFE	Down Fast Enable output is active
MYSN	Sync Operation Active
SPA	Safety Processor A is running

## HC-MPU Main Processor Board

The HC-MPU board performs control data processing and is responsible for:

- Car operation
- Car communication
- Programming and diagnostics
- Redundancy cycle testing
- System software validation
- Duplexing

**Figure 6.5 HC-MPU Main Processor Unit Board**

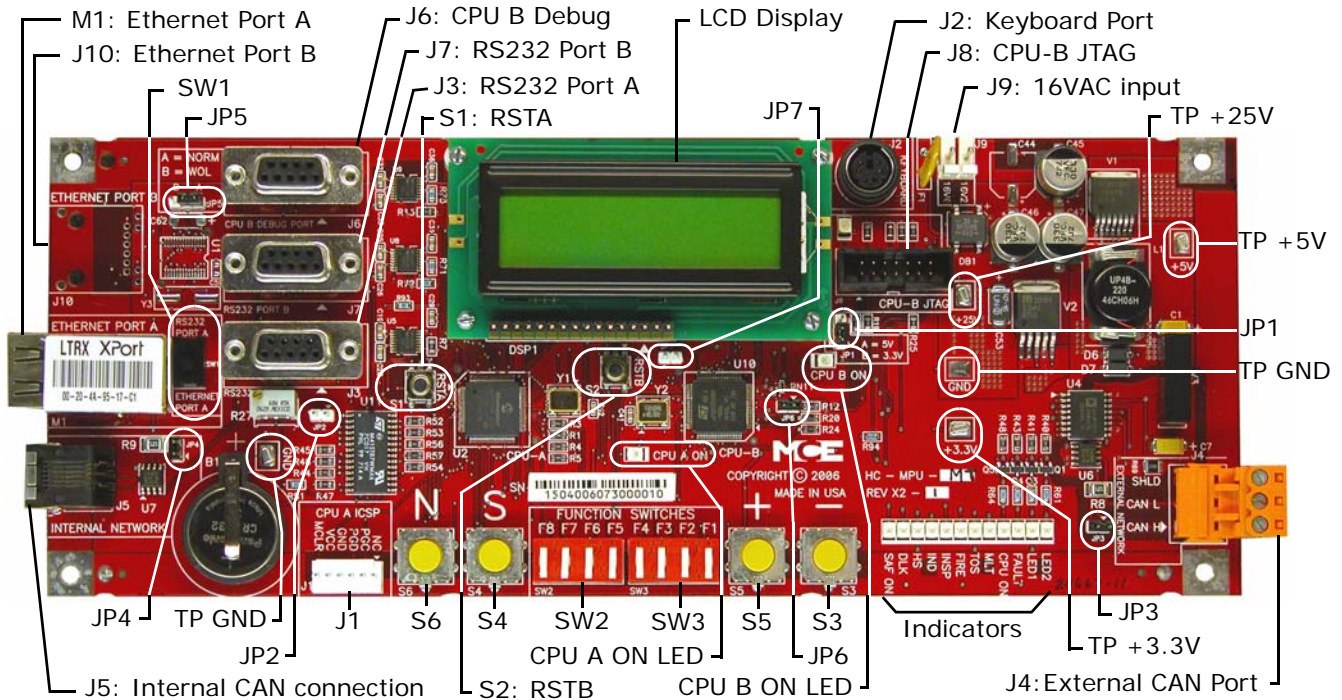

**Table 6.12 HC-MPU Board Jumpers**

Jumper	Setting	Description
JP1	A	Selects voltage for LCD. A = 5V, B = 3.3V
JP2	-	CPU A hard reset. No jumper provided, only required for 2K testing.
JP3	Closed	External CAN network termination.
JP4	Open	Internal CAN network termination
JP5	A	Ethernet Port B (not currently used)
JP6	Open	JTAG Debug Jumper. Closed = debug mode.
JP7	-	CPU B hard reset. No jumper provided, only required for 2K testing.

**Table 6.13 HC-MPU Board Switches**

Switches	Description
S1	RSTA: Reset CPU A
S2	RSTB: Reset CPU B
S3	"-" minus push button
S4	"S" push button
S5	"+" plus push button
S6	"N" push button
SW1	Port Selection: RS232 Port A / Ethernet Port A
SW2	DIP Function switches F5 through F8
SW3	DIP Function switches F1 though F4

**Table 6.14 HC-MPU Board Indicators**

Indicators	Description
CPU A ON	CPU A is executing its program
CPU B ON	CPU B is executing its program
LED2	Reserved
LED1	Reserved
FAULT	A fault has been detected.
CPU ON	All processors are fully functional.
MLT	Motor/Valve Limit Timer: The motor/valve limit timer has elapsed.
TOS	Timed Out of Service: The TOS timer has elapsed and the car is out of service.
FIRE	Fire Service: The car is on fire service operation.
INSP	Inspection: The car is on inspection operation.
IND	Independent Service: The car is on independent service.
HS	High Speed: The car is running at high speed.
DLK	Doors Locked: The door lock contacts are made.
SAF ON	Safety On: The safety circuit is made.

**Table 6.15 HC-MPU Board Test Points**

Test Points	Description
GND	0V
+3.3V	+3.3 Vdc measured between this test point and TP GND.
+5V	+5 Vdc measured between this test point and TP GND.
+25V	unregulated 25Vdc from the HC-CHP board



**Table 6.16 HC-MPU Board Terminals**

Connector	Description
J1	Used to program CPU A. IDC connector.
J2	Keyboard Port. Six pin DIN connector.
J3	RS-232 Port A. Nine pin D-sub connector.
J4	External CAN Port. Three pin Weidmuller connector (CAN H, CAN L, SHLD). Signal for CAN connections outside the controller cabinet.
J5	Internal CAN Port. RJ12 connector/cable to the HC-CHP CAN Hub / Power Supply board.
J6	CPU B Debug Port. Nine pin D-sub connector.
J7	RS-232 Port B. Nine pin D-sub connector.
J8	Used to program CPU B. Fourteen pin header connector.
J9	Low voltage AC input (16V). Two pin IDC connector.
J10	Optional Ethernet Port B. RJ45 connector.
M1	Ethernet Port A. Serial to ethernet conversion device.

**HC-MPU Battery**

The battery sustains volatile information when the power is off. Controller operating parameters are stored in non-volatile memory and will not be affected by battery removal. The battery provides 3.3 VDC. If battery voltage falls below 2.2 VDC, the battery should be replaced. If battery replacement is part of a regular maintenance schedule, we recommend it be replaced every two years.

**Table 6.17 HC-MPU Battery**

Type	Original Specification
Sanyo	CR2032, 3V, Mn D2-Li cell

**Replacement:**

1. Shut down power to the controller.
2. Replace the battery on the HC-MPU board.
3. Restore controller power.
4. Reset date and time. [Please refer to “Date/Time” on page 5-68.](#)

# HC-RDR Rear Door Board

The HC-RDR Rear Door board provides the interface and control for the rear doors.

**Figure 6.6** HC-RDR Rear Door Board

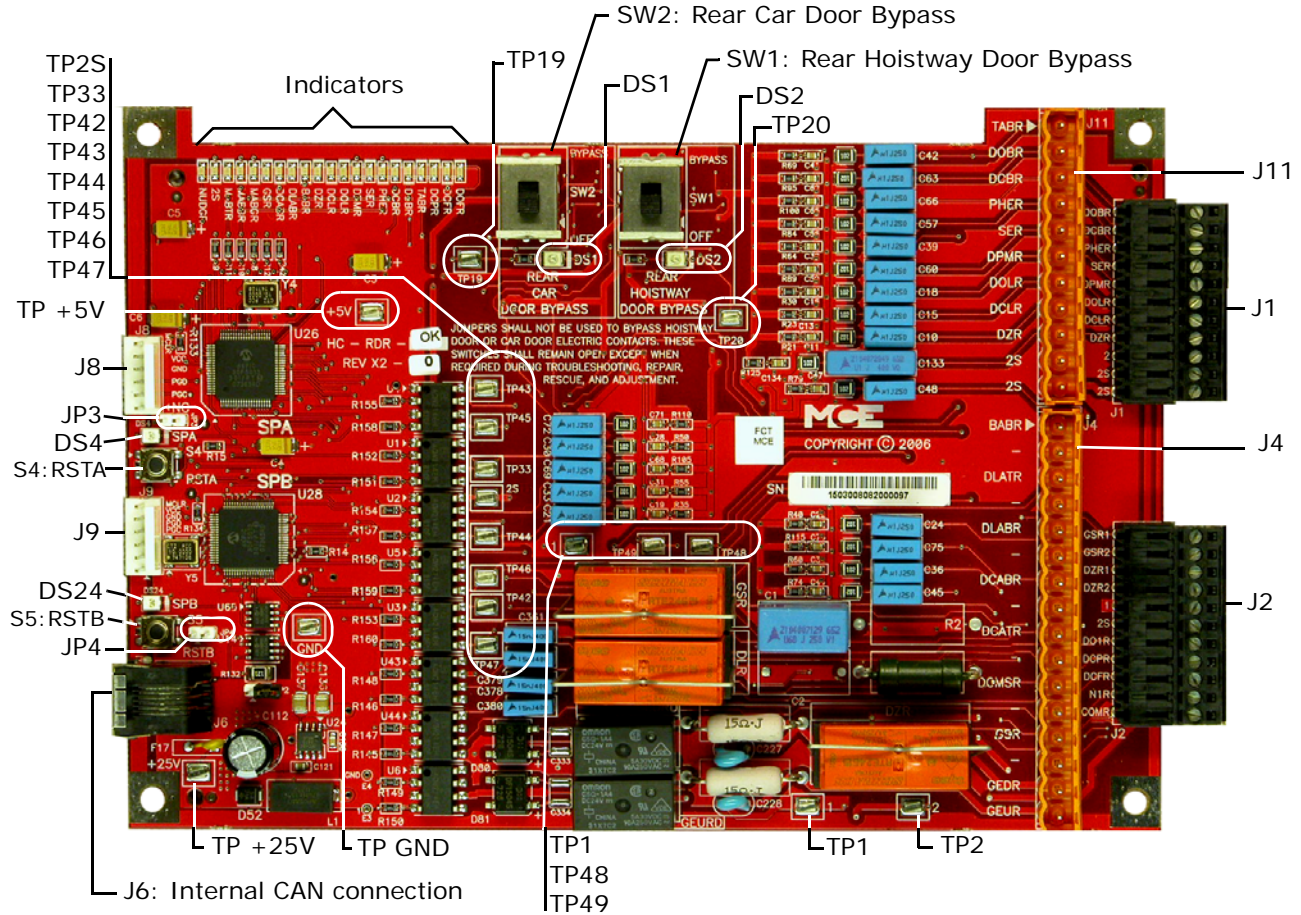

## Switches

- SW1: Rear Hoistway Door Bypass
- SW2: Rear Car Door Bypass
- S4: RSTA - Reset Safety Processor A
- S5: RSTB - Reset Safety Processor B

## Jumpers

- JP2: Internal CAN Network Termination - Open
- JP3: SPA hard reset. No jumper provided, jumper only required to perform 2K testing.
- JP4: SPB hard reset. No jumper provided, jumper only required to perform 2K testing.

## Relays

- DLR: Door Lock Relay
- DZR: Door Zone Relay
- GEDRD:
- GEURD:
- GSR: Gate Switch Relay

**Table 6.18 HC-RDR Board Terminals**

Connector	Terminal	Description
J1	DOBR	Door Open Button Rear (input)
	DCBR	Door Close Button Rear (input)
	PHER	Photo Eye Rear (input)
	SER	Safety Edge Rear (input)
	DPMR	Door Position Monitor Rear (input)
	DOLR	Door Open Limit Rear (input)
	DCLR	Door Close Limit Rear (input)
	DZR	Door Zone Rear (input)
	2	2 Bus
	2S	2S Bus
	2S	2S Bus
J2	GSR1	Gate Switch String from front doors (output)
	GSR2	Gate Switch String from front doors (input)
	DZR1	Door zone string from front doors (output)
	DZR2	Door zone string from front doors (input)
	1	1 Bus
	2S	2S bus feed (MCE wiring)
	DO1R	Rear door open function (output)
	DCPR	Door Close Power Rear (output)
	DCFR	Rear door Close function (output)
	N1R	Nudging operation (output)
	COMR	Common for DO1R, DCPR, DCFR, N1R
J4	BABR	Bottom access rear door lock bypass (input)
	-	No connection
	DLATR	Rear top door lock (input)
	-	No connection
	DLABR	Rear bottom door lock (input)
	-	No connection
	DCABR	Rear bottom retiring cam door lock (input)
	-	No connection
	DCATR	Rear top retiring cam door lock (input)
	-	No connection
	DCMSR	Rear middle retiring cam door lock (input)
	-	No connection
	GSR	Rear gate switch (input)
	-	No connection
	GEDR	Rear gong enable down (output)
GEUR	Rear gong enable up (output)	
J6		Internal CAN bus
J8		Used to program the SPA microcontroller
J9		Used to program the SPB microcontroller

**Table 6.18 HC-RDR Board Terminals**

Connector	Terminal	Description
J11	TABR	Top Access Rear Door Lock Bypass (input)
	DOBR	Door Open Button Rear (input)
	DCBR	Door Close Button Rear (input)
	PHER	Photo Eye Rear (input)
	SER	Safety Edge Eye Rear (input)
	DPMR	Door Position Monitor Rear (input)
	DOLR	Door Open Limit Rear (input)
	DCLR	Door Close Limit Rear (input)
	DZR	Door Zone Rear (input)
	2S	2S bus (output)
	2S	2S bus (output)

**Table 6.19 HC-RDR Board Indicators**

Indicator	Description
DOFR	Door Open Function Rear input is high
DCFR	Door Close Function Rear input is high
DCPR	Door Close Power Rear input is high
TABR	Top access rear door lock bypass input is high
DOBR	Door open button rear input is high
DCBR	Door close button rear input is high
PHER	Photo eye rear input is high
SER	Safety edge eye rear input is high
DPMR	Door position monitor rear input is high
DOLR	Door open limit rear input is high
DCLR	Door close limit rear input is high
DZR	Door zone rear input is high
BABR	Bottom access rear door lock bypass input is high
DLABR	Rear bottom door lock input is high
DCABR	Rear bottom retiring cam door lock input is high
GSR	Rear gate switch input is high
MABGR	Access Bypass Gate Rear monitor signal
MABBR	Access Bypass Bottom Rear monitor signal
MABTR	Access Bypass Top Rear monitor signal
2S	2S bus is high
NUDGR	Nudge Rear output on
DS1	Rear Car Door Bypass
DS2	Rear Hoistway Door Bypass
DS4	SPA
DS24	SPB

**Table 6.20 HC-RDR Board Test Points**

Test Points	Description
GND	0V
+5V	+5 Vdc measured between this test point and TP GND.
+25V	unregulated 25Vdc from the HC-CHP board
1	1 Bus (common)
2	2 Bus (120 Vac)
2S	2S Bus
19	120Vac = Car Door Bypass (input) is ON
20	120Vac = Hoistway Door Bypass (input) is ON
33	120Vac = Access Bypass gate (output) is ON
42	120Vac = Access Bypass Top (output) is ON
43	120Vac = Access Bypass Bottom (output) is ON
44	120Vac = Gate Switch Bypass (output) is ON
45	120Vac = Hoistway Door Bypass (output) is ON
46	120Vac = Top Access Bypass (output) is ON
47	120Vac = Bottom Access Bypass (output) is ON
48	120Vac = Gate Switch Relay is ON
49	120Vac = Door Lock Relay is ON



## HC-UIO Universal Input/Output Board

Depending upon the software installed, HC-UIO boards may be used for programmable inputs and outputs (16 per board), car and hall calls, door operator interface, or dispatching.

Figure 6.7 HC-UIO Universal Input/Output Board

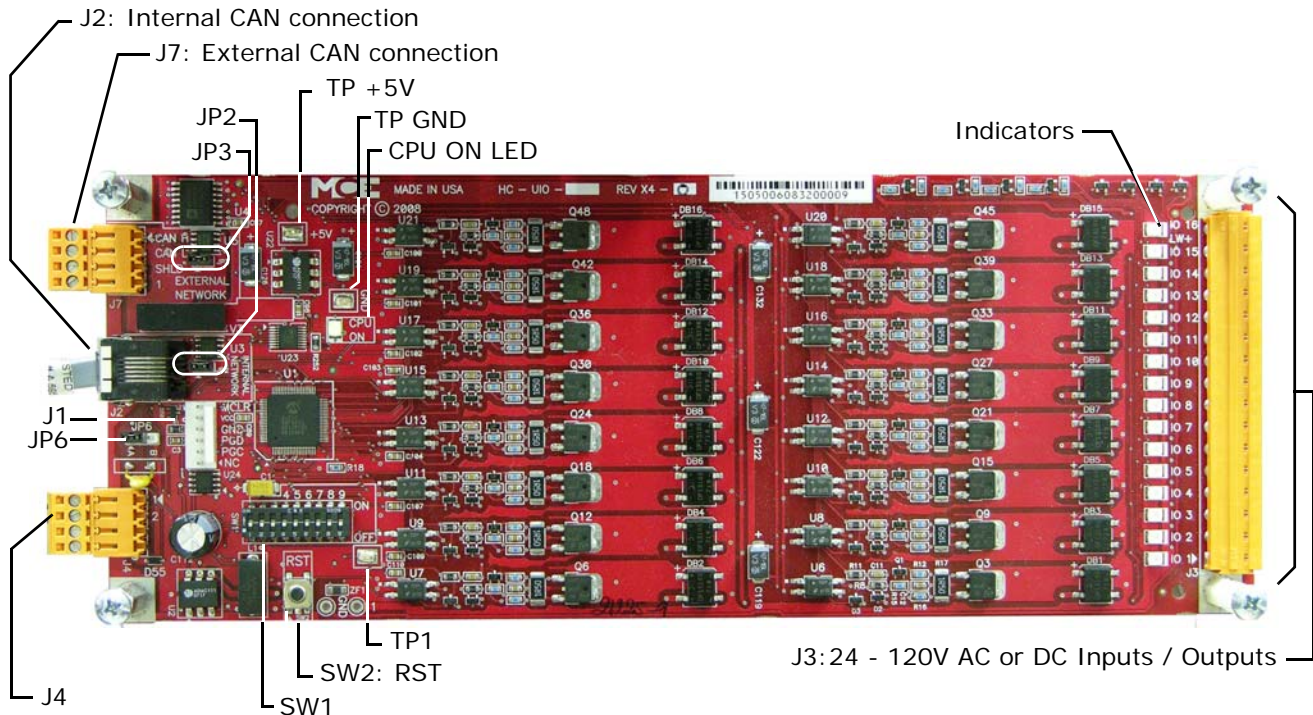

### Switches

- DIP SW1:
  - Switches 1 through 6 = Board ID (Please refer to “HC-UIO Board Call Assignments” on page 6-59) and (see “HC-UIO Spare Input / Output Assignments” on page 6-61)
  - Switches 7 & 8 = Baud rate (Please refer to “HC-UIO Spare Input / Output Assignments” on page 6-61)
  - Switch 9 = Input levels (Please refer to “HC-UIO Board DIP SW1 Switch 9 for Call Boards” on page 6-60)
- Sw2: RST - Processor reset

### Jumpers

- JP2: Internal CAN Network Termination
- JP3: External CAN Network Termination
- JP6: Selects voltage reference
  - A = 120Vac power supplied by J4 (default)
  - B = 24Vdc power supplied by CAN bus

### Test Points

- GND: Digital Ground - 0 V
- +5V: +5 Vdc measured between this test point and TP GND.
- 1: 1 Bus (common)

**Indicators**

- CPU ON: The microcontroller is executing its program.
- IO1 - IO16: Indicate the state of the input or output, active or inactive.

**Terminals**

- J1: Used to program the microcontroller (IDC connector).
- J2: Internal CAN signal and power (RJ12 connector).
- J3: IO1 - IO16. 24v to 120v AC or DC inputs or outputs.
- J4: 1 bus and 2 bus. Weidmuller connector.
- J7: External CAN Network (Weidmuller connector).

**Call Inputs and Outputs**

**Table 6.21 HC-UIO Board Call Assignments**

Board ID	SW1 Setting						IO 1 to IO 16
	1	2	3	4	5	6	
00	Off	Off	Off	Off	Off	Off	HC-UIO boards numbered 00 through 31 are used for call related IO. The associated SW1 switch setting is shown to the left. Terminal assignments, beginning with terminal IO 1 through IO 16 on board 00, followed by terminal IO 1 through IO 16 on board 01, etc., are made in the following order: nn = TOP LANDING SERVED • PIs PI1 - PI(nn) • Front car calls 101 - 1(nn) • Rear car calls 101R - 1(nn)R • Front down hall calls 502 - 5(nn) • Front up hall calls 601 - 6(nn-1) • Rear down hall calls 502R - 5(nn)R • Rear up hall calls 601R - 6(nn-1)R
01	On	Off	Off	Off	Off	Off	
02	Off	On	Off	Off	Off	Off	
03	On	On	Off	Off	Off	Off	
04	Off	Off	On	Off	Off	Off	
05	On	Off	On	Off	Off	Off	
06	Off	On	On	Off	Off	Off	
07	On	On	On	Off	Off	Off	
08	Off	Off	Off	On	Off	Off	
09	On	Off	Off	On	Off	Off	
10	Off	On	Off	On	Off	Off	
11	On	On	Off	On	Off	Off	
12	Off	Off	On	On	Off	Off	
13	On	Off	On	On	Off	Off	
14	Off	On	On	On	Off	Off	HC-UIO board terminal assignments are determined by the settings of the following BASIC FEATURE MENU (see page 5-14): • TOP LANDING SERVED? • HC-RDR BOARD ON THIS CAR? • CAR SERVES FRNT/FLR 1 (- 32)? • CAR SERVES REAR/FLR 1 (- 32)? And also (see page 5-19): • DISCRETE PI'S ON UIO? • DEDICATED PI BOARD? (allows first one or two UIO boards to be dedicated to PI's alone) • SERIAL COP BOARD HC-CPI?  The status of these terminals (On or Off) can be determined by observing the indicators on the HC-UIO boards. The status of the signals in the HC-MPU Main Processor memory can be observed as described in Troubleshooting Using External Memory Mode (see "Troubleshooting Using External Memory Mode" on page 5-56).
15	On	On	On	On	Off	Off	
16	Off	Off	Off	Off	On	Off	
17	On	Off	Off	Off	On	Off	
18	Off	On	Off	Off	On	Off	
19	On	On	Off	Off	On	Off	
20	Off	Off	On	Off	On	Off	
21	On	Off	On	Off	On	Off	
22	Off	On	On	Off	On	Off	
23	On	On	On	Off	On	Off	
24	Off	Off	Off	On	On	Off	
25	On	Off	Off	On	On	Off	
26	Off	On	Off	On	On	Off	
27	On	On	Off	On	On	Off	
28	Off	Off	On	On	On	Off	
29	On	Off	On	On	On	Off	
30	Off	On	On	On	On	Off	
31	On	On	On	On	On	Off	



### HC-UIO DIP SW1 Switches 7, 8 and 9 Settings

On the HC-UIO Board (Rev X4 and later), DIP SW1 switches 7 and 8 set the baud rate at which the CAN bus communicates with this board.

**Table 6.22 HC-UIO Board DIP SW1 Switches 7 and 8**

Sw 7	Sw 8	Baud Rate	Description
OFF	OFF	500 kbps	For boards inside the controller, RJ12 cable from J2 on HC-UIO board to HC-CHP board Internal Network J1 through J10.
ON	OFF	250 kbps	For boards on the cartop, RJ12 cable from J2 on HC-UIO board to MC-LSI board LAN connectors. <b>Caution:</b> Do not connect to J3 on the MC-LSI (Landing System) board.
OFF	ON	125 kbps	Future use

On the HC-UIO Board (Rev X4 and later), DIP SW1 switch 9 sets the activation threshold for inputs IO1 through IO16..

**Table 6.23 HC-UIO Board DIP SW1 Switch 9 for I/O Boards**

Sw 9	Description
OFF	Sets Input activation threshold to 18 Volts ac or dc
ON	Sets Input activation threshold to 55 to 65 Volts ac

**Table 6.24 HC-UIO Board DIP SW1 Switch 9 for Call Boards**

Sw 9	Description
OFF	Sets Input activation threshold to 0.6 Volts ac or dc
ON	Sets Input activation threshold to 0.2 Volts ac or dc

### HC-UIO Used for Calls

When HC-UIO boards are used for hall or car calls, the brightness of the LEDs associated with inputs and outputs has significance.

Level 0 - LED Off

- The input is not active and the output is not latched on.

Level 1 - LED medium brightness

- The input is not active and the output is latched on.

Level 2 - LED full brightness

- The input is active and the output may or may not be latched on.

### Hospital Emergency Operation I/O

I/O 1 through I/O 4 on UIO Board #16 are used for hospital emergency operation connections HEO, HWI, HSEL, and HOSPH2 respectively. [Please refer to “HOSPITAL EMERG. OPERATION?” on page 5-50.](#)



### Spare Inputs and Outputs

The Spare Inputs and Spare Outputs available on the Motion 2000 controller are described in Section 5 (see “Spare Inputs Menu Options” on page 5-29 and see “Spare Outputs Menu Options” on page 5-39). The first ten Spare Inputs (SP1 through SP10) are assigned to terminals SPIN1 through SPIN10 on the HC-CTL board (connectors J6 and J10). The first four Spare Outputs (OUT1 through OUT4) are assigned to terminals 1 through 4 (J15) on the HC-CTL board. The remainder of the Spare Inputs and Outputs are assigned to HC-UIO boards numbered 32 through 36 and shown in Table 6.21.

Table 6.25 HC-UIO Spare Input / Output Assignments

Board ID	SW1 Setting						IO Terminals								IO Terminals							
	1	2	3	4	5	6	1	2	3	4	5	6	7	8	9	10	11	12	13	14	15	16
32	Off	Off	Off	Off	Off	On	SP11	SP12	SP13	SP14	SP15	SP16	SP17	SP18	OUT5	OUT6	OUT7	OUT8	OUT9	OUT10	OUT11	OUT12
33	On	Off	Off	Off	Off	On	SP19	SP20	SP21	SP22	SP23	SP24	SP25	SP26	OUT13	OUT14	OUT15	OUT16	OUT17	OUT18	OUT19	OUT20
*34	Off	On	Off	Off	Off	On	SP27	SP28	SP29	SP30	SP31	SP32	SP33	SP34	OUT21	OUT22	OUT23	OUT24	OUT25	OUT26	OUT27	OUT28
*35	On	On	Off	Off	Off	On	SP35	SP36	SP37	SP38	SP39	SP40	SP41	SP42	OUT29	OUT30	OUT31	OUT32	OUT33	OUT34	OUT35	OUT36
36	Off	Off	On	Off	Off	On	SP43	SP44	SP45	SP46	SP47	SP48	SP49	SP50	OUT37	OUT38	OUT39	OUT40	OUT41	OUT42	OUT43	OUT44
37	On	Off	On	Off	Off	On																
38	Off	On	On	Off	Off	On																
39	On	On	On	Off	Off	On																
40	Off	Off	Off	On	Off	On																
41	On	Off	Off	On	Off	On																
42	Off	On	Off	On	Off	On																
43	On	On	Off	On	Off	On																
44	Off	Off	On	On	Off	On																
45	On	Off	On	On	Off	On																
46	Off	On	On	On	Off	On																
47	On	On	On	On	Off	On																
48	Off	Off	Off	Off	On	On																
49	On	Off	Off	Off	On	On																
50	Off	On	Off	Off	On	On																
51	On	On	Off	Off	On	On																
52	Off	Off	On	Off	On	On																
53	On	Off	On	Off	On	On																
54	Off	On	On	Off	On	On																
55	On	On	On	Off	On	On																
56	Off	Off	Off	On	On	On																
57	On	Off	Off	On	On	On																
58	Off	On	Off	On	On	On																
59	On	On	Off	On	On	On																
60	Off	Off	On	On	On	On																
61	On	Off	On	On	On	On																
62	Off	On	On	On	On	On																
63	On	On	On	On	On	On																

## MC-CPI Car Panel Interface Board

The MC-CPI board, mounted in the car operating panel, converts the discrete closures from the panel buttons and switches to data on the CAN serial bus and passes it through the MC-LSI Landing System Interface board on the cartop, up the traveler to the car controller. Additional MC-CPI boards are used to accommodate rear doors or installations with many floors, COP buttons, and lamps.

Spare assignable inputs to and outputs from CPI boards are available depending upon system configuration, front control panel only or front and rear control panels.

- F1 menu, Serial COP Board HC-CPI = YES and F1, HC-RDR Board on this Car = NO: CPI board assignable inputs show up in the Spare Inputs menu as CPI F (front panel board) I10 - I16; CPI FX (front panel extender board) I1 - I7. Spare outputs (Spare Outputs menu) will be prefaced with an 'O' for Output.
- F1 menu, Serial COP Board HC-CPI = YES and F1, HC-RDR Board on this Car = YES: CPI board assignable inputs show up in the Spare Inputs menu as CPI F (front panel board) I10 - I16 and CPI-R (rear panel board) I10 - I16. Spare outputs (Spare Outputs menu) will be prefaced with an 'O' for Output.

If the job has MC-CPI boards, unused spare inputs to and outputs from these boards must be set to NOT USED. If controller software is upgraded in the field, it is very important to check programmable CPI board inputs and outputs and verify unused connections are set to NOTUSED. [Please refer to "Spare Inputs Menu Options" on page 5-29.](#)



**Caution**

Spare inputs and outputs used on the CPI boards must be 24VDC, not to exceed 6 Watts.

### Installation Instructions

Please refer to the following instructions when installing the MC-CPI Car Panel Interface components.

1. Turn the power off at the main disconnect.
2. Mount the MC-CPI board(s) inside the COP using a combination of supplied hardware that will provide sufficient clearance for the components.
3. Refer to the job prints for your job when wiring the MC-CPI board. An example of a typical wiring print is included in this instruction ([Please refer to "Example: MC-CPI Wiring" on page 6-65](#) and see ["MC-CPI Serial Car Panel Interface Board" on page 6-63](#)).



**Caution**

This system is designed for 24 VDC circuits only! **Do not connect 120 VAC or DC to any terminal on the MC-CPI board.** Connect only the 24V power from connector J6 (24V CUSTOMER LOAD SUPPLY) to the load. ([Please refer to "MC-CPI Board Details" on page 6-64](#) and see ["Example: MC-CPI Wiring" on page 6-65](#)).

Figure 7. MC-CPI Serial Car Panel Interface Board

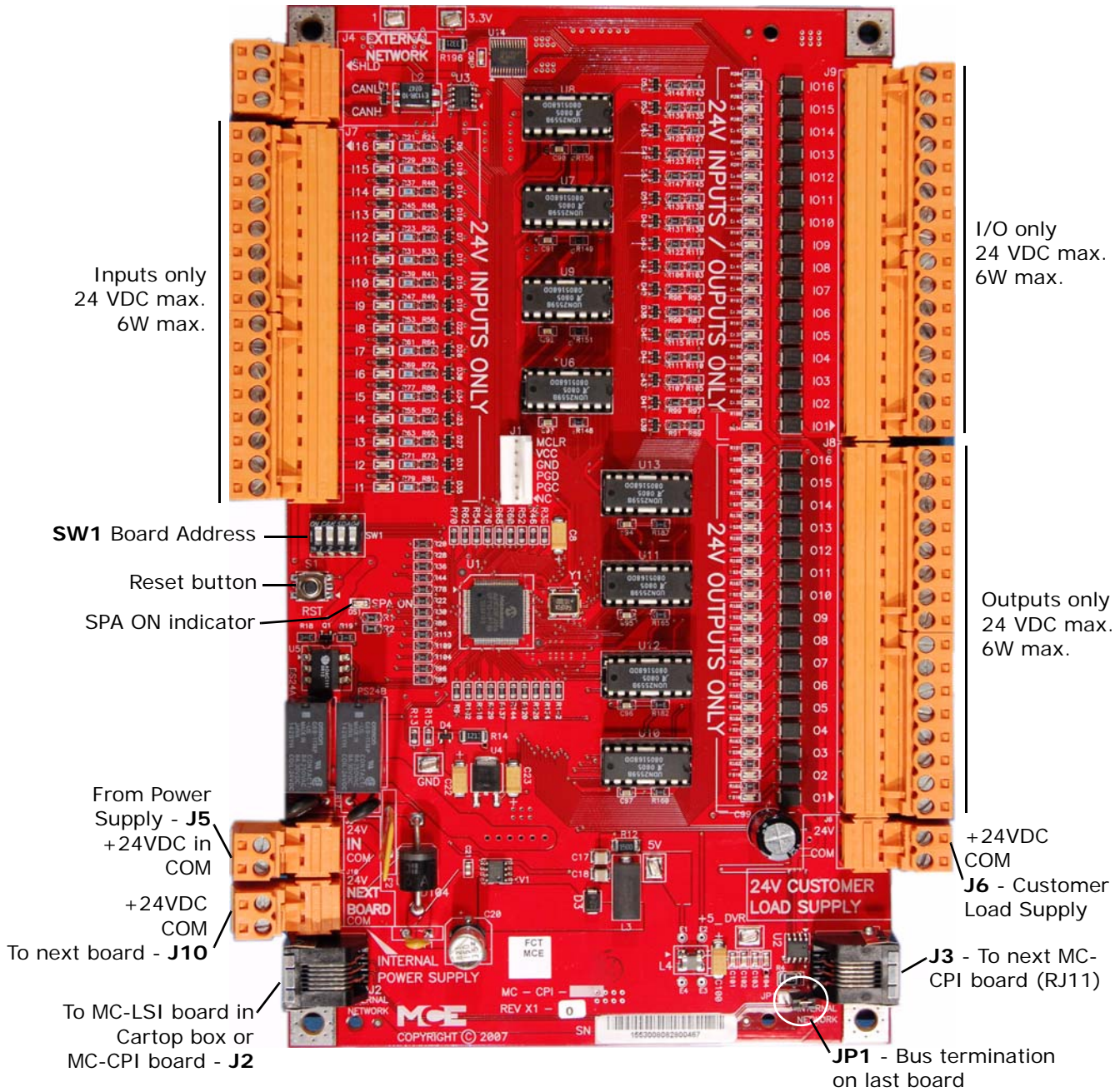

**Caution**

**This system is designed for 24 VDC circuits maximum. Do not connect 120VAC or DC to any terminal on this board at any time.**

### MC-CPI Board Details

- **24V Inputs Only:** Typical circuit for terminals I1 through I16.

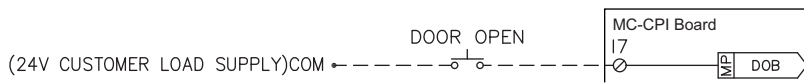

- **24V Outputs Only:** Typical circuit for terminals O1 through O16.



- **24V Inputs/Outputs Only:** Typical circuit for terminals IO1 through IO16.

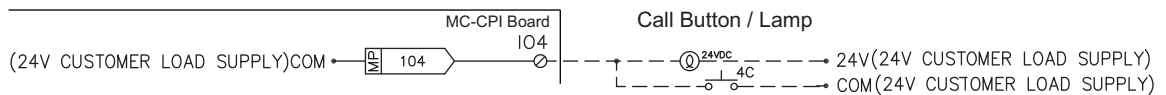

- **Board address switches:** Four-position DIP switch SW1 provides a unique address for each CPI board (you should never have two CPI boards with the same SW1 setting).



SW1	Front COP Boards				Rear COP Boards			
Board	DIP1	DIP2	DIP3	DIP4	DIP1	DIP2	DIP3	DIP4
1	Off	Off	Off	Off	Off	Off	On	Off
2	On	Off	Off	Off	On	Off	On	Off
3	Off	On	Off	Off	Off	On	On	Off
4	On	On	Off	Off	On	On	On	Off

- **24V Power:** The 24V power supply from the cartop box must be connected to the 24V IN connector on the first MC-CPI board. If additional boards are used, they are connected to 24V as shown below. Load connections (power source for buttons and switches in the car panel) can be made to any of the boards at the 24V CUSTOMER LOAD SUPPLY connector as long as load current at any one board is not more than 4A.
- **CAN Bus termination:** Jumper JP1 terminates the CAN bus in the correct impedance for CAN signal transmission. (If there is only one CPI board, it must have JP1 plugged in.)

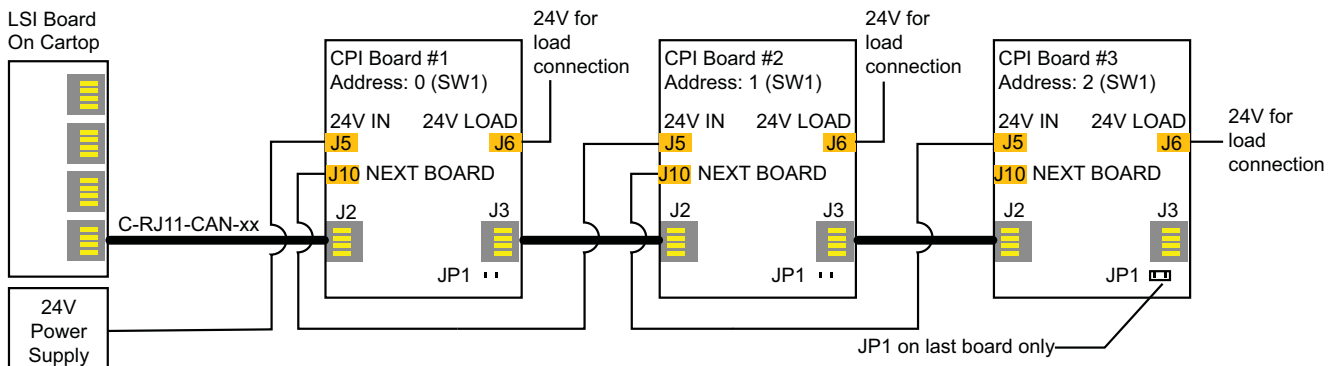

- **Verifying Cartop Communication:** Check for firmware versions for UIO 34 or UIO 35 (see “F8: Status Displays” on page 5-72). This usually indicates communication with the cartop.

Figure 6.1 Example: MC-CPI Wiring

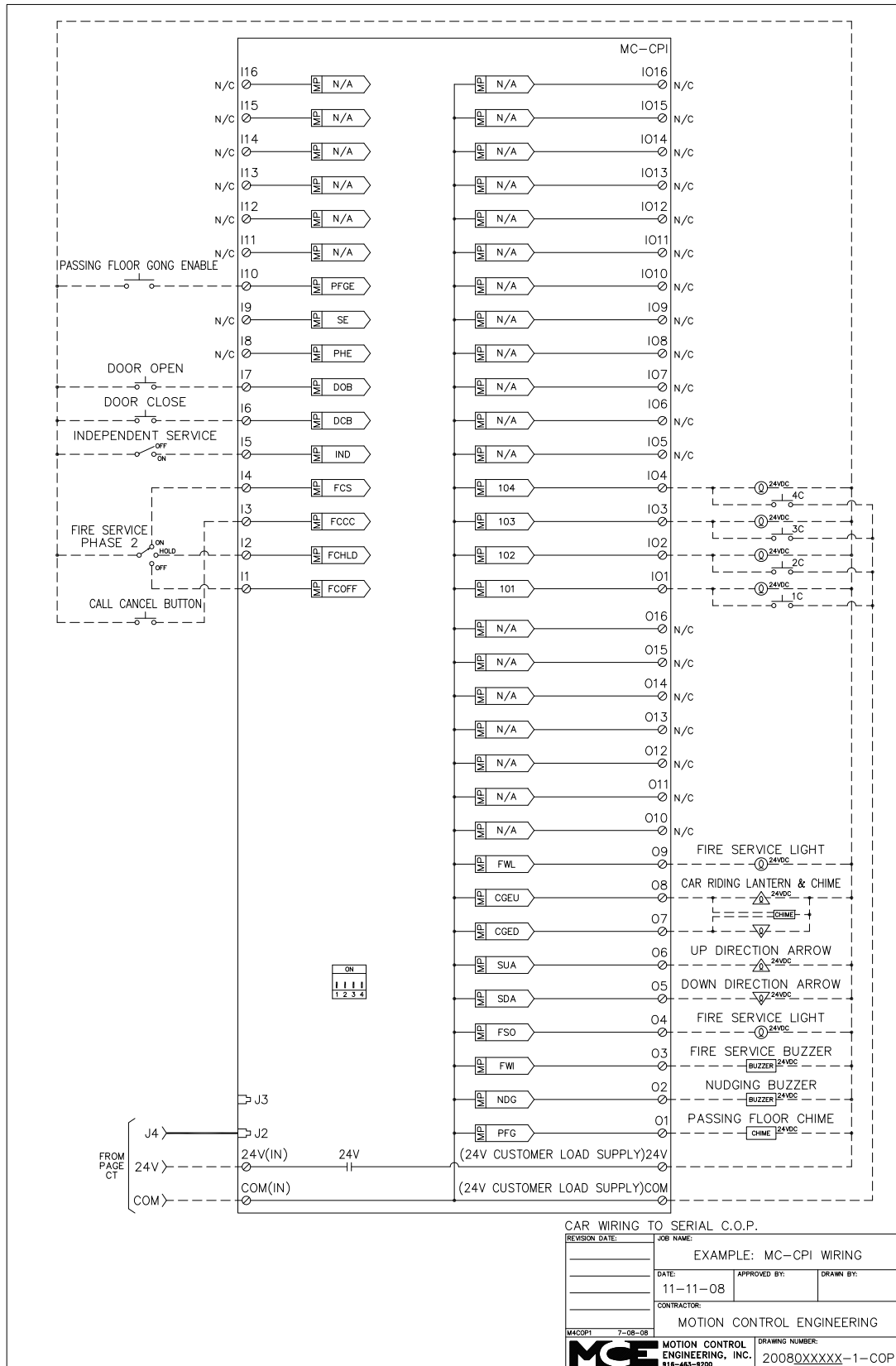

## Before Applying Power

Prior to applying power to the MC-CPI board(s):

1. Disconnect all terminal connectors from the MC-CPI boards (I/O connections, internal network and power connections (24V and COM terminals).
2. Apply power to the system.
3. Using a multimeter, check each of the wires to be connected to the MC-CPI boards as follows:
  - **Input circuits (switches, buttons, dry contacts):** Using the VDC setting referenced to 1 bus (common), probe each input circuit. The reading should be either 24VDC or floating.
  - **Output circuits (indicators, buzzers, chimes):** Using the VDC setting referenced to 1bus (common), probe each output circuit. The voltage reading should be approximately 24VDC.



### Caution

This system is designed for 24 VDC circuits only! **Do not connect 120 VAC or DC to any terminal on the MC-CPI board.** Connect only the 24V power from connector J6 (24V CUSTOMER LOAD SUPPLY) to the load ([Please refer to “MC-CPI Board Details” on page 6-64](#) and see [“Example: MC-CPI Wiring” on page 6-65](#)).

---

4. Power down the system.
5. Install the C-RJ11-CAN cable from J2 (Internal Network) on the MC-CPI board to the MC-LSI (Landing System Interface board) in the cartop box.
6. Install the MC-CPI board I/O connections (I/O terminals).
7. Install the MC-CPI board power connections (24V and COM terminals).



### Caution

To avoid damage to the MC-CPI boards, the system must be powered down before connecting and disconnecting the MC-CPI board power connections (unplugging and plugging in the 24V and COM terminals).

---

8. Apply power to the system and verify that:
  - The MC-CPI board SPA indicator is ON (green).
  - The relay closes and supplies 24VDC to the 24V CUSTOMER LOAD SUPPLY terminals.

## MC-LSI Landing System Interface Board

The MC-LSI mounts in the cartop box and provides a connection point for the landing system and for the Car Panel Interface board (MC-CPI) if one is used. The MC-LSI board receives 24 VAC power from an external transformer operating from the controller 2 Bus (120 VAC). In turn, the LSI board provides power to the landing system and to any Universal I/O boards that might be used on the cartop through the CAN connections to those components. A shielded, external CAN connection runs from the LSI board, through the traveler, to the Motion 4000 controller.

Figure 6.2 MC-LSI Landing System Interface Board

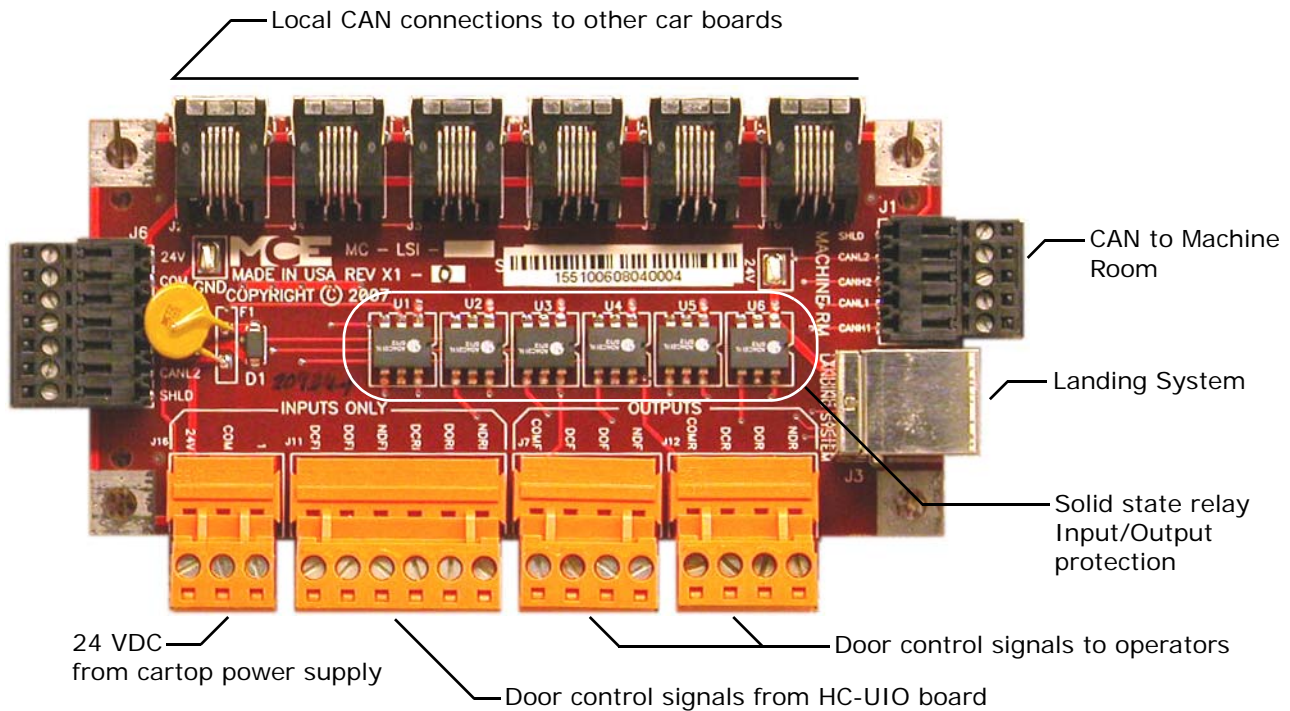

### LSI Connections

- Local CAN: CAN signal and power to additional cartop box boards (HC-UIO, MC-CPI, etc.)
- CAN to Machine Room: Redundant CAN connections to/from machine room
- Landing System: CAN connections to/from landing system
- Door Signals from cartop HC-UIO:
  - NDRI: Nudging, rear
  - DORI: Door open, rear
  - DCRI: Door close, rear
  - NDFI: Nudging, front
  - DOFI: Door open, front
  - DCFI: Door close, front
- Door Signals to operators:
  - NDR: Nudging, rear
  - DOR: Door open, rear
  - DCR: Door close, rear
  - COMR: Common
  - NDF: Nudging, front
  - DOF: Door open, front
  - DCF: Door close, front
  - COMF: Common

## SC-3HN Three Input Serial Hall Call Node Board

The SC-3HN board is used to provide serial hall calls for Motion controllers. The SC-3HN provides analog inputs and outputs for the hall call buttons and LEDs and a CAN connection to the Motion group. Refer to the drawings package for connection instructions to your fixtures.

Figure 6.3 SC-3HN Three Input Serial Hall Call Node Board

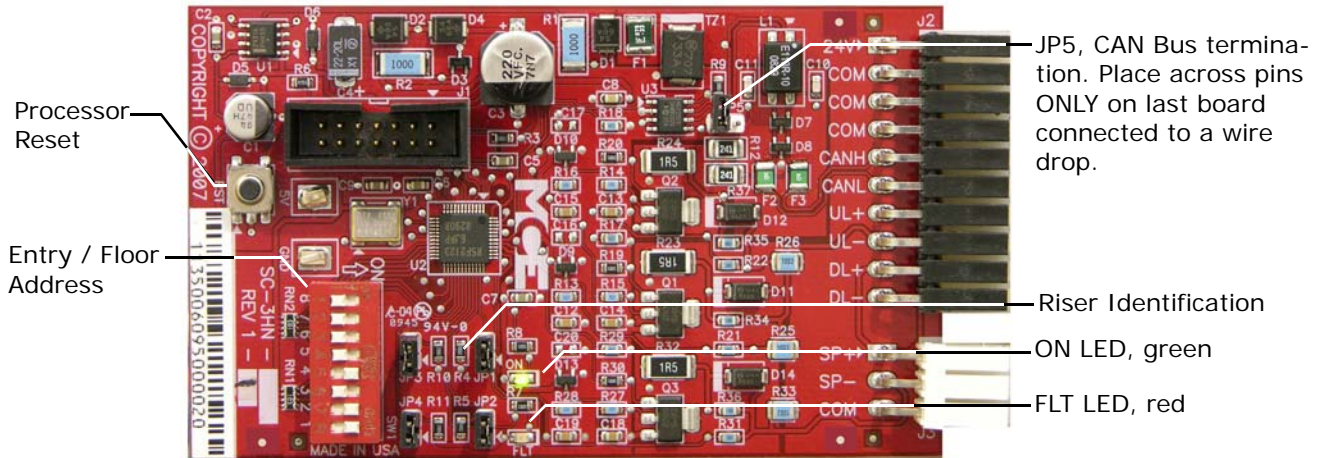

## Call Bus Conditions

In the dispatcher, the serial hall call CAN Bus originates on connectors J16 and/or J17 on the HC-CHP board. The two are electrically identical. If more than two physical connection points are required, a CAN Bus may be paralleled through the Panel Mount Terminal (PMT) strip. Refer to the drawings for the particular job.

- Eight risers are supported; four Main and four Auxiliary.
- Each hoistway wire drop consists of a twisted pair for signals and one wire each for 24V power and common. A wire drop can support more than one riser.
- Settings on each SC-3HN board determine which riser it belongs to, its floor address, and whether it is associated with the Front or Rear car entry.
- SC-3HN boards with the same floor address and entry association will register the same call and light indicators. Each must have a different riser ID but within the same riser group (Main or Auxiliary).
- Main risers A - D use riser IDs 7 - 4. Auxiliary risers A - D use riser IDs 3 - 0.

## General Installation

All SC-3HN connections are at one end of the board. One board is installed in each hall call panel electrical box. The board is shipped in an anti-static bag.

1. Make connections to the hall call buttons and indicators. (See following page.)
2. Make connections to the signal/power drop. (See following page.)
3. Set floor number and door (F/R) location, [6-70](#).
4. Set riser assignment, [6-70](#).
5. Last board on wire drop only: Place a jumper on JP5. All other boards: Ensure jumper NOT placed across JP5 pins, [6-70](#).
6. Insert board in anti-static sleeves and tape closed using supplied ESD sticker.
7. Tuck bag/board into electrical box and re-install hall call.



Figure 6.4 Hall Call Node Wiring

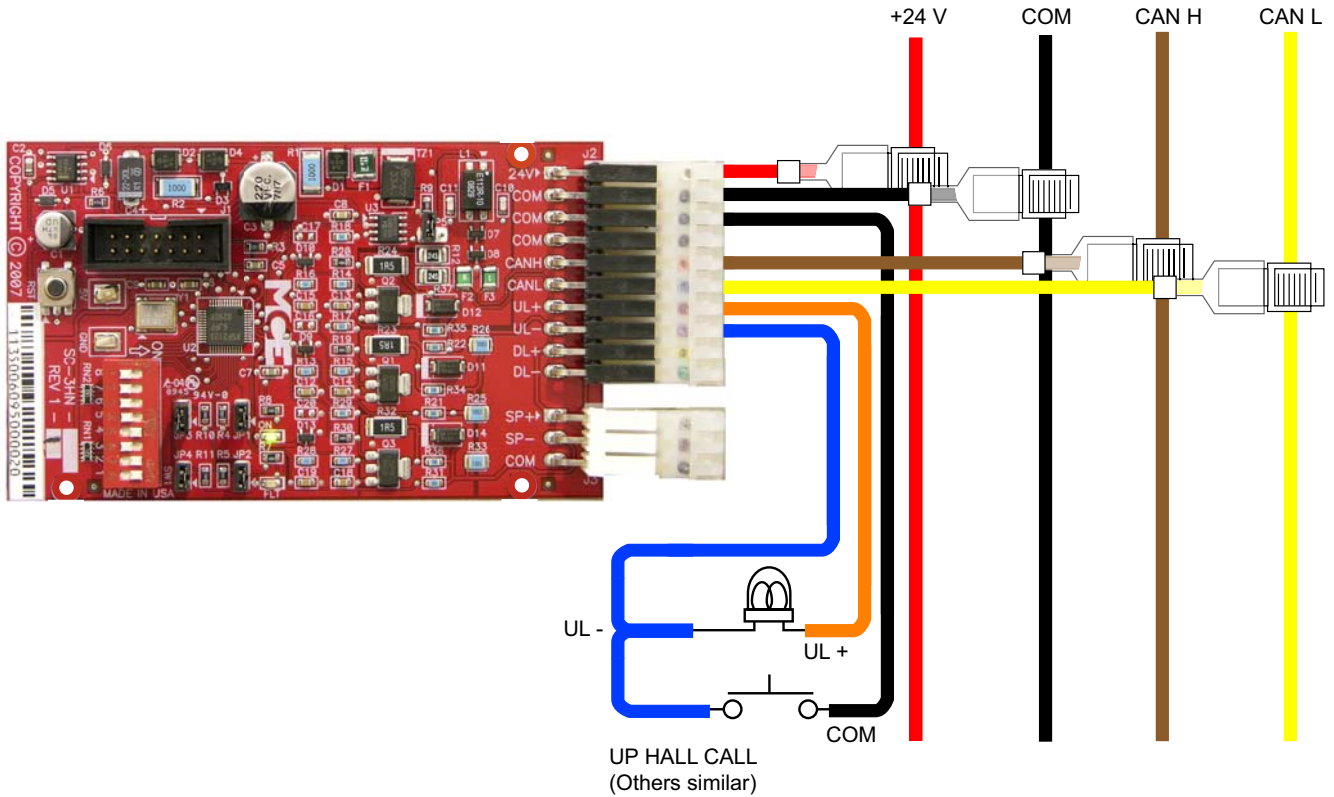

Table 6.26 Hall Wiring Colors

Color	Signal
red	+24V
black	common
brown	CAN H
yellow	CAN L
orange	UL+
blue	UL-
violet	DL+
green	DL-
gray	SP+
white	SP-

## Addressing and CAN Bus Termination

Set SC-3HN addresses as shown in the job prints for the installation. Generic examples are provided below.

### Riser Assignment

There are four Main risers and four Auxiliary risers. Jumper locations JP3, JP2, and JP1 are used to assign the appropriate riser to the SC-3HN board. In the following table, a “1” indicates a jumper in place.

**Table 6.27 Riser Assignment by Jumper Binary Representation**

JP3	JP2	JP1	Riser
1	1	1	Main A (Binary value 7)
1	1	0	Main B (Binary value 6)
1	0	1	Main C (Binary value 5)
1	0	0	Main D (Binary value 4)
0	1	1	Auxiliary A (Binary value 3)
0	1	0	Auxiliary B (Binary value 2)
0	0	1	Auxiliary C (Binary value 1)
0	0	0	Auxiliary D (Binary value 0)

### Floor Number and Front or Rear Opening

DIP switch SW1, switches 1 through 7 set the floor address for the board, beginning with Floor 1. Switch 8 selects Front or Rear opening.

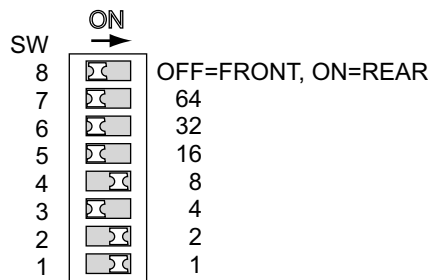

When setting addresses, use the values silk-screened on the circuit board, not those shown on the DIP switch.

Floor address example = 11

ON switch adds its value to floor address.

### Baud Rate

Jumper JP4 is reserved for future use to select a different CAN Bus baud rate should it become necessary. For now, the only option is to leave the JP4 jumper in place, setting baud rate to 125 kbps.

### CAN Bus Termination

The CAN Bus must be terminated **ONLY ON THE LAST SC-3HN** connected to the wire drop (farthest board from Dispatcher).



JP5 OFF/Unterminated  
All but last board

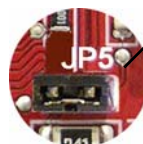

JP5 ON/Terminated  
Last board on wire drop ONLY.

## On Board Diagnostics

Two LEDs provide diagnostic information: The ON LED (green) and the FLT LED (red).

### ON LED

The ON LED reflects power/communications status.

- ON: Group communications OK
- OFF: Board is not receiving power or has no software loaded.
- Blinking: Communications error - more than ten seconds have passed without a message from the group dispatcher.

### (FLT) FAULT LED

The FLT LED reflects the status of the analog outputs.

- ON steady: Internal fault -
  - Replace board if problem persists
- OFF: No Errors detected.
- Blinking: Output overload or disconnection. Pressing the Reset button on the SC-3HN board will clear a blinking Fault LED.
  - Overload: Excessive current draw. Resets when current draw is corrected and call button is pressed again.
  - Not Connected: The output is on (button pressed) but nothing is connected to the UL- or DL- output. Resets when the lamp is connected and the call button is pressed again.
  - Output Shorted: If short is very quick, the LED will flash. Pressing the call button for a few moments will cause the board to reboot. Resets when the short is removed and the call button is pressed again.



#### Note

Please refer to the Motion Group Manual, 42-02-G006, for configuration information relating to hall calls.

## Using the MLT / VLT Data Trap

The MLT / VLT “data trap” records many of the controller's operation “flags” at the moment the MLT or VLT occurs. This allows you to see what flags led up to the fault. Note: Direction must be on (input UPS) for the adjustable time set via parameter MOTOR LIMIT TIMER (1 - 6 minutes) before MLT will occur. Direction must be on (input DNS) for the adjustable time set via parameter VALVE LIMIT TIMER (1 - 6 minutes) before VLT will occur.

Once an MLT or VLT shuts down the car, use these steps to look at the stored flags.

1. Do not reset the computer as this will clear the data trap on software version 5.19.0001 or earlier. To return the car to service and not harm the data, simply toggle the relay panel inspection switch from OFF to ON and back to OFF.



### Note

The data is not cleared on power up or reset. The data is overwritten each time a new MLT occurs. However, the data may be cleared and the MLT counter reset by placing the F1, F2, F7 and F8 switches in the up position.

2. On the HC-MPU board place the F2 switch up (ON) to select External Memory. All other switches should be down (OFF). The LCD display shows the default address, DA.0100 (address 100 Hex) followed by the eight memory bits at that location.
3. Use the DATA TRAP MEMORY CHART to determine the addresses where the saved data is stored. The section in the Controller Installation Manual titled EXTERNAL MEMORY MODE provides a complete description of how to use the External Memory Mode. Briefly, use the **N** push button to select the digit to be changed (digit blinks on and off). Press + or - to change the digit.
4. Record the data displayed on the LCD for all rows shown on the chart. It helps if you have a few photocopies of the chart. Simply mark the positions in the chart that are shown as a “1” on the LCD display. Addresses 0480 through 0493 contain car status flags. Address 0494 contains the car's position indicator value at the instant the MLT or VLT condition occurred and address 0495 contains the MLT counter. Only the labeled positions are important to mark.
5. Use the recorded values and the timer logic flowcharts to help determine the cause of the problem. Then call MCE for assistance if any is needed.



### Note

\* Note: To determine the software version, place switch F8 up (ON) with all other function switches down (OFF).

## PHC Hydro Data Trap Memory Chart

Hex	Diagnostic Indicators							
Address	8	7	6	5	4	3	2	1
0480	DOLM On / Off	PHE On / Off	DZ On / Off	DOL On / Off	DBC On / Off	DOB On / Off	GEU On / Off	GED On / Off
0481	TFA On / Off	DC On / Off	UC On / Off	CC On / Off	NDS On / Off	FDC On / Off	DHO On / Off	DOI On / Off
0482	DCFN On / Off	DCP On / Off	DOF On / Off	LOT On / Off	GHT On / Off	HCT On / Off	CCT On / Off	SDT On / Off
0483	DOC On / Off	SE On / Off	DCLC On / Off	CSB On / Off	DCC On / Off	NUDG On / Off	NUGBPS On / Off	DSHT On / Off
0484	VCI On / Off	FRA On / Off	FCS On / Off	FRS On / Off	DNS On / Off	UPS On / Off	STD On / Off	STU On / Off
0485	SCE On / Off	FCCC On / Off	FCHLD On / Off	HLI On / Off	VCA On / Off	EXMLT On / Off	FWI On / Off	PIC On / Off
0486	LFP On / Off	UFP On / Off	NYDS On / Off	CCH On / Off	DIN On / Off	DPR On / Off	GTDE On / Off	GTUE On / Off
0487	HD On / Off	FCOFF On / Off	DHLD On / Off	IND On / Off	IN On / Off	DLKS On / Off	MLTP On / Off	MLTDO On / Off
0488	LLW On / Off	DLK On / Off	DDF On / Off	SUD On / Off	ISR On / Off	INCF On / Off	REAR On / Off	LLI On / Off
0489	DNDO On / Off	LD On / Off	DPD On / Off	DDP On / Off	UPDO On / Off	LU On / Off	UPD On / Off	UDP On / Off
048A	DMD On / Off	DCB On / Off	UCB On / Off	CCB On / Off	DMU On / Off	DCA On / Off	UCA On / Off	CCA On / Off
048B	TOS On / Off	MLT On / Off	VLT On / Off	SST On / Off	H On / Off	HSEL On / Off	DSH On / Off	RUN On / Off
048C	DZP On / Off	STC On / Off	SAF On / Off	HCR On / Off	HCDX On / Off	CCD On / Off	ISV On / Off	ISRT On / Off
048D	TEMPB On / Off	UFQ On / Off	DZORDZ On / Off	FCSM On / Off	FRM On / Off	FRSS On / Off	FRAS On / Off	FRC On / Off
048E	SD On / Off	SDA On / Off	DSD On / Off	BFD On / Off	SU On / Off	SUA On / Off	USD On / Off	TFD On / Off
048F	FRBYP On / Off	FRON On / Off	HYD1_TRC0 On / Off	ECC On / Off	CD On / Off	ECRN On / Off	EPR On / Off	PFG On / Off
0490	CODE4 On / Off	CODE2 On / Off	CODE3 On / Off	FREE On / Off	DEADZ On / Off	DHLD1 On / Off	PH1 On / Off	NDGF On / Off
0491	CTLDOT On / Off	CTLF On / Off	CTL On / Off	ALV On / Off	EPSTP On / Off	AUTO On / Off	EPRUN On / Off	EPI On / Off
0492	FRMM On / Off	OFR On / Off	WLDI On / Off	WLD On / Off	CCMEM On / Off	OLW On / Off	OVLM On / Off	OVL On / Off
0493	API On / Off	SAB On / Off	TEST On / Off	DHENDR On / Off	DHEND On / Off	CTST On / Off	HOSPH2 On / Off	HOSP On / Off
0494	PI On / Off	PI On / Off	PI On / Off	PI On / Off	PI On / Off	PI On / Off	PI On / Off	PI On / Off
0495	LOS On / Off	±	±	±	MLT Counter On / Off	MLT Counter On / Off	MLT Counter On / Off	MLT Counter On / Off





## Quick Topics

- In this Section
- Parameter Settings Record
- Elevator Security Information
- LS-QUTE Assembly



## Appendix

7

### In this Section

- **Motion 2000 Parameter Settings Record:** Use this table to record the original parameter values and any changes made to these values (see [page 7-2](#)).
- **Elevator Security Information and Operation:** Use this form to record information about building security and the programmed security codes. This form may be given to building tenants (see [page 7-10](#)).
- **LS-QUTE landing System Assembly Drawings:** Assembly and wiring drawings for the LS-QUTE Landing System (see [page 7-12](#)).

## Motion 2000 Parameter Settings Record

This form is provided for recording the current parameter settings on your Motion 2000 controller. If the firmware is upgraded or parameters are re-set to default values, you can then compare the parameter settings to this record to verify that they are correct.

**Job Number:** \_\_\_\_\_ **Date:** \_\_\_\_\_ **Bootrom Ver#** \_\_\_\_\_

**Job Name:** \_\_\_\_\_ **Car Number:** \_\_\_\_\_

**Table 1. Firmware Versions (F8) and (F1 and F8)**

Function Switch	Processor	Current Version	New Version
F8	MPU B	R____ Ver# H____.____.____	R____ Ver# H____.____.____
F1 & F8	MPU A		
F1 & F8	CTL A		
F1 & F8	CTL B		
F1 & F8	CTL C		
F1 & F8	RDR A		
F1 & F8	RDR B		
F1 & F8	UIO		
F1 & F8	CHP		
F1 & F8	DVR		

**Table 2. Floor and Message Labels (F4)**

Landing/ Msg #	Floor Label	Msg Label	Landing/ Msg #	Floor Label	Msg Label	Landing/ Msg #	Floor Label	Msg Label	Landing/ Msg #	Floor Label	Msg Label
01			11			21			31		
02			12			22			32		
03			13			23					
04			14			24					
05			15			25					
06			16			26					
07			17			27					
08			18			28					
09			19			29					
10			20			30					



Program Mode (F1) Parameter Settings Record

Program Mode (F1) Parameter Settings Record		
OPTIONS	CURRENT VALUES	NEW VALUES
<b>BASIC FEATURES</b>		
Controller Type:	<input type="checkbox"/> Hydro (M2000) <input type="checkbox"/> Traction (M4000)	<input type="checkbox"/> Hydro (M2000) <input type="checkbox"/> Traction (M4000)
Simplex / Local or Duplex?	<input type="checkbox"/> Simplex <input type="checkbox"/> Local <input type="checkbox"/> Duplex	<input type="checkbox"/> Simplex <input type="checkbox"/> Local <input type="checkbox"/> Duplex
Operation:	<input type="checkbox"/> Sel. Coll. <input type="checkbox"/> Single Button <input type="checkbox"/> Single Auto PB	<input type="checkbox"/> Sel. Coll. <input type="checkbox"/> Single Button <input type="checkbox"/> Single Auto PB
Top Landing Served (This car)?		
HC-RDR Board on this Car (This car)	<input type="checkbox"/> Yes <input type="checkbox"/> No	<input type="checkbox"/> Yes <input type="checkbox"/> No
Car Serves Frnt/Flr (This car)?	1 2 3 4 5 6 7 8 10 11 12 13 14 15 16 17 18 19 20 21 22 23 24 25 26 27 28 29 30 31 32	1 2 3 4 5 6 7 8 10 11 12 13 14 15 16 17 18 19 20 21 22 23 24 25 26 27 28 29 30 31 32
Car Serves Rear/Flr (This car)?	1 2 3 4 5 6 7 8 10 11 12 13 14 15 16 17 18 19 20 21 22 23 24 25 26 27 28 29 30 31 32	1 2 3 4 5 6 7 8 10 11 12 13 14 15 16 17 18 19 20 21 22 23 24 25 26 27 28 29 30 31 32
Top Landing Served (Other car)?		
HC-RDR Board on this Car (Other car)	<input type="checkbox"/> Yes <input type="checkbox"/> No	<input type="checkbox"/> Yes <input type="checkbox"/> No
Other Car Serves Frnt/Flr?	1 2 3 4 5 6 7 8 10 11 12 13 14 15 16 17 18 19 20 21 22 23 24 25 26 27 28 29 30 31 32	1 2 3 4 5 6 7 8 10 11 12 13 14 15 16 17 18 19 20 21 22 23 24 25 26 27 28 29 30 31 32
Other Car Serves Rear/Flr?	1 2 3 4 5 6 7 8 10 11 12 13 14 15 16 17 18 19 20 21 22 23 24 25 26 27 28 29 30 31 32	1 2 3 4 5 6 7 8 10 11 12 13 14 15 16 17 18 19 20 21 22 23 24 25 26 27 28 29 30 31 32
Parking Floor		
Alt. Parking Floor		
Secondary Park Floor		
Lobby Floor		
Car Identifier	Set first car to A, next car to B, etc.	Set first car to A, next car to B, etc.
Serial COP Board HC-CPI?	<input type="checkbox"/> Yes <input type="checkbox"/> No	<input type="checkbox"/> Yes <input type="checkbox"/> No
Discrete PIs on UIO?	<input type="checkbox"/> Yes <input type="checkbox"/> No	<input type="checkbox"/> Yes <input type="checkbox"/> No
Dedicated PI Board?	<input type="checkbox"/> Yes <input type="checkbox"/> No	<input type="checkbox"/> Yes <input type="checkbox"/> No
Serial Cartop Door CNTRL?	<input type="checkbox"/> Yes <input type="checkbox"/> No	<input type="checkbox"/> Yes <input type="checkbox"/> No
Disable Local Hall Calls?	<input type="checkbox"/> Yes <input type="checkbox"/> No	<input type="checkbox"/> Yes <input type="checkbox"/> No
<b>FIRE SERVICE</b>		
Fire Service Operation?	<input type="checkbox"/> Yes <input type="checkbox"/> No	<input type="checkbox"/> Yes <input type="checkbox"/> No
Fire Phase 1 Main Floor		
Fire Phase 1 Alt. Floor		
Fire Service Code		
Fire Phase 1, 2 <sup>nd</sup> Alt Landing		
Will This Car Run on PH2?	<input type="checkbox"/> Yes <input type="checkbox"/> No	<input type="checkbox"/> Yes <input type="checkbox"/> No
Bypass Stop Sw. on Phase 1?	<input type="checkbox"/> Yes <input type="checkbox"/> No	<input type="checkbox"/> Yes <input type="checkbox"/> No
Honeywell Fire Operation?	<input type="checkbox"/> Yes <input type="checkbox"/> No	<input type="checkbox"/> Yes <input type="checkbox"/> No
NYC Fire Phase 2 and ANSI 89?	<input type="checkbox"/> Yes <input type="checkbox"/> No	<input type="checkbox"/> Yes <input type="checkbox"/> No
White Plains, NY Fire Code?	<input type="checkbox"/> Yes <input type="checkbox"/> No	<input type="checkbox"/> Yes <input type="checkbox"/> No
Mass 524 CMR Fire Code?	<input type="checkbox"/> Yes <input type="checkbox"/> No	<input type="checkbox"/> Yes <input type="checkbox"/> No
ASME A17.1A 2000 Addenda?	<input type="checkbox"/> None <input type="checkbox"/> 2005 <input type="checkbox"/> 2007	<input type="checkbox"/> None <input type="checkbox"/> 2005 <input type="checkbox"/> 2007
Disable DPM on Fire PH.2?	<input type="checkbox"/> Yes <input type="checkbox"/> No	<input type="checkbox"/> Yes <input type="checkbox"/> No
Low Voltage Fire Sensor?	<input type="checkbox"/> Yes <input type="checkbox"/> No	<input type="checkbox"/> Yes <input type="checkbox"/> No
Latch Flashing Fire Hat?	<input type="checkbox"/> Yes <input type="checkbox"/> No	<input type="checkbox"/> Yes <input type="checkbox"/> No
<b>DOOR OPERATION</b>		
Nudging?	<input type="checkbox"/> Yes <input type="checkbox"/> No	<input type="checkbox"/> Yes <input type="checkbox"/> No
Stuck Photo Eye Protection?	<input type="checkbox"/> Yes <input type="checkbox"/> No	<input type="checkbox"/> Yes <input type="checkbox"/> No
Sequential Door Oper.(F/R)?	<input type="checkbox"/> Yes <input type="checkbox"/> No	<input type="checkbox"/> Yes <input type="checkbox"/> No
Car Call Cancels Door Time?	<input type="checkbox"/> Yes <input type="checkbox"/> No	<input type="checkbox"/> Yes <input type="checkbox"/> No
Nudging During Fire Phase 1?	<input type="checkbox"/> Yes <input type="checkbox"/> No	<input type="checkbox"/> Yes <input type="checkbox"/> No
Retiring Cam Option?	<input type="checkbox"/> Yes <input type="checkbox"/> No	<input type="checkbox"/> Yes <input type="checkbox"/> No
Pre-Opening?	<input type="checkbox"/> Yes <input type="checkbox"/> No	<input type="checkbox"/> Yes <input type="checkbox"/> No
Mechanical Safety Edge?	<input type="checkbox"/> Yes <input type="checkbox"/> No	<input type="checkbox"/> Yes <input type="checkbox"/> No
Nudging Output/Buzzer Only?	<input type="checkbox"/> Yes <input type="checkbox"/> No	<input type="checkbox"/> Yes <input type="checkbox"/> No



### Program Mode (F1) Parameter Settings Record

OPTIONS	CURRENT VALUES	NEW VALUES
D.C.B. Cancels Door Time?	___ Yes ___ No	___ Yes ___ No
Leave Door Open on MGS (Traction only)	___ Yes ___ No	___ Yes ___ No
Leave Door Open on PTI/ESS?	___ Yes ___ No	___ Yes ___ No
Nudging During Fire Phase 2?	___ Yes ___ No	___ Yes ___ No
Dir. Preference Until DLK?	___ Yes ___ No	___ Yes ___ No
Fully Manual Doors?	___ Yes ___ No	___ Yes ___ No
Cont. D.C.B. to Close Doors?	___ Yes ___ No	___ Yes ___ No
Cont. D.C.B. for Fire Phase 1?	___ Yes ___ No	___ Yes ___ No
Moment. D.O.B. door opening? Moment D.O.B. for: Moment D.O.B. for:	___ No ___ Front ___ Rear ___ Both Doors ___ Hall Calls ___ Car Calls ___ All Calls	___ No ___ Front ___ Rear ___ Both Doors ___ Hall Calls ___ Car Calls ___ All Calls
Doors to open if parked?	___ None ___ Front ___ Rear ___ Both	___ None ___ Front ___ Rear ___ Both
Doors to Open on Main Fire?	___ Front ___ Rear ___ Both	___ Front ___ Rear ___ Both
Doors to Open on Alt. Fire?	___ Front ___ Rear ___ Both	___ Front ___ Rear ___ Both
Leave Doors Open on CTL	___ Yes ___ No	___ Yes ___ No
Limited Door Re-Open Option	___ Yes ___ No	___ Yes ___ No
Reduce HCT with Photo Eye	___ Yes ___ No	___ Yes ___ No
Leave Doors Open on EPI	___ Yes ___ No	___ Yes ___ No
Doors to open if No demand?	___ None ___ Front ___ Rear ___ Both	___ None ___ Front ___ Rear ___ Both
Const. Press Op. Bypass PHE?	___ Yes ___ No	___ Yes ___ No
Door Type is?	___ Horizontal ___ Vertical	___ Horizontal ___ Vertical
Front Door Mech. Coupled?	___ Yes ___ No	___ Yes ___ No
Rear Door Mech. Coupled?	___ Yes ___ No	___ Yes ___ No
Prevent DCP Till Doors Close:	___ Yes ___ No	___ Yes ___ No
Moment D.C.B to Close Doors?	___ Yes ___ No	___ Yes ___ No
Doors to Latch DOF?	___ None ___ Front ___ Rear ___ Both	___ None ___ Front ___ Rear ___ Both
Doors to Latch DCF?	___ None ___ Front ___ Rear ___ Both	___ None ___ Front ___ Rear ___ Both
Inv. Door Closed Limit?	___ None ___ Front ___ Rear ___ Both	___ None ___ Front ___ Rear ___ Both
Fire PH2. with Doors Closed	___ Yes ___ No	___ Yes ___ No
<b>TIMER</b>		
Short Door Timer	___ seconds	___ seconds
Car Call Door Timer	___ seconds	___ seconds
Hall Call Door Timer	___ seconds	___ seconds
Lobby Door Timer	___ seconds	___ seconds
Nudging Timer	___ seconds	___ seconds
Time out of Service Timer	___ None ___ seconds	___ None ___ seconds
Motor Limit Timer	___ minutes	___ minutes
Valve Limit Timer (Hydro only)	___ minutes	___ minutes
MGR Output Timer (Traction only)	___ minutes	___ minutes
Door Hold Input Timer	___ seconds	___ seconds
Parking Delay Timer	___ minutes	___ minutes
Fan/Light Output Timer	___ minutes	___ minutes
Hospital Emerg. Timer	___ minutes	___ minutes
Door Open Protection Timer	___ seconds	___ seconds
CTL Door Cycle Timer	___ seconds	___ seconds
Door Buzzer Timer	___ seconds	___ seconds
Opn/Cls Interlock Timer	___ None ___ seconds	___ None ___ seconds
Fire PH1. Reclose Timer	___ None ___ seconds	___ None ___ seconds
Sync. Op. Delay Timer (Hydro only)	___ None ___ seconds	___ None ___ seconds
<b>GONGS/LANTERNS</b>		
Mounted in hall or car?	___ Hall ___ Car	___ Hall ___ Car
Double strike on Down?	___ Yes ___ No	___ Yes ___ No
PFG Enable Button?	___ Yes ___ No	___ Yes ___ No
Egress Floor Arrival Gong?	___ No Main Egress Floor = ___	___ No Main Egress Floor = ___
Car lantern Door Fully Open?	___ Yes ___ No	___ Yes ___ No

Program Mode (F1) Parameter Settings Record		
OPTIONS	CURRENT VALUES	NEW VALUES
<b>SPARE INPUTS</b>		
(SP1) SPIN1 on HC-CTL used for:		
(SP2) SPIN2 on HC-CTL used for:		
(SP3) SPIN3 on HC-CTL used for:		
(SP4) SPIN4 on HC-CTL used for:		
(SP5) SPIN5 on HC-CTL used for:		
(SP6) SPIN6 on HC-CTL used for:		
(SP7) SPIN7 on HC-CTL used for:		
(SP8) SPIN8 on HC-CTL used for:		
(SP9) SPIN9 on HC-CTL used for:		
(SP10) SPIN10 on HC-CTL used for:		
(SP11) IO 1 on UIO 32 used for:		
(SP12) IO 2 on UIO 32 used for:		
(SP13) IO 3 on UIO 32 used for:		
(SP14) IO 4 on UIO 32 used for:		
(SP15) IO 5 on UIO 32 used for:		
(SP16) IO 6 on UIO 32 used for:		
(SP17) IO 7 on UIO 32 used for:		
(SP18) IO 8 on UIO 32 used for:		
(SP19) IO 1 on UIO 33 used for:		
(SP20) IO 2 on UIO 33 used for:		
(SP21) IO 3 on UIO 33 used for:		
(SP22) IO 4 on UIO 33 used for:		
(SP23) IO 5 on UIO 33 used for:		
(SP24) IO 6 on UIO 33 used for:		
(SP25) IO 7 on UIO 33 used for:		
(SP26) IO 8 on UIO 33 used for:		
(SP27) IO 1 on UIO 34 used for:		
(SP28) IO 2 on UIO 34 used for:		
(SP29) IO 3 on UIO 34 used for:		
(SP30) IO 4 on UIO 34 used for:		
(SP31) IO 5 on UIO 34 used for:		
(SP32) IO 6 on UIO 34 used for:		
(SP33) IO 7 on UIO 34 used for:		
(SP34) IO 8 on UIO 34 used for:		
(SP35) IO 1 on UIO 35 used for:		
(SP36) IO 2 on UIO 35 used for:		
(SP37) IO 3 on UIO 35 used for:		
(SP38) IO 4 on UIO 35 used for:		
(SP39) IO 5 on UIO 35 used for:		
(SP40) IO 6 on UIO 35 used for:		
(SP41) IO 7 on UIO 35 used for:		
(SP42) IO 8 on UIO 35 used for:		
(SP43) IO 1 on UIO 36 used for:		
(SP44) IO 2 on UIO 36 used for:		
(SP45) IO 3 on UIO 36 used for:		
(SP46) IO 4 on UIO 36 used for:		
(SP47) IO 5 on UIO 36 used for:		
(SP48) IO 6 on UIO 36 used for:		
(SP49) IO 7 on UIO 36 used for:		
(SP50) IO 8 on UIO 36 used for:		
I10 on CPI F used for:		
I11 on CPI F used for:		
I12 on CPI F used for:		
I13 on CPI F used for:		
I14 on CPI F used for:		



**Program Mode (F1) Parameter Settings Record**

OPTIONS	CURRENT VALUES	NEW VALUES
I15 on CPI F used for:		
I16 on CPI F used for:		
I10 on CPI R used for:		
I11 on CPI R used for:		
I12 on CPI R used for:		
I13 on CPI R used for:		
I14 on CPI R used for:		
I15 on CPI R used for:		
I16 on CPI R used for:		
I1 on CPI FX used for:		
I2 on CPI FX used for:		
I3 on CPI FX used for:		
I4 on CPI FX used for:		
I5 on CPI FX used for:		
I6 on CPI FX used for:		
I7 on CPI FX used for:		
<b>SPARE OUTPUTS</b>		
(OUT1) SPOUT1 on CTL used for:		
(OUT2) SPOUT2 on CTL used for:		
(OUT3) SPOUT3 on CTL used for:		
(OUT4) SPOUT4 on CTL used for:		
(OUT5) IO 9 on UIO 32 used for:		
(OUT6) IO 10 on UIO 32 used for:		
(OUT7) IO 11 on UIO 32 used for:		
(OUT8) IO 12 on UIO 32 used for:		
(OUT9) IO 13 on UIO 32 used for:		
(OUT10) IO 14 on UIO 32 used for:		
(OUT11) IO 15 on UIO 32 used for:		
(OUT12) IO 16 on UIO 32 used for:		
(OUT13) IO 9 on UIO 33 used for:		
(OUT14) IO 10 on UIO 33 used for:		
(OUT15) IO 11 on UIO 33 used for:		
(OUT16) IO 12 on UIO 33 used for:		
(OUT17) IO 13 on UIO 33 used for:		
(OUT18) IO 14 on UIO 33 used for:		
(OUT19) IO 15 on UIO 33 used for:		
(OUT20) IO 16 on UIO 33 used for:		
(OUT21) IO 9 on UIO 34 used for:		
(OUT22) IO 10 on UIO 34 used for:		
(OUT23) IO 11 on UIO 34 used for:		
(OUT24) IO 12 on UIO 34 used for:		
(OUT25) IO 13 on UIO 34 used for:		
(OUT26) IO 14 on UIO 34 used for:		
(OUT27) IO 15 on UIO 34 used for:		
(OUT28) IO 16 on UIO 34 used for:		
(OUT29) IO 9 on UIO 35 used for:		
(OUT30) IO 10 on UIO 35 used for:		
(OUT31) IO 11 on UIO 35 used for:		
(OUT32) IO 12 on UIO 35 used for:		
(OUT33) IO 13 on UIO 35 used for:		
(OUT34) IO 14 on UIO 35 used for:		
(OUT35) IO 15 on UIO 35 used for:		
(OUT36) IO 16 on UIO 35 used for:		
(OUT37) IO 9 on UIO 36 used for:		
(OUT38) IO 10 on UIO 36 used for:		
(OUT39) IO 11 on UIO 36 used for:		

## Motion 2000 Parameter Settings Record

<b>Program Mode (F1) Parameter Settings Record</b>		
<b>OPTIONS</b>	<b>CURRENT VALUES</b>	<b>NEW VALUES</b>
(OUT40) IO 12 on UIO 36 used for:		
(OUT41) IO 13 on UIO 36 used for:		
(OUT42) IO 14 on UIO 36 used for:		
(OUT43) IO 15 on UIO 36 used for:		
(OUT44) IO 16 on UIO 36 used for:		
O10 on CPI F used for:		
O11 on CPI F used for:		
O12 on CPI F used for:		
O13 on CPI F used for:		
O14 on CPI F used for:		
O15 on CPI F used for:		
O16 on CPI F used for:		
O10 on CPI R used for:		
O11 on CPI R used for:		
O12 on CPI R used for:		
O13 on CPI R used for:		
O14 on CPI R used for:		
O15 on CPI R used for:		
O16 on CPI R used for:		
O1 on CPI FX used for:		
O2 on CPI FX used for:		
O3 on CPI FX used for:		
O4 on CPI FX used for:		
O5 on CPI FX used for:		
O6 on CPI FX used for:		
O7 on CPI FX used for:		
<b>EXTRA FEATURES</b>		
PI Output Type:	__ 1 wire per floor __ Binary 1 __ Binary 0 __ Gray code 1 __ Gray code 0	__ 1 wire per floor __ Binary 1 __ Binary 0 __ Gray code 1 __ Gray code 0
Floor Encoding Inputs? (Hydro only)	__ Yes __ No	__ Yes __ No
Encode All Floors? (Hydro only)	__ Yes __ No	__ Yes __ No
Intermediate Speed? (Traction only)	__ Yes __ No	__ Yes __ No
Emergency Power Operation?	__ No Emergency Power Return Floor = __	__ No Emergency Power Return Floor = __
Light Load Weighing?	__ No Light Load Car Call Limit = __	__ No Light Load Car Call Limit = __
Photo Eye Anti-Nuisance?	__ No Consec Stops w/o PHE Limit = __	__ No Consec Stops w/o PHE Limit = __
MG Shutdown Operation (Traction only)	__ MGS Return Landing	__ MGS Return Landing
CC Card Reader Security?	__ Yes __ No	__ Yes __ No
WPIA Landing?	__ Landing __ Front __ Rear __ Both	__ Landing __ Front __ Rear __ Both
WPIB Landing?	__ Landing __ Front __ Rear __ Both	__ Landing __ Front __ Rear __ Both
WPIC Landing?	__ Landing __ Front __ Rear __ Both	__ Landing __ Front __ Rear __ Both
WPID Landing?	__ Landing __ Front __ Rear __ Both	__ Landing __ Front __ Rear __ Both
WPIE Landing?	__ Landing __ Front __ Rear __ Both	__ Landing __ Front __ Rear __ Both
WPIF Landing?	__ Landing __ Front __ Rear __ Both	__ Landing __ Front __ Rear __ Both
WPIG Landing?	__ Landing __ Front __ Rear __ Both	__ Landing __ Front __ Rear __ Both
WPIH Landing?	__ Landing __ Front __ Rear __ Both	__ Landing __ Front __ Rear __ Both
Allow Car Calls on WP Sec?	__ Yes __ No	__ Yes __ No
Cancel Both Hall (U/D) Calls?	__ Yes __ No	__ Yes __ No
Retain Calls On CTL/CTF?	__ Yes __ No	__ Yes __ No
Automatic Floor Stop Option?	__ No Floor # for Car to Stop at: ____	__ No Floor # for Car to Stop at: ____
Car Call Cancel with Direction Reversal?	__ Yes __ No	__ Yes __ No
Cancel Car Calls Behind Car?	__ Yes __ No	__ Yes __ No
CE Electronics Board?	__ Rev 1 __ Rev 2	__ Rev 1 __ Rev 2
Massachusetts EMS Service?	__ No EMS Service Floor #: ____	__ No EMS Service Floor #: ____
Master Software Key	__ Activated __ Deactivated __ Enabled	__ Activated __ Deactivated __ Enabled
PI Turned off if No Demand?	__ Yes __ No	__ Yes __ No
Hospital Emerg. Operation (This car)	__ Yes __ No	__ Yes __ No



**Program Mode (F1) Parameter Settings Record**

OPTIONS	CURRENT VALUES	NEW VALUES
Hospital Calls Frnt/Flr (This car)?	1 2 3 4 5 6 7 8 10 11 12 13 14 15 16 17 18 19 20 21 22 23 24 25 26 27 28 29 30 31 32	1 2 3 4 5 6 7 8 10 11 12 13 14 15 16 17 18 19 20 21 22 23 24 25 26 27 28 29 30 31 32
Hospital Calls Rear/Flr (This car)?	1 2 3 4 5 6 7 8 10 11 12 13 14 15 16 17 18 19 20 21 22 23 24 25 26 27 28 29 30 31 32	1 2 3 4 5 6 7 8 10 11 12 13 14 15 16 17 18 19 20 21 22 23 24 25 26 27 28 29 30 31 32
Hospital Emerg. Operation (Other car)	___ Yes ___ No	___ Yes ___ No
Other Car Hospital Calls Frnt/Flr?	1 2 3 4 5 6 7 8 10 11 12 13 14 15 16 17 18 19 20 21 22 23 24 25 26 27 28 29 30 31 32	1 2 3 4 5 6 7 8 10 11 12 13 14 15 16 17 18 19 20 21 22 23 24 25 26 27 28 29 30 31 32
Other Car Hospital Calls Rear/Flr?	1 2 3 4 5 6 7 8 10 11 12 13 14 15 16 17 18 19 20 21 22 23 24 25 26 27 28 29 30 31 32	1 2 3 4 5 6 7 8 10 11 12 13 14 15 16 17 18 19 20 21 22 23 24 25 26 27 28 29 30 31 32
Fire Bypasses Hospital?	___ Yes ___ No	___ Yes ___ No
High Speed Delay After Run?	___ Yes ___ No	___ Yes ___ No
Single Speed AC Option? (Traction only)	___ Yes ___ No	___ Yes ___ No
Sabbath Operation?	___ Yes ___ No	___ Yes ___ No
Sabbath Up Calls Front Floor?	1 2 3 4 5 6 7 8 10 11 12 13 14 15 16 17 18 19 20 21 22 23 24 25 26 27 28 29 30 31	1 2 3 4 5 6 7 8 10 11 12 13 14 15 16 17 18 19 20 21 22 23 24 25 26 27 28 29 30 31
Sabbath Up Calls Rear Floor?	1 2 3 4 5 6 7 8 10 11 12 13 14 15 16 17 18 19 20 21 22 23 24 25 26 27 28 29 30 31	1 2 3 4 5 6 7 8 10 11 12 13 14 15 16 17 18 19 20 21 22 23 24 25 26 27 28 29 30 31
Sabbath Down Calls Front Floor?	2 3 4 5 6 7 8 10 11 12 13 14 15 16 17 18 19 20 21 22 23 24 25 26 27 28 29 30 31 32	2 3 4 5 6 7 8 10 11 12 13 14 15 16 17 18 19 20 21 22 23 24 25 26 27 28 29 30 31 32
Sabbath Down Calls Rear Floor?	2 3 4 5 6 7 8 10 11 12 13 14 15 16 17 18 19 20 21 22 23 24 25 26 27 28 29 30 31 32	2 3 4 5 6 7 8 10 11 12 13 14 15 16 17 18 19 20 21 22 23 24 25 26 27 28 29 30 31 32
Intermediate Speed between Floors?	1 2 3 4 5 6 7 8 10 11 12 13 14 15 16 17 18 19 20 21 22 23 24 25 26 27 28 29 30 31 32	1 2 3 4 5 6 7 8 10 11 12 13 14 15 16 17 18 19 20 21 22 23 24 25 26 27 28 29 30 31 32
Leveling Sensors	___ Enabled ___ Disabled	___ Enabled ___ Disabled
KCE	___ Enabled ___ Disabled	___ Enabled ___ Disabled
Analog Load Weigher?	___ None ___ MCE ___ K-Tech	___ None ___ MCE ___ K-Tech
Ind. Bypass Security?	___ Yes ___ No	___ Yes ___ No
Ats. Bypass Security?	___ Yes ___ No	___ Yes ___ No
Car to Floor Return Floor	___ Floor	___ Floor
Scrolling Speed	___ Slow ___ Normal ___ Fast	___ Slow ___ Normal ___ Fast
Low Oil Switch Contact (Hydro only)	___ N.O. ___ N.C.	___ N.O. ___ N.C.
OFRP Between Flrs	___ Floor ___ Floor	___ Floor ___ Floor
Enable Front DOB on Security?	___ Yes ___ No	___ Yes ___ No
Enable Rear DOB on Security?	___ Yes ___ No	___ Yes ___ No
Flr Count Below Flood Level?	___	___
Disable Top Flrs on PITFLD?	___ Yes ___ No	___ Yes ___ No
Earthquake Operation? (Traction only)	___ Yes ___ No	___ Yes ___ No
Calif/ANSI Earthquake Operation	___ ANSI ___ Calif. (Traction only)	___ ANSI ___ Calif. (Traction only)
Counterweighted Drum Machine	___ Yes ___ No (Traction only)	___ Yes ___ No (Traction only)
Earthquake Shutdown at a Landing	___ Yes ___ No (Traction only)	___ Yes ___ No (Traction only)
Correction Away from Counter Weight	___ Yes ___ No (Traction only)	___ Yes ___ No (Traction only)
Earthquake Shutdown PH1 Fire Service	___ Yes ___ No (Traction only)	___ Yes ___ No (Traction only)
Earthquake Shutdown PH2 Fire/Hospital	___ Yes ___ No (Traction only)	___ Yes ___ No (Traction only)
<b>ADDITIONAL CAR OPTIONS (Hydro only) (was ASME A17.1 - 2000 Features)</b>		
Hoistway Access?	___ Yes ___ No	___ Yes ___ No
Top Access?	___ Front ___ Rear	___ Front ___ Rear
Bottom Access?	___ Front ___ Rear	___ Front ___ Rear
Number of Motor Starters	___1 ___2 ___3	___1 ___2 ___3
Minimum Number of Motors	___1 ___2 ___3	___1 ___2 ___3
Soft-Stop Timer	___ Seconds	___ Seconds
Starter #1 Type	___ Wye-Delta ___ Across the Line ___ Solid State ___ None	___ Wye-Delta ___ Across the Line ___ Solid State ___ None
Y-D Transfer Timer	___ Seconds ___ N/A	___ Seconds ___ N/A
Y-D Open Transn. Timer	___ mSeconds ___ N/A	___ mSeconds ___ N/A
Up To Speed Timer	___ Seconds ___ N/A	___ Seconds ___ N/A
M Contactor Installed?	___ Yes ___ No	___ Yes ___ No
Starter #2 Type	___ Wye-Delta ___ Across the Line ___ Solid State ___ None	___ Wye-Delta ___ Across the Line ___ Solid State ___ None
Y-D Transfer Timer	___ Seconds ___ N/A	___ Seconds ___ N/A

## Motion 2000 Parameter Settings Record

<b>Program Mode (F1) Parameter Settings Record</b>		
<b>OPTIONS</b>	<b>CURRENT VALUES</b>	<b>NEW VALUES</b>
Y-D Open Transn. Timer	___ mSeconds ___ N/A	___ mSeconds ___ N/A
Up To Speed Timer	___ Seconds ___ N/A	___ Seconds ___ N/A
M Contactor Installed?	___ Yes ___ No	___ Yes ___ No
Starter #3 Type	___ Wye-Delta ___ Across the Line ___ Solid State ___ None	___ Wye-Delta ___ Across the Line ___ Solid State ___ None
Y-D Transfer Timer	___ Seconds ___ N/A	___ Seconds ___ N/A
Y-D Open Transn. Timer	___ mSeconds ___ N/A	___ mSeconds ___ N/A
Up To Speed Timer	___ Seconds ___ N/A	___ Seconds ___ N/A
M Contactor Installed?	___ Yes ___ No	___ Yes ___ No
Starter Configuration	___ Sequential ___ Simultaneous ___ N/A	___ Sequential ___ Simultaneous ___ N/A
Valve Type	___ Standard ___ Pilot Relays ___ TKE ___ Dover	___ Standard ___ Pilot Relays ___ TKE ___ Dover
Speed > 150 FPM?	___ Yes ___ No	___ Yes ___ No
<b>ADDITIONAL CAR OPTIONS (Traction only) (was ASME A17.1 - 2000 Features)</b>		
ETS Switches Required?	___ Yes ___ No	___ Yes ___ No
Hoistway Access?	___ Yes ___ No	___ Yes ___ No
Top Access?	___ Front ___ Rear	___ Front ___ Rear
Bottom Access?	___ Front ___ Rear	___ Front ___ Rear
<b>ADDITIONAL CAR OPTIONS (Hydro &amp; Traction) (was ASME A17.1 - 2000 Features)</b>		
Door Position Monitor	___ None ___ Front ___ Rear ___ Both	___ None ___ Front ___ Rear ___ Both
Front Door Close Limit?	___ None ___ DCL ___ GS+DCAB	___ None ___ DCL ___ GS+DCAB
Rear Door Close Limit?	___ None ___ DCLR ___ GS+DCABR	___ None ___ DCLR ___ GS+DCABR
<b>TIMED FEATURES</b>		
Sync Op. Days: (Hydro only)	__ Evdy __ Mo __ Tu __ We __ Th __ Fr __ Sa __ Su	__ Evdy __ Mo __ Tu __ We __ Th __ Fr __ Sa __ S
Sync Starting Time	___ 24 Hr format/ 30 min increments	___ 24 Hr format/ 30 min increments
Motion 2000/4000 Version 00.08.0047		

7

## Elevator Security Information and Operation

Building name:

Building location:

Security activation:	Key switch	Mon: from	to
	or	Tue: from	to
Time clock		Wed: from	to
		Thu: from	to
		Fri: from	to
		Sat: from	to
		Sun: from	to

**Instructions:** To gain access to secured floors, follow the steps below while in the elevator car. The steps may be taken while the car is moving or standing still. Requests for a car from a hallway or corridor are answered without restriction.

1. While in the car, press the button for the desired floor. If the destination floor is secured, the button for that floor will flash on/off.  
If the button for that floor stays solidly illuminated, that floor is unsecured.
2. While the destination floor button is flashing, enter the security code for that floor within 10 seconds. Enter the security code by pressing the corresponding buttons on the panel.  
If the code was entered correctly and within the required time limit, the car will immediately go to that floor. If the code was not entered within the 10-second time limit or was entered incorrectly, the destination floor button light will turn off after 10 seconds and the entire sequence must be repeated.

If a mistake is made while entering the security code, simply wait until the destination floor button light stops flashing and then start the entire sequence again.



### Security Codes

Maintain a record of the security codes by noting the floor name as found in the elevator cab and each floor's code. Any floor with a security code is a secured floor.

1. Floor	security code	=	_____
2. Floor	security code	=	_____
3. Floor	security code	=	_____
4. Floor	security code	=	_____
5. Floor	security code	=	_____
6. Floor	security code	=	_____
7. Floor	security code	=	_____
8. Floor	security code	=	_____
9. Floor	security code	=	_____
10. Floor	security code	=	_____
11. Floor	security code	=	_____
12. Floor	security code	=	_____
13. Floor	security code	=	_____
14. Floor	security code	=	_____
15. Floor	security code	=	_____
16. Floor	security code	=	_____
17. Floor	security code	=	_____
18. Floor	security code	=	_____
19. Floor	security code	=	_____
20. Floor	security code	=	_____
21. Floor	security code	=	_____
22. Floor	security code	=	_____
23. Floor	security code	=	_____
24. Floor	security code	=	_____
25. Floor	security code	=	_____
26. Floor	security code	=	_____
27. Floor	security code	=	_____
28. Floor	security code	=	_____
29. Floor	security code	=	_____
30. Floor	security code	=	_____
31. Floor	security code	=	_____
32. Floor	security code	=	_____

# LS-QUTE Landing System Assembly Drawings



If a sensor or the HC-IPLS board is replaced, make sure the **orientation of the HC-IPLS** board is correct. Use the chassis ground and the LEDs shown in the figure below for an orientation reference.

Figure 7.1 LS-QUTE Enclosure Assembly

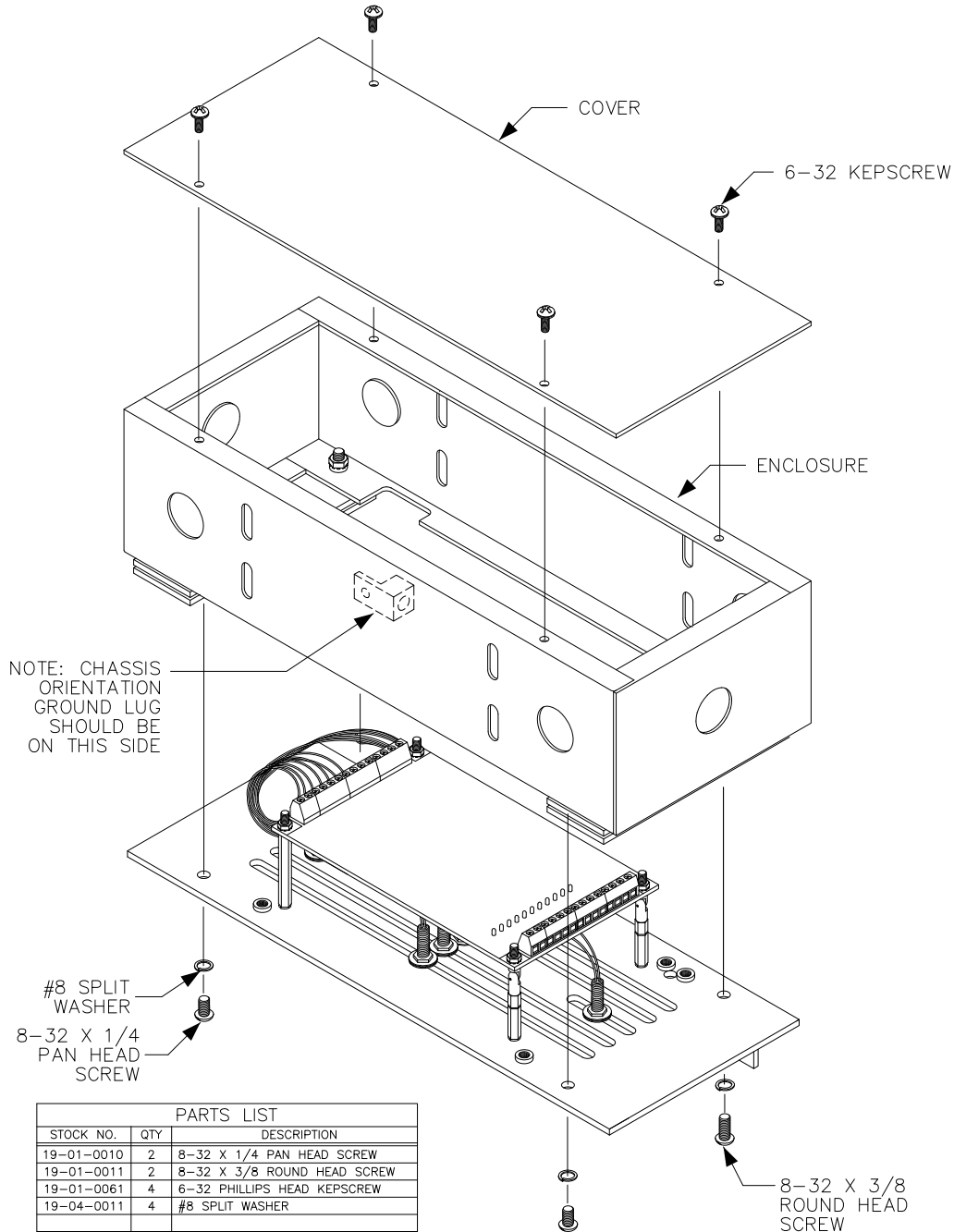

D/N: 1207 R 2

**Figure 7.2 LS-QUTE Wiring Diagram**

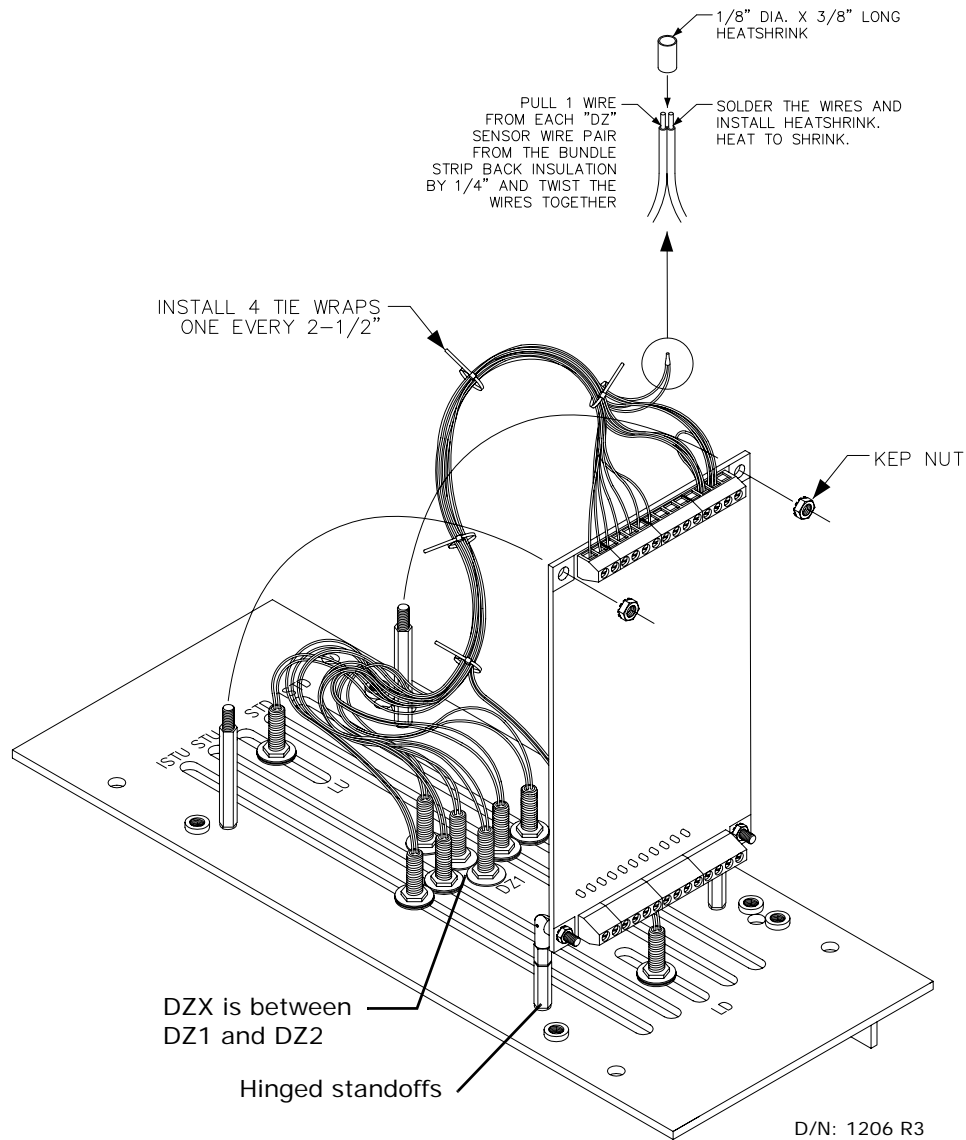

SENSOR	HC-IPLS BOARD TERMINALS	
DZ1	DZ2 SENSOR	S18
DZX	SDZX	S18
DZ2	DZ1 SENSOR	S27
DZF	SDZF	S18
DZR	SDZR	S18
LD	SLD	S18
LU	SLU	S18
STD	STD	S2
STU	STU	S2
ISTD	ISTD	S2
ISTU	ISTU	S2
One 2 inch jumper	S18	S2



# Index

## Numerics

2 BUS IS LOW message 6-4  
2 or 2xx Bus 6-3  
2AB Spare input 5-30  
2FS BUS IS LOW message 6-4  
2HA BUS IS LOW message 6-4  
2MV BUS IS LOW message 6-4  
2S INPUT FAILURE message 6-4  
702 - 7xx, Front Down Hall Call Indicator Outputs 5-40  
702R - 7xxR, Rear Down Hall Call Indicator Outputs 5-40  
801 - 8xx, Front Up Hall Call Indicator Outputs 5-40  
801R - 8xxR, Rear Up Hall Call Indicator Outputs 5-40  
900, Car Call Cancellation Output 5-40

## A

ABD INPUT FAILURE message 6-4  
ABI, Alarm Bell Input 5-30  
absolute floor encoding 4-2  
ABU INPUT FAILURE message 6-4  
ABZ, Attendant Service Buzzer Output 5-40  
ACCESS ENABLED message 6-4  
ACI 5-30  
ALI 5-30  
ALLOW CAR CALLS ON WP SEC. option 5-49  
ALT. PARKING FLOOR option 5-19  
Alternate Lobby Input 5-30  
ALV, Alive Input 5-30  
ALV, Other car alive output flag 5-9  
Analog Load Weigher Learn Function 5-63  
ANALOG LOAD WEIGHER? option 5-52  
API, Alternate Parking Input 5-30  
API, Alternate Parking Input flag 5-9  
ARST, Alarm Reset input 5-30  
ASME A17.1 2000 Features Menu Options 5-53–5-54  
ASME A17.1-2000 compliant 1-3  
ASME A17.1A 2005 ADDENDA? option 5-21  
ATD INPUT FAILURE message 6-4  
ATS, Attendant Service Input 5-30  
ATS. BYPASS SECURITY? option 5-52  
Attendant Service Operation 1-14  
Attendant Service Operation message 6-5  
ATU INPUT FAILURE message 6-5  
AUTO, Emergency power auto output flag 5-9  
AUTO, Emergency Power Auto Selection Input 5-30  
AUTOMATIC FLOOR STOP OPTION? option 5-49  
Automatic Mode Fault Bypass 5-65  
Auxiliary starter timeout message 6-5  
AXR, Auxiliary Reset Input 5-30

## B

BAB Spare input 5-30  
Basic Features Menu Options 5-17–5-19  
Basic Security 5-59  
    programming or changing the Security codes 5-60  
Battery replacement 6-53  
BFD, Bottom floor demand flag 5-9  
BMS-LINK 1-20

Board identification 1-4  
Board Software Versions 5-73  
Both USD and DSD are Open message 6-34  
BOTTOM ACCESS SW. FAILURE message 6-5  
BOTTOM ACCESS? (F/R) option 5-53  
Bottom Floor Demand message 6-5  
BOTTOM FLOOR OR TOP FLOOR DEMAND message 5-12  
Bottom Floor or Top Floor Demand message 6-5  
BOTTOM, Bottom landing output 5-40  
BSI, Building Security Input 5-30  
Bus Fuse Blown (2C) message 6-6  
Bus Fuse Blown (2H) message 6-17  
BYPASS STOP SW. ON PHASE 1 option 5-20

## C

CAN Bus termination 6-64  
CANCEL BOTH HALL (U/D) CALLS option 5-49  
CANCEL CAR CALLS BEHIND CAR? option 5-49  
Capture for Test 1-18  
Capture For Test message 6-5  
Car Call Bus is Disconnected message 6-6  
CAR CALL CANCELS DOOR TIME option 5-22  
CAR CALL DOOR TIMER 5-26  
car calls, registering 4-3, 5-67  
Car Controller  
    final adjustments 4-7, 4-8  
    ground wiring 2-8, 2-9  
    installation of 2-7  
    proper grounding 2-9  
    wiring 2-7  
    wiring prints 2-5  
CAR DOOR BYPASS SW. FAILURE message 6-6  
CAR IDENTIFIER option 5-19  
Car in Test Mode message 6-6  
CAR LANTERN DOOR FULLY OPEN option 5-28  
Car Recall 1-17  
Car Safety Device Open message 6-6  
CAR SERVES FRNT/FLR X option 5-18  
CAR SERVES REAR/FLR X? option 5-18  
Car to Floor Function message 6-6  
CAR TO FLOOR RETURN FLOOR option 5-52  
Car to Lobby Operation message 6-6  
CAR TOP INSPECTION message 6-6  
Cartop Communication, verifying 6-64  
Cartop Inspection 1-12  
CC CANCEL W/DIR REVERSAL? option 5-49  
CC CARD READER SECURITY? option 5-49  
CC, Car call flag 5-9  
CCA, Car call above flag 5-9  
CCB, Car call below flag 5-9  
CCC, Car call cancel input flag 5-9  
CCC, Car Calls Cancel Input 5-30  
CCD, Car call disconnect flag 5-9  
CCDE, Car Call Disconnect Enable Output 5-40  
CCH, Car call hold flag 5-9  
CCR, Car call flag (rear) 5-9  
CCT, Car call time flag 5-9

CCT, Car Call Time Flag Output 5-40  
 CCTR, Car call time flag (rear) 5-9  
 CD, Car Done (Emergency Power Return) Output 5-40  
 CD, Car done flag 5-9  
 CE ELECTRONICS INTERFACE? option 5-49  
 CEPR, Completed Emergency Power Return output 5-40  
 CFLT, CSA Fault Output 5-40  
 CGED, Car Gong Enable Down Output 5-40  
 CGEDR, CGED for rear doors Output 5-40  
 CGEU, Car Gong Enable Up Output 5-40  
 CGEUR, CGEU for rear doors Output 5-40  
 CGF, Car Generated Fault Output 5-40  
 CHBPO, Car and Hoistway Bypass Output 5-41  
 CHBPO, Car and Hoistway Door Bypass Output 5-41  
 CNFG, Configuration error flag 5-9  
 CNP, Contactor Proof Input 5-30  
 Computer Internal Memory 5-7, 5-8, 5-9  
 computer security 5-5  
     entering the password 5-5  
 Computer Variable Flags 5-9  
 Configuration Error-change Settings Before Installation message 6-6  
 Connection Set 1-19  
 Connections screen 5-70  
 CONSEC STOPS W/O PHE LIMIT option 5-48  
 CONST. PRESS OP. BYPASS PHE option 5-25  
 Construction operation 3-4  
 Construction operation jumpers 3-4  
 CONT. D.C.B. FOR FIRE PH 1 option 5-24  
 CONT. D.C.B. TO CLOSE DOORS option 5-23  
 Contactor Proofing Redundancy Failure message 6-6  
 Controller System Menu 5-65  
 CONTROLLER TYPE option 5-17  
 CR1 - CRx, Card Reader Front Landing Inputs 5-31  
 CR1R - CRxR, Card Reader Rear Landing Inputs 5-31  
 CRO, Card Reader Override input 5-31  
 CRO1 - CRxx, Car Card Reader Front Landing Outputs 5-41  
 CRO1R - CRxxR, Car Card Reader Rear Landing Outputs 5-41  
 CSB, Car stop switch bypass flag 5-9  
 CSB, Car Stop Switch Bypass Output 5-41  
 CSBR, Car stop switch bypass (rear) flag 5-9  
 CSEO, Code Sequence Enable Output 5-41  
 CSR, Car Selected to Run Output 5-41  
 CTF, Car to floor Input 5-31  
 CTL DOOR OPEN TIMER 5-27  
 CTL, Car to lobby input flag 5-10  
 CTL, Car-to-Lobby Input 5-31  
 CTLDOT, Car to lobby door open timer flag 5-10  
 CTLDOT, Car-to-Lobby Door Open Timer Output 5-41  
 CTLF, Car to lobby function flag 5-10  
 CTST, Capture for Test Input 5-31  
 CTST, Capture for test input flag 5-10  
 Current Load display 5-72

**D**

D.C.B. CANCELS DOOR TIME option 5-23  
 Date and Time, setting 5-68  
 DBC, Door close button input flag 5-10  
 DBCR, Door close button (rear) flag 5-10  
 DBZF, Front Door Buzzer output 5-41  
 DBZR, Rear Door Buzzer Output 5-41  
 DC, Down call flag 5-10  
 DCA, Down call above flag 5-10  
 DCAB INPUT FAILURE message 6-7  
 DCB, Down call below flag 5-10  
 DCC, Door close complete flag 5-10  
 DCCR, Door close complete flag (rear) 5-10  
 DCF, Door close function output flag 5-10  
 DCFR, Door close function output (rear) flag 5-10  
 DCFRX, Rear Door Close Function Auxiliary Output 5-41  
 DCFX, Door Close Function Auxiliary Output 5-41  
 DCL, Door Close Limit Input 5-31  
 DCLC, Doors Closed Contact Input 5-31  
 DCLCR INPUT FAILURE message 6-7  
 DCLCR, Door close contact input (rear) flag 5-10  
 DCLR, Doors Closed Contact Rear input 5-31  
 DCP, Door close power output flag 5-10  
 DCPR, Door close power output (rear) flag 5-10  
 DCPRX, Rear Door Close Power Auxiliary Output 5-41  
 DCPX, Door Close Power Auxiliary Output 5-41  
 DCR, Down call flag (rear) flag 5-10  
 DDF, Double ding function flag 5-10  
 DDP, Down direction preference flag 5-10  
 DEADZ, Dead zone flag 5-10  
 DEDICATED PI BOARD? 5-19  
 default parameter values 5-13  
 Default XPort screen 5-71  
 DEIS, Front Door Enable Inspection Stop Switch Output 5-41  
 DEISR, Rear Door Enable Inspection Stop Switch Output 5-41  
 Device Data screen 5-71  
 DHEND, Door hold end flag 5-10  
 DHEND, Door Hold End Output 5-41  
 DHENDR, Door hold end rear flag 5-10  
 DHLD, Door Hold Input 5-31  
 DHLD, Door hold input flag 5-10  
 DHLDI, Normal door hold input flag 5-10  
 DHLDR, Rear Door Hold Input 5-31  
 DHO, Door hold open flag 5-10  
 DHO, Door Hold Output 5-42  
 DHOR, Door hold open flag (rear) 5-10  
 Diagnostic Mode ??-5-13  
 DIN, Door open inactive flag 5-10  
 DIR. PREFERENCE UNTIL DLK option 5-23  
 DISABLE DPM ON FIRE PH.2? option 5-21  
 DISABLE LOCAL HALL CALLS? option 5-19  
 DISABLE TOP FLRS ON PITFLD option 5-53  
 DISB, Distress Buzzer output 5-42  
 DISL, Distress Light output 5-42  
 DISLX, Auxiliary Distress Light output 5-42  
 dispatching features  
     dispatch load 5-62  
     heavy load (hall call bypass) 5-62  
     light load (anti-nuisance) 5-62  
     overloaded 5-62  
 DISPATCHING OPERATION option  
     Selective Collective 5-17  
     Single Automatic Push button 5-17  
     Single Button Collective 5-17  
 DL INPUT FAILURE message 6-7

DLI, Dispatch Load Input 5-31  
 DLI, Dispatch Load Input flag 5-10  
 DLK, Door lock input flag 5-10  
 DLKS, Door lock store bit flag 5-10  
 DLOB, Door Left Open Bell Output 5-42  
 DLR INPUT FAILURE message 6-7  
 DLS, Door Lock Sensor Input 5-31  
 DLSR, Door Lock Sensor Rear input 5-31  
 DLW, Dispatch load weighing function flag 5-10  
 DMD, Demand down flag 5-10  
 DMU, Demand up flag 5-10  
 DNDO, Down direction output flag 5-10  
 DNENDR, Rear Door Hold End Output 5-41  
 DNI, Down Input (Attendant Service) 5-31  
 DNO, Down output (Attendant Service) 5-42  
 DNS, Down direction sense input flag 5-10  
 DNS, Down Sense output 5-42  
 DO1, DO2, DO4, DO8, DO16, DO32  
     Binary coded P.I. outputs for digital P.I. devices 5-42  
 DOB, Door open button input flag 5-10  
 DOBR, Door open button input (rear) flag 5-10  
 DOC, Door open command flag 5-10  
 DOCR, Door open command (rear) flag 5-10  
 DOF, Door open function output flag 5-10  
 DOFR, Door open function output (rear) flag 5-10  
 DOFRX, Rear Door Open Function Auxiliary Output 5-41  
 DOFX, Door Open Function Auxiliary Output 5-41  
 DOI, Door open intent flag 5-10  
 DOIR, Door open intent flag (rear) 5-10  
 DOL INPUT FAILURE message 6-7  
 DOL, Door Open Limit input 5-31  
 DOL, Door open limit input flag 5-11  
 DOLM, Door open limit memory flag 5-11  
 DOLMR, Door open limit memory (rear) flag 5-11  
 DOLR INPUT FAILURE message 6-7  
 DOLR, Door open limit (rear) flag 5-11  
 DOLR, Door Open Limit Rear input 5-32  
 DOOR BUZZER TIMER 5-27  
 Door Close Protection message 6-8  
 Door Close Protection Timer Elapsed message 6-8  
 DOOR HOLD INPUT TIMER 5-27  
 DOOR OPEN PROTECTION TIMER 5-27  
 Door Operation Menu options ??-5-26  
 DOOR POSITION MONITOR option 5-54  
 Door Position Monitor switch 3-9  
 DOOR TYPE IS? HORIZONTAL / VERTICAL option 5-25  
 Door Zone Sensor Failure - OFF Position message 6-8  
 DOORENAB, Door Enable Output 5-42  
 DOORS TO LATCH DCF? option 5-26  
 DOORS TO LATCH DOF? option 5-26  
 DOORS TO OPEN IF NO DEMAND option 5-25  
 DOORS TO OPEN IF PARKED option 5-24  
 DOORS TO OPEN ON ALT FIRE option 5-24  
 DOORS TO OPEN ON MAIN FIRE option 5-24  
 DOUBLE STRIKE ON DOWN (Gongs) option 5-28  
 DOWN NORMAL LIMIT OPEN message 6-8  
 DOWN TERMINAL LIMIT FAILURE message 6-8  
 DPD, Down previous direction flag 5-11  
 DPM REDUNDANCY FAULT message 6-8  
 DPM, Front Door Position Monitoring input 5-32  
 DPMR REDUNDANCY FAULT message 6-9  
 DPMR, Rear Door Position Monitoring input 5-32  
 DPR, Door protection timer flag 5-11  
 drawing numbers, description of 2-5  
 DRD (UP TO SPEED) FAILED TO ACTIVATE message 6-9  
 DRD INPUT FAILURE message 6-9  
 DSD, Down slow down input flag 5-11  
 DSH, Door shortening flag 5-11  
 DSH, Door Time Shortening Output (intermediate) 5-42  
 DSHT, Door shortening flag 5-11  
 DSHT, Door Time Shortening Front Output (final) 5-42  
 DSHTR, Door shortening (rear) flag 5-11  
 DSHTR, Door Time Shortening Rear Output (final) 5-42  
 DSL 1-19  
 DSTI, Door Stop Input 5-32  
 DSTIC, Door Stop Input Complement 5-32  
 DSTICR, Rear Door Stop Input Complement 5-32  
 DSTIR, Rear Door Stop Input 5-32  
 Duplex dispatcher (D) or a local (L) 5-70  
 Duplexing 5-74  
 DVR 1 IS OFFLINE message 6-9  
 DVR 2 IS OFFLINE message 6-9  
 DVR 2 MSSD FAILED ACTIVE message 6-10  
 DVR 3 IS OFFLINE message 6-10  
 DVR-'n' Auxiliary starter timeout message 6-10  
 DVR-'n' DOWN NORMAL LIMIT OPEN message 6-10  
 DVR-'n' DOWN TERMINAL LIMIT FAILURE message 6-10  
 DVR-'n' DRD (UP TO SPEED) FAILED TO ACTIVATE message 6-10  
 DVR-'n' DRD INPUT FAILURE message 6-11  
 DVR-'n' EXCESSIVE NUMBER OF FAILED START ATTEMPTS message 6-11  
 DVR-'n' M2L INPUT FAILURE message 6-11  
 DVR-'n' MDFE FAILED TO ACTIVATE message 6-11  
 DVR-'n' MDFE FAILED TO DEACTIVATE message 6-11  
 DVR-'n' MDSE FAILED TO ACTIVATE message 6-12  
 DVR-'n' MDSE FAILED TO DEACTIVATE message 6-12  
 DVR-'n' MRD INPUT FAILURE message 6-12  
 DVR-'n' MSSD FAILED TO ACTIVATE message 6-12  
 DVR-'n' MSSD FAILED TO DEACTIVATE message 6-12  
 DVR-'n' MTD FAILED TO ACTIVATE message 6-12  
 DVR-'n' MTD FAILED TO DEACTIVATE message 6-13  
 DVR-'n' MTM FAILED TO ACTIVATE message 6-13  
 DVR-'n' MTM FAILED TO DEACTIVATE message 6-13  
 DVR-'n' MTY FAILED TO ACTIVATE message 6-13  
 DVR-'n' MTY FAILED TO DEACTIVATE message 6-13  
 DVR-'n' MUF E FAILED TO ACTIVATE message 6-13  
 DVR-'n' MUF E FAILED TO DEACTIVATE message 6-14  
 DVR-'n' MUSE FAILED TO ACTIVATE message 6-14  
 DVR-'n' MUSE FAILED TO DEACTIVATE message 6-14  
 DVR-'n' OLM INPUT FAILURE message 6-14  
 DVR-'n' OLM INPUT IS LOW message 6-14  
 DVR-'n' RP SENSOR TRIPPED message 6-15  
 DVR-'n' STARTER FAULT CONTACT OPEN message 6-15  
 DVR-'n' STARTER TYPE ERROR message 6-15  
 DVR-'n' UP NORMAL LIMIT OPEN message 6-15  
 DVR-'n' UP TERMINAL LIMIT FAILURE message 6-15  
 DVR-'n' YRD INPUT FAILURE message 6-15  
 DZ, Door zone input flag 5-11  
 DZORDZ, Front or rear door zone input flag 5-11

DZP, Door zone previous flag 5-11  
DZR, Door zone input (rear) flag 5-11  
DZRX, Door Zone Rear Auxiliary input 5-32  
DZX, Door Zone Auxiliary input 5-32

## E

ECC, Excess car calls flag 5-11  
ECRN, Emergency Car Freeze Input 5-32  
ECRN, Emergency car run flag 5-11  
ECRN, Emergency Power Car Run Output 5-42  
EFG, Egress Floor Gong Output 5-42  
EGRESS FLOOR ARRIVAL GONG option 5-28  
Electrical noise 2-4  
Elevator Shutdown Switch Active message 6-15  
Eligibility Map, setting 5-72  
Emergency Medical Operation 1-15  
Emergency Medical Service message 6-16  
Emergency Power message 6-16  
Emergency Power Operation 1-17  
Emergency Power Operation message 6-16  
EMERGENCY POWER OPERATION? option 5-48  
Emergency Power Return 5-40  
EMERGENCY POWER RETURN FLOOR option 5-48  
EMI/RFI problems 2-4  
EMS SERVICE FLOOR # option 5-49  
EMSB, Emergency Medical Service Buzzer Output 5-43  
EMSC, Emergency Medical Service Car Switch input 5-32  
EMSH, Emergency Medical Service Hall Switch input 5-32  
EMSIC, Emergency Medical Service Car Indicator Output 5-43  
EMSIH, Emergency Medical Service Hall Indicator Output 5-43  
ENABLE FRONT DOB ON SECURITY? option 5-52  
ENABLE REAR DOB ON SECURITY? option 5-52  
ENCODE ALL FLOORS? option 5-48  
Enter Security Code message 6-16  
Environmental Considerations 2-3  
EP1, Emergency Power Phase 1 Output 5-43  
EP2, Emergency Power Phase 2 Output 5-43  
EPI, Emergency Power Input 5-32  
EPI, Emergency power input flag 5-11  
EPR, Emergency power return flag 5-11  
EPR, Emergency Power Return Input 5-32  
EPRUN, Emergency Power Run Input 5-32  
EPRUN, Emergency power run input flag 5-11  
EPSTP, Emergency Power Stop Input 5-32  
EPSTP, Emergency power stop input flag 5-11  
EQH, Earthquake Hydro input 5-32  
error diagnostic display 5-71  
ERU, Emergency Return Unit Input 5-33  
ESS, Elevator Shutdown Input 5-33  
Ethernet 1-19  
EXCESSIVE NUMBER OF FAILED START ATTEMPTS message 6-16  
EXMLT Input Is Activated message 6-16  
EXMLT message 6-16  
EXMLT, External Motor Limit Timer flag 5-11  
EXMLT, External Motor Limit Timer Input 5-33  
EXMLTC, EXMLT Compliment Input 5-33  
External Memory Mode 5-55–5-58

Extra Features Menu Options 5-48–5-53

## F

FAN/LIGHT OUTPUT TIMER 5-27  
FCCC, Fire Phase II Call Cancel Button Input 5-33  
FCCC, Fire phase II car call cancel flag 5-11  
FCHLD, Fire Phase II Door Hold Input 5-33  
FCHLD, Fire phase II hold flag 5-11  
FCOFF, Fire phase II off flag 5-11  
FCOFF, Fire Phase II Switch OFF Position Input 5-33  
FCS, Fire phase II input flag 5-11  
FCSM, Fire service phase II input memory flag 5-11  
FDC, Door fully closed phase II flag 5-11  
FDCR, Door fully closed phase II (rear) flag 5-11  
final adjustments  
    door operator 4-7  
    final adjustments 4-7, 4-8  
    hydraulic valves 4-6  
    registering car calls 4-3, 5-67  
    slowdown and limit switches 4-6  
    test mode operation 4-4  
    testing hall calls 4-8  
    testing options 4-8  
FIR1, Fire Service Phase I output 5-43  
FIRE BYPASSES HOSPITAL option 5-51  
FIRE PH1 RECLOSE TIMER 5-28  
FIRE PHASE 1 ALT. FLOOR option 5-20  
FIRE PHASE 1 MAIN FLOOR option 5-20  
FIRE PHASE I 2ND ALT. FLOOR option 5-20  
Fire Service Alternate message 6-16  
Fire Service Main message 6-16  
Fire Service Menu options 5-20–5-21  
Fire Service Operation 1-16  
FIRE SERVICE OPERATION option 5-20  
Fire Service Phase 1 - Main message 6-16  
Fire Service Phase 1 -Alternate message 6-16  
Fire Service Phase 2 message 6-16  
FIRE SVCE. CODE option 5-20  
Firmware version for all boards 5-72  
Flags/Variables and Their Locations 5-9  
FLASH, Flash Output 5-43  
FLO, Fan/Light Operation Output 5-43  
FLOOR ENCODING INPUTS? option 5-48  
Floor Labels, programming 5-66  
FLR COUNT BELOW FLOOD LEVEL option 5-52  
FRA, Alternate Fire service phase I input flag 5-11  
FRAA, Fire Phase I Alternate (2nd alternate) Input 5-33  
FRAON, Fire Phase I Alternate Switch ON Position Input 5-33  
FRAS, Alternate fire flag 5-11  
FRBYP, Fire phase I bypass input flag 5-11  
FRBYP, Fire Phase I Switch BYPASS Position Input 5-33  
FRC, Fire phase II flag 5-11  
FRC, Fire Service Phase II Output 5-43  
FRCT, True Fire Service Phase II Output 5-43  
FREE, No demand and in service flag 5-11  
FRHTW, Hoistway Fire Sensor input 5-33  
FRM, Fire service phase I flag 5-11  
FRM, Fire Service Phase I Output 5-43  
FRMR, Machine Room Fire Sensor input 5-33



FRON, Fire phase I on input flag 5-11  
 FRON, Fire Phase I Switch ON Position Input 5-33  
 FRON2, Fire Phase 1 Switch ON Position Input 5-33  
 Front DOL & DLK are Both Active message 6-16  
 FRONT DOOR CLOSE LIMITS option 5-54  
 Front Door is Locked but not fully closed message 6-17  
 Front Door Lock Switch Failure message 6-17  
 FRONT DOOR MECH. COUPLED option 5-25  
 Front Door Open Limit Failure message 6-17  
 Front Gate Switch Failure message 6-17  
 FRS, Fire phase I input flag 5-9  
 FRSA, Alternate Fire Service input 5-33  
 FRSM, Main Fire Service input 5-33  
 FRSS, Fire phase I flag 5-9  
 FSA, Fire Service Alternate Output 5-43  
 FSLCX, Fire Service Light C.O.P. Auxiliary Output 5-43  
 FSLX, Fire Service Lobby Light Auxiliary Output 5-43  
 FSM, Fire Service Main Output 5-43  
 FSO, Fire Service On Output 5-43  
 FSVC, True Fire Service Output 5-44  
 FULLY MANUAL DOORS option 5-23  
 FWI, Fire warning indicator output flag 5-9  
 FWIX, Fire Service Buzzer Auxiliary Output 5-44  
 FWL, Fire Warning Light Output 5-44

## G

Gateway screen 5-70  
 GED, Gong enable down output flag 5-9  
 GEDR, Gong enable down output (rear) flag 5-9  
 GEDRX, Gong Enable Down Rear Auxiliary Output 5-44  
 GEDX, Gong Enable Down Auxiliary Output 5-44  
 GEU, Gong enable up output flag 5-9  
 GEUR, Gong enable up output (rear) flag 5-9  
 GEURX, Gong Enable Up Rear Auxiliary Output 5-44  
 GEUX, Gong Enable Up Auxiliary Output 5-44  
 GHT, Gong hold timer flag 5-9  
 GHTR, Gong hold timer flag (rear) 5-9  
 Gongs/Lanterns Menu options 5-28  
 GRAY CODE 5-48  
 Gray Code outputs 5-44  
 Gray Code PI 5-44  
 ground  
   ground test 3-2  
   wiring 2-8, 2-9  
 Grounding 2-8  
 GROUP TO CAR COMMUNICATION LOSS message 6-17  
 GS INPUT FAILURE message 6-17  
 GS, Gate Switch Input 5-33  
 GSR INPUT FAILURE message 6-17  
 GSR, Gate Switch Rear Input 5-34  
 GTDE, Gong timer down enable flag 5-9  
 GTUE, Gong timer up enable flag 5-9

## H

H, High Speed output 5-44  
 H, High speed output flag 5-9  
 Hall and Car Call Buses Disconnected message 6-17  
 Hall Call Bus is disconnected message 6-17  
 HALL CALL DOOR TIMER 5-26  
 HBF, Hall Call Bus Failure input 5-34

HC- DVR Driver Board 1-6  
 HCC, Hall Call Cancel input 5-34  
 HC-CHP CAN Hub and Power Supply Board Quick Reference 6-36  
 HC-CHP, CAN Hub/Power Supply Board 1-5  
 HC-CTL Control Board Quick Reference 6-38  
 HC-CTL Main Control Board 1-7, 1-8  
 HC-DVR Driver Board Quick Reference 6-48  
 HCDX, Hall call disconnect flag 5-9  
 HC-MPU Main Processor Board Quick Reference 6-51  
 HC-MPU Main Processor Unit 5-2  
 HCP, Hall Call Button Pushed Output 5-44  
 HCR, Hall call reject flag 5-9  
 HCR, Hall Call Reject Output 5-44  
 HCR1 - HCRx, Hall Card Reader Front Landing Inputs 5-34  
 HCR1R - HCRxR, Hall Card Reader Rear Landing Inputs 5-34  
 HC-RDR BOARD ON OTHER CAR? option 5-18  
 HC-RDR BOARD ON THIS CAR? option 5-18  
 HC-RDR Rear Door Board Quick Reference 6-54  
 HC-RDR, Rear Door Board 1-8  
 HCRO, Hall Card Reader Override input 5-34  
 HCRO1 - HCRxx, Hall Card Reader Front Landing Outputs 5-44  
 HCRO1R - HCRxxR, Hall Card Reader Rear Landing Outputs 5-44  
 HCT, Hall call door time flag 5-9  
 HCTR, Hall call door time flag (rear) 5-9  
 HC-UIO Universal Input/Output Board 1-6  
 HD, High speed delay flag 5-9  
 HDCB, Front Hall Door Close Button Input 5-34  
 HDCBR, Rear Hall Door Close Button Input 5-34  
 HDNL, High speed down and not leveling output 5-44  
 HDOB, Front Hall Door Open Button Input 5-34  
 HDOBR, Rear Hall Door Open Button Input 5-34  
 HDSC, Heat Detector Shutdown Complete Output 5-44  
 HDSTI, Front Hall Door Stop Input 5-34  
 HDSTIR, Rear Hall Door Stop Input 5-34  
 HEATD, Heat Detector Input 5-34  
 Heavy Load Weigher Condition message 6-18  
 HEO, Hospital Emergency Operation output 5-44  
 HIGH SPEED DELAY AFTER RUN? option 5-51  
 HIGH SPEED INSPECTION option 5-65  
 HLI, Heavy Load Input 5-34  
 HLI, Heavy load input flag 5-10  
 HLW, Heavy load weigher flag 5-10  
 HLW, Heavy Load Weigher Output 5-44  
 HML, Home Landing Input 5-34  
 HML, Home landing input flag 5-10  
 Hoistway Access Inspection 1-13  
 HOISTWAY ACCESS? option 5-53  
 HOISTWAY DOOR BYPASS SW. FAILURE message 6-18  
 Hoistway Safety Device Open message 6-18  
 HONEYWELL FIRE OPERATION option 5-20  
 HOSP, In car hospital emergency input flag 5-10  
 HOSP, In-Car Hospital Service Switch Input 5-35  
 HOSPH2, Hospital emergency phase 2 flag 5-10  
 HOSPH2, Hospital Emergency Phase 2 output 5-44  
 HOSPITAL EMERG. OPERATION? option 5-50  
 HOSPITAL EMERG. TIMER 5-27  
 Hospital Emergency Operation 6-60

- Hospital Operation I/O 6-60
- Hospital Phase 1 Operation message 6-18
- Hospital Phase 2 Operation message 6-18
- Hospital Service message 6-18
- Hospital Service Operation 1-16
- HSEL, Hospital Emergency Select output 5-45
- HSEL, Hospital service select flag 5-10
- HUNL, High speed up and not leveling 5-45
- HWI, Hospital Emergency Select output 5-45
- HYD1-TR0, Hydro/Traction flag 5-10

**I**

- ICPD INPUT FAILURE message 6-18
- ICPU INPUT FAILURE message 6-18
- ICTD INPUT FAILURE message 6-18
- ICTU INPUT FAILURE message 6-18
- IDC connector 6-3
- iMonitor 1-19
- In Car Inspection 1-12
- In Car Stop Switch Activated message 6-19
- IN, Inspection or access input flag 5-10
- INA INPUT FAILURE message 6-18
- INA, INAX Relay Monitoring input 5-35
- IN-CAR INSPECTION message 6-19
- INCF, Independent service car call cancel flag 5-10
- INCP INPUT FAILURE message 6-19
- INCT INPUT FAILURE message 6-19
- IND, Independent service input flag 5-10
- IND. BYPASS SECURITY? option 5-52
- Independent Service message 6-19
- Independent Service Operation 1-14
- Independent Service Operation message 6-19
- INDFRC, Independent Service/Fire Service Phase 2 Output 5-45
- INDO, Independent Service Output 5-45
- INSDN, Inspection Down Input 5-35
- INSP, Inspection output 5-45
- INSPECTION DIRECTION SW. FAILURE message 6-19
- Inspection Mode Fault Bypass 5-65
- Inspection Operation 1-12
- INSPECTION OPERATION message 6-19
- Inspection Operation message 6-19
- INSUP, Inspection Up Input 5-35
- INV. DOOR CLOSE LIMIT option 5-26
- IP address screen 5-70
- IRCOF, Front Infrared Cutout input 5-35
- IRCOR, Rear Infrared Cutout input 5-35
- iReport 1-19
- iReport screen 5-71
- ISR, In service and ready flag 5-10
- ISRT, In Service and Running Output 5-45
- ISRT, In service truly flag 5-10
- ISV, In service flag 5-10
- ISV, In Service Output 5-45
- ISVF, Flasing In-Service output 5-45
- IUL, In Use Light Output 5-45

**J**

- Jumper 6-3
- Jumpers for Construction operation 3-4

**K**

- KCE ENABLE / DISABLE option 5-52

**L**

- landing system
  - installation of 3-9
  - installation of magnets 3-9
- Landing System Interface Board 6-67
- Landing System Redundancy Failure message 6-19
- LATCH FLASHING FIRE HAT? option 5-21
- LCD display 5-7, 5-14, 5-15
- LD, Level down input flag 5-10
- LEAVE DOORS OPEN ON CTL option 5-24
- LEAVE DOORS OPEN ON EPI option 5-25
- LEAVE DOORS OPEN ON PTI/ESS option 5-23
- Leveling Down message 6-19
- Leveling Input is absent message 6-20
- LEVELING SENSOR ENABLED/DISABLED option 5-52
- Leveling Sensor Failed - OFF Position message 6-20
- Leveling Sensor Failed - ON Position message 6-20
- Leveling Sensor Failure message 6-20
- Leveling up message 6-20
- LFP, Lower parking floor flag 5-10
- LIGHT LOAD CAR CALL LIMIT option 5-48
- Light Load Weigher Condition message 6-20
- LIGHT LOAD WEIGHING? option 5-48
- limit switches
  - installation of 3-9
- limit switches, installation of 3-9
- LIMITED DOOR RE-OPEN OPTION option 5-24
- LLI, Light Load Input 5-35
- LLI, Light load input flag 5-10
- LLW, Light Load Weigher Output 5-45
- LLW, Light load weighing function input flag 5-10
- load weighing system
  - DLW (Dispatch load weigher threshold) 5-62
  - HLW (Heavy load weigher threshold) 5-62
  - LLW (Light load weigher threshold) 5-62
  - OLW (Overloaded car threshold) 5-62
  - setting load thresholds 5-62
- LOBBY DOOR TIMER 5-26
- LOBBY FLOOR option 5-19
- LOS, Low Oil Switch input 5-35
- Loss of door lock out of door zone message 6-20
- LOT, Lobby door time flag 5-10
- LOTR, Lobby door time (rear) flag 5-10
- LOW OIL SWITCH CONTACT (N.O. / N.C.) option 5-52
- Low Oil Switch Input is Activated message 6-20
- Low voltage signal wiring 2-10
- LOW VOLTATGE FIRE SENSORS? option 5-21
- LS-QUTE Landing System 1-9
  - assembly drawing 7-13
  - installation of 3-8, 3-9
  - wiring diagram 7-13
- LSR, Landing System Redundancy Input 5-35

LS-STAN Landing System 1-10  
LU, Level up input flag 5-10  
LWB, Load Weigher Bypass input 5-35  
LWCE, Load weighing change enable flag 5-10

## M

M CONTACTOR INSTALLED? option 5-54  
M2L INPUT FAILURE message 6-21  
MABB INPUT FAILURE message 6-21  
MABBR INPUT FAILURE message 6-21  
MABGF INPUT FAILURE message 6-21  
MABGR INPUT FAILURE message 6-21  
MABT INPUT FAILURE message 6-21  
MABTR INPUT FAILURE message 6-22  
Machine Room Inspection 1-13  
MACHINE ROOM INSPECTION message 6-22  
MASS 524 CMR FIRE CODE? option 5-21  
MASSACHUSETTS EMS SERVICE? option 5-49  
MASTER SOFTWARE KEY option 5-50  
MBAB INPUT FAILURE message 6-22  
MBABR INPUT FAILURE message 6-22  
MC-CPI board 6-62  
MC-CPI CAN data viewing 5-69  
MC-LSI 6-67  
MC-MPU Main Computer Board  
    setting parameters to default values 5-13  
MC-MPU Main Processing Unit Board 1-5  
MC-PCA Main Computer Board 5-2  
MCSB INPUT FAILURE message 6-22  
MDFE FAILED TO ACTIVATE message 6-22  
MDFE FAILED TO DEACTIVATE message 6-22  
MDFE INPUT IS LOW message 6-23  
MDSE FAILED TO ACTIVATE message 6-23  
MDSE FAILED TO DEACTIVATE message 6-23  
MDSE INPUT IS LOW message 6-23  
MDZLV INPUT FAILURE message 6-23  
MECHANICAL SAFETY EDGE option 5-23  
Messages and Floor Labels, programming 5-66  
MGB INPUT FAILURE message 6-23  
MGBR INPUT FAILURE message 6-23  
MGS 5-36  
MGS INPUT FAILURE message 6-24  
MGSR INPUT FAILURE message 6-24  
MHDB INPUT FAILURE message 6-24  
MHDBR INPUT FAILURE message 6-24  
MIN. NUMBER OF MOTORS (1-3) option 5-53  
MISV, Mechanically In Service Output 5-45  
MLT, Motor Limit Timer Elapsed Output 5-45  
MLT, Motor limit timer flag 5-10  
MLTDO, Motor limit timer door open flag 5-10  
MLTP, Motor Limit Timer Elapsed Output 5-45  
MLTP, Motor limit timer pilot flag 5-10  
MNO, Manual Override input 5-35  
MOMENT. D.C.B TO CLOSE DOORS? option 5-25  
MOMENT. D.O.B. DOOR OPENING option 5-24  
Monitored type screen 5-70  
Monitoring and Control Options  
    BMS-Link 1-20  
    iMonitor 1-19  
    iReport 1-19

MOTOR LIMIT TIMER 5-27  
Motor Limit Timer (anti-stall) Elapsed message 6-24  
Motor Limit Timer message 6-24  
MOUNTED IN HALL OR CAR (Gongs) option 5-28  
MPI SPA IS OFF LINE message 6-25  
MPI SPB IS OFF LINE message 6-25  
MPI SPC IS OFF LINE message 6-25  
MRD INPUT FAILURE message 6-25  
MSAFL1 INPUT FAILURE message 6-25  
MSAFS1 INPUT FAILURE message 6-25  
MSSD FAILED ACTIVE message 6-25  
MSSD FAILED TO ACTIVATE message 6-26  
MSSD FAILED TO DEACTIVATE message 6-26  
MTAB INPUT FAILURE message 6-26  
MTABR INPUT FAILURE message 6-26  
MTD FAILED TO ACTIVATE message 6-26  
MTD FAILED TO DEACTIVATE message 6-26  
MTD INPUT FAILURE message 6-26  
MTM FAILED TO ACTIVATE message 6-27  
MTM FAILED TO DEACTIVATE message 6-27  
MTM INPUT FAILURE message 6-27  
MTY FAILED TO ACTIVATE message 6-27  
MTY FAILED TO DEACTIVATE message 6-27  
MTY INPUT FAILURE message 6-27  
MUFE FAILED TO ACTIVATE message 6-28  
MUFE FAILED TO DEACTIVATE message 6-28  
MUFE INPUT IS LOW message 6-28  
MUSE FAILED TO ACTIVATE message 6-28  
MUSE FAILED TO DEACTIVATE message 6-28  
MUSE INPUT IS LOW message 6-28  
mView application 1-21

## N

NBZX, Nudging Buzzer Auxiliary Output 5-45  
NCD, Car Not Done (Emergency Power Return) Output 5-45  
NDGBPS, Nudging bypass flag 5-10  
NDGBPSR, Nudging bypass flag (rear) 5-10  
NDGF, Nudging function flag 5-10  
NDGRX, Rear Door Nudging Auxiliary Output 5-45  
NDGX, Door Nudging Auxiliary Output 5-45  
NDS, Hall door timer non-shorten flag 5-10  
NDSR, Hall door timer non-shorten (rear) flag 5-10  
NEW YORK CITY FIRE PHASE 2 AND ANSI 89 option 5-20  
nomenclature, description of 2-6  
Normal Operation message 6-29  
NSI, Non-Stop (Attendant Service) Input 5-35  
NUDG, Nudging output flag 5-10  
NUDGING DURING FIRE PHASE 2 option 5-23  
NUDGR, Nudging output (rear) flag 5-10  
Number of cars configured 5-70  
NUMBER OF MOTOR STARTERS (1-3) option 5-53  
NYCHA 6-3  
NYDS, New York door shortening flag 5-10

## O

OFR, One Floor Run Output 5-46  
OFRP BETWEEN FLRS option 5-52  
OFRP, One Floor Run Programmable Output 5-46  
OLM INPUT FAILURE message 6-29  
OLM INPUT IS LOW message 6-29

- OLW, Overloaded Car Threshold Output 5-46
- Operating Mode Descriptions
  - Attendant Service Operation 1-14
  - Capture for Test 1-18
  - Car Recall Operation 1-17
  - Emergency Medical Operation 1-15
  - Emergency Power Operation 1-17
  - Fire Service Operation 1-16
  - Hospital Service Operation 1-16
  - Independent Service Operation 1-14
  - Inspection Operation 1-12
  - Sabbath Operation 1-15
  - Test Mode Operation 1-18
- OPERATION (DISPATCHING OPERATION) option 5-17
- OPN/CLS INTRLOCK TIMER 5-28
- options, setting to default values 5-13
- OTHER CAR SERVES FRNT/FLR 1? option 5-18
- OTHER CAR SERVES REAR/FLR 1? option 5-18
- Overload Condition message 6-29
- OVL, Overload Input 5-35
- OVL2, Overload 2 Input 5-35

## P

- parameters, setting to default values 5-13
- PARKING DELAY TIMER 5-27
- PARKING FLOOR option 5-19
- Passcode Request message 5-5, 6-29
- Passcode Requested message 5-61
- password
  - entering the computer security password 5-5
- PC Board Quick References 6-35–??
  - HC-CHP CAN Hub and Power Supply Board 6-36
  - HC-CTL Control Board 6-38
  - HC-DVR Driver Board 6-48
  - HC-MPU Main Processor Board 6-51
  - HC-RDR Rear Door Board 6-54
- PFGE, Passing floor gong output flag 5-10
- PFGE, Passing Floor Gong Enable Input 5-36
- PFGX, Passing Floor Gong Auxiliary Output 5-46
- PH1, Fire Service Phase I Return Complete Output 5-46
- PH1, Phase 1 return complete flag 5-10
- PHE, Photo eye input flag 5-10
- PHER, Photo eye input (rear) flag 5-10
- PHERX, Rear Photo Eye Auxiliary input 5-36
- PHEX, Photo Eye Auxiliary input 5-36
- PHOTO EYE ANTI-NUISANCE? option 5-48
- PI OUTPUT TYPE option 5-48
- PI TURNED OFF IF NO DEMAND? option 5-50
- PI1 - PI8 Position Indicator outputs 5-46
- PI1 - PI8, Position Indicator ourputs (discrete) 5-46
- PIC, PI correction flag 5-10
- PITFLD, Pit Flood inut 5-36
- Placing calls from the controller 4-3, 5-67
- PMT 6-3
- Power line fluctuation 2-3
- Power Transfer Input Active message 6-29
- PRE-OPENING option 5-23
- PRESSURE SWITCH ACTIVATED message 6-29
- PREVENT DCP TIL DOORS CLOSE? option 5-25

- PRIFLG, Priority Service Output 5-46
- Program Mode 5-14–5-54
- PSS, Pressure Switch Input 5-36
- PTI, Power Transfer Input 5-36
- PTIC, Complimented PTI input 5-36
- pump motor
  - wiring 2-9

## R

- R2, Absolute floor encoding #2 flag 5-10
- R2AB, 2AB Relay Redundancy Monitoring Input 5-36
- R2L INPUT FAILURE message 6-29
- R3, Absolute floor encoding #3 flag 5-10
- R4, Absolute floor encoding #4 flag 5-10
- R5, R4, R3, R2, Floor Encoding Input 5-36
- RBAB, BAB Relay Redundancy Monitoring Input 5-36
- RDLSR, Rear Door Lock Relay Redundancy Input 5-36
- RDR SPA IS OFFLINE message 6-30
- RDR SPB IS OFFLINE message 6-30
- REAR CAR DOOR BYPASS SW. FAILURE message 6-30
- Rear DOL & DLK are Both Active message 6-30
- REAR DOOR CLOSE LIMITS option 5-54
- Rear Door is Locked but not fully closed message 6-30
- Rear Door Lock Switch Failure message 6-30
- REAR DOOR MECH. COUPLED option 5-25
- Rear Door Open Limit Failure message 6-30
- Rear Gate Switch Failure message 6-30
- REAR HOISTWAY DOOR BYPASS SW. FAILURE message 6-31
- REAR, Rear door flag 5-10
- Receive/Transmit screen 5-71
- REDUCE HCT WITH PHOTO EYE option 5-25
- Redundancy Door Lock Relay Failure message 6-31
- Redundancy Front Gate Switch Failure message 6-31
- Redundancy Rear Gate Switch Failure message 6-31
- Refresh Device 5-71
- Refresh XPort 5-71
- Registering car calls 4-3, 5-67
- relevel operation, description 4-6
- REO, Re-Open Input 5-36
- REO, Re-Open Input option 5-36
- Re-Open Input 5-36
- Reset XPort screen 5-71
- Resolving Faults 3-5
- RESTORING SAFETY message 6-31
- RETAIN CALLS ON CTL/CTF option 5-49
- RETIRING CAM option 5-22
- RFI 2-3
- RFV INPUT FAILED TO ACTIVATE message 6-31
- RFV INPUT FAILED TO DEACTIVATE message 6-31
- RFV, Redundancy Fast Valve input 5-36
- RGSR, Redundancy Gate Switch (rear) input 5-37
- RINAX, INAX Relay Redundancy Monitoring Input 5-37
- RP SENSOR TRIPPED message 6-32
- RSG, Redundancy Gate Switch (front) input 5-37
- RSV INPUT FAILED TO ACTIVATE message 6-32
- RSV INPUT FAILED TO DEACTIVATE message 6-32
- RSV, Redundancy Slow Valve input 5-37
- RUN, Run flag 5-10



- Using Status and Error Messages 6-3
- Verifying cartop communication 6-64
- Troubleshooting tools 6-2
- TSLB, Bottom Terminal Slow Limit Input 5-37
- TSLT, Top Terminal Slow Limit Input 5-37

## U

- UC, Up call flag 5-11
- UCA, Up call above flag 5-11
- UCB, Up call below flag 5-11
- UCR, Up call (rear) flag 5-11
- UDP, Up direction preference flag 5-11
- UFL, Up Final Limit Input 5-37
- UFP, Upper parking floor flag 5-11
- UFQ, Up first qualifier flag 5-11
- UP AND DOWN TERMINAL SPEED REDUCING LIMITS OPEN message 6-34
- UP NORMAL LIMIT OPEN message 6-34
- UP TERMINAL LIMIT FAILURE message 6-34
- UP TO SPEED TIMER option 5-53
- UPD, Up previous direction flag 5-11
- UPDO, Up direction output flag 5-11
- UPI, Up Input (Attendant Service) 5-38
- UPO, Up Output (Attendant Service) 5-46
- UPS, Up direction sense input flag 5-11
- UPS, Up Sense output 5-46
- USD, Up slow down input flag 5-11

## V

- VALVE LIMIT TIMER 5-27
- Valve Limit Timer (Anti-stall) Elapsed message 6-34
- VALVE TYPE option 5-54
- VCA, Viscosity active flag 5-11
- VCI, Viscosity Control Input 5-38
- VCI, Viscosity Input flag 5-11
- Version number of the monitoring software 5-70
- View assigned spare outputs 5-39
- Viscosity Control Function message 6-34
- VLT, Valve limit timer flag 5-11

## W

- WHITE PLAINS, NY FIRE CODE option 5-20
- WILL THIS CAR RUN ON PH2? option 5-20
- wiring
  - controller wiring 2-7
  - ground wiring 2-8, 2-9
  - main AC power 2-9
  - pump motor 2-9
- wiring prints, description of 2-5
- WLD, Emergency Dispatch Input 5-38
- WLDI, Wild Operation Indication Output 5-47
- WPIx (A - H), Wandering Patient Security (Bracelet Security) inputs 5-38
- WPIx LANDING? (x = A thru H) parameter 5-49

## X

- XDSA, Auxiliary Supervisory Down Arrow Output 5-47
- XPI1-XPI7, Auxiliary Position Indicators 1 thru 7 Outputs 5-47
- XPort Comm Resets screen 5-71
- XSUA, Auxiliary Supervisory Up Arrow Output 5-47

## Y

- Y-D OPEN TRANSN. TIMER option 5-53
- Y-D TRANSFER TIMER option 5-53
- YRD INPUT FAILURE message 6-34

## Z

- ZADJ, Zero Adjust Output 5-47