

DESIGNER	D. LIGNELL	DRN.	DPL	PRODUCT CODE	TWS600 SCD	LANGUAGE	EN	M-FILM
DATE	94/28	DEPT.	HEC	CHO.	APPO.	REG.	ISSUE	
DRIVE MODULE: POWER SUPPLIES								
ISSUE	ALTERNATION	DATE	DRN.	APPO.	M-FILM			
CIRCUIT DIAGRAM						508610E04 1/3		PAGE 1

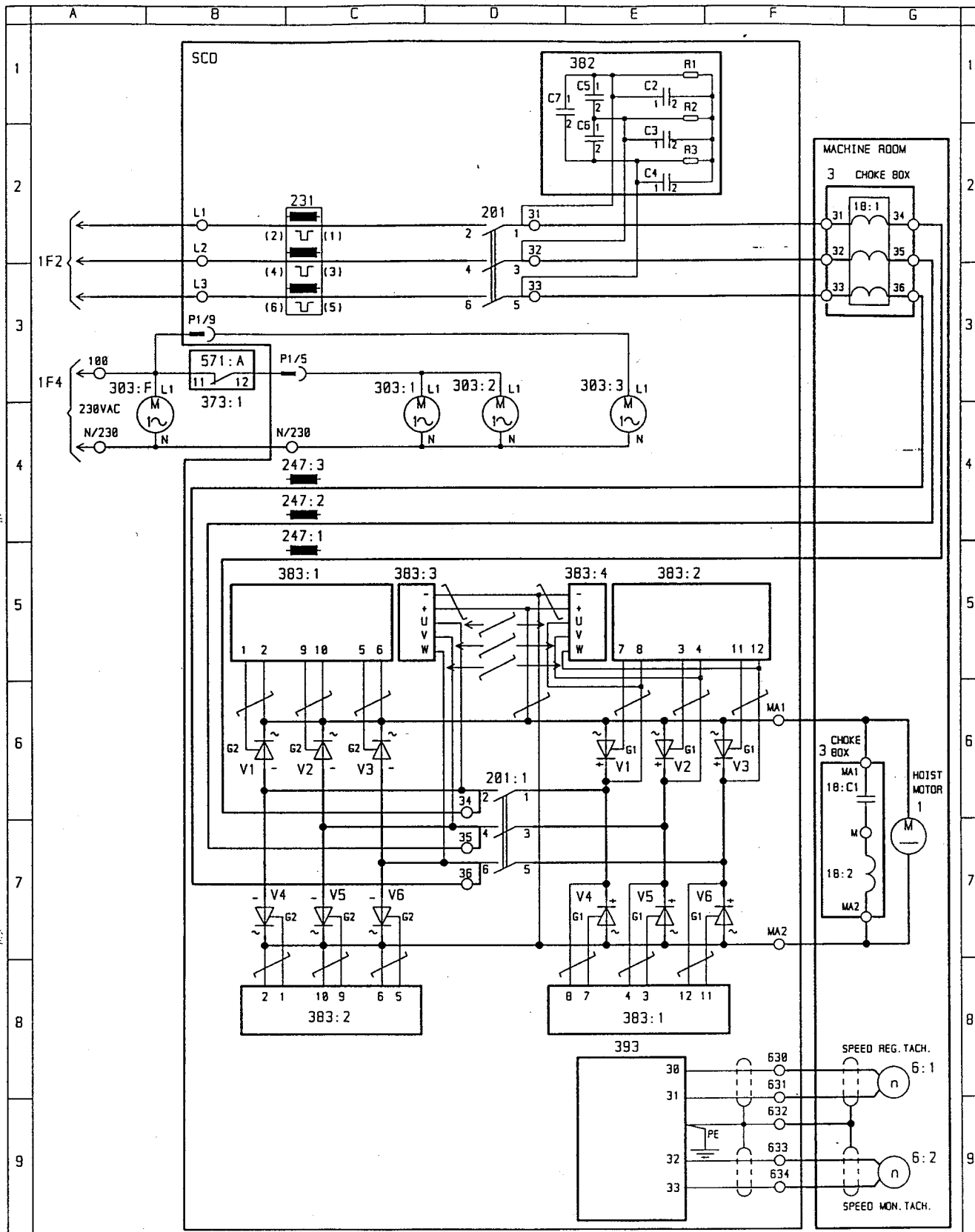

DESIGNER	O. LIGNELL	DRN.	OPL	PRODUCT CODE	TMS600 SCD	LANGUAGE	EN	M-FILM
DATE	94/28	DEPT.	HEC	CHD.	APPO.	REG.		ISSUE
DRIVE MODULE; HOIST MOTOR								
KONE								

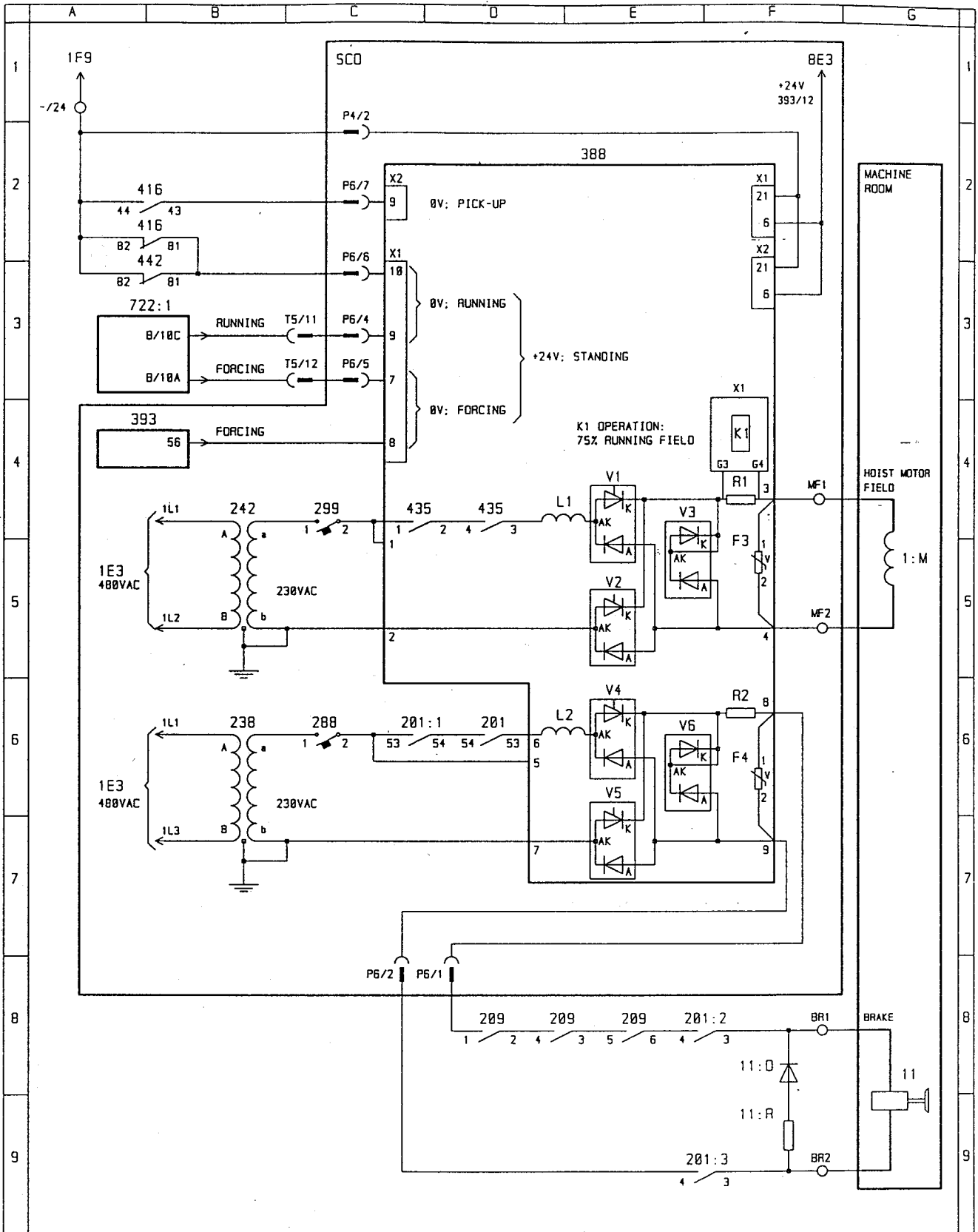

					DESIGNER O. LIGNELL	DRN. OPL	PRODUCT CODE TMS600 SCO	LANGUAGE EN	M-FILM
					DATE 94/28	DEPT. HEC	CHD.	APPO.	ISSUE
					KONE				
					DRIVE MODULE; BRAKE AND FIELD				
ISSUE	ALTERNATION	DATE	DRN.	APPO.	M-FILM				PAGE 3

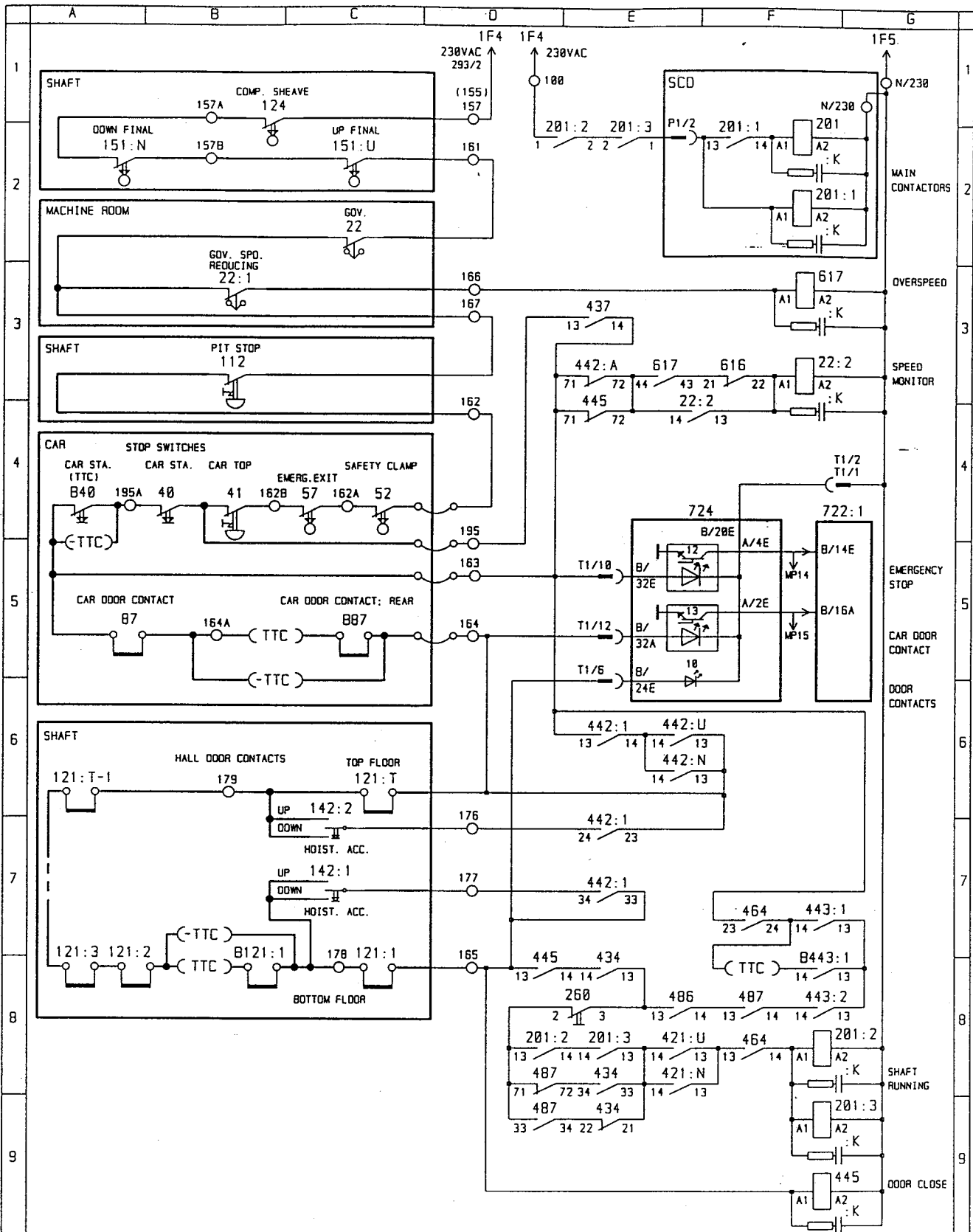

DESIGNER	O. LIGNELL	DRN.	DPL	PRODUCT CODE	TMS600 SCD	LANGUAGE	EN	M-FILM
DATE	94/28	DEPT.	HEC	CHD.	APPD.	REG.		ISSUE
KONE SAFETY CIRCUIT								
ISSUE	ALTERNATION	DATE	DRN.	APPO.	M-FILM	TWIN COPY		
CIRCUIT DIAGRAM						508610E05		PAGE 4

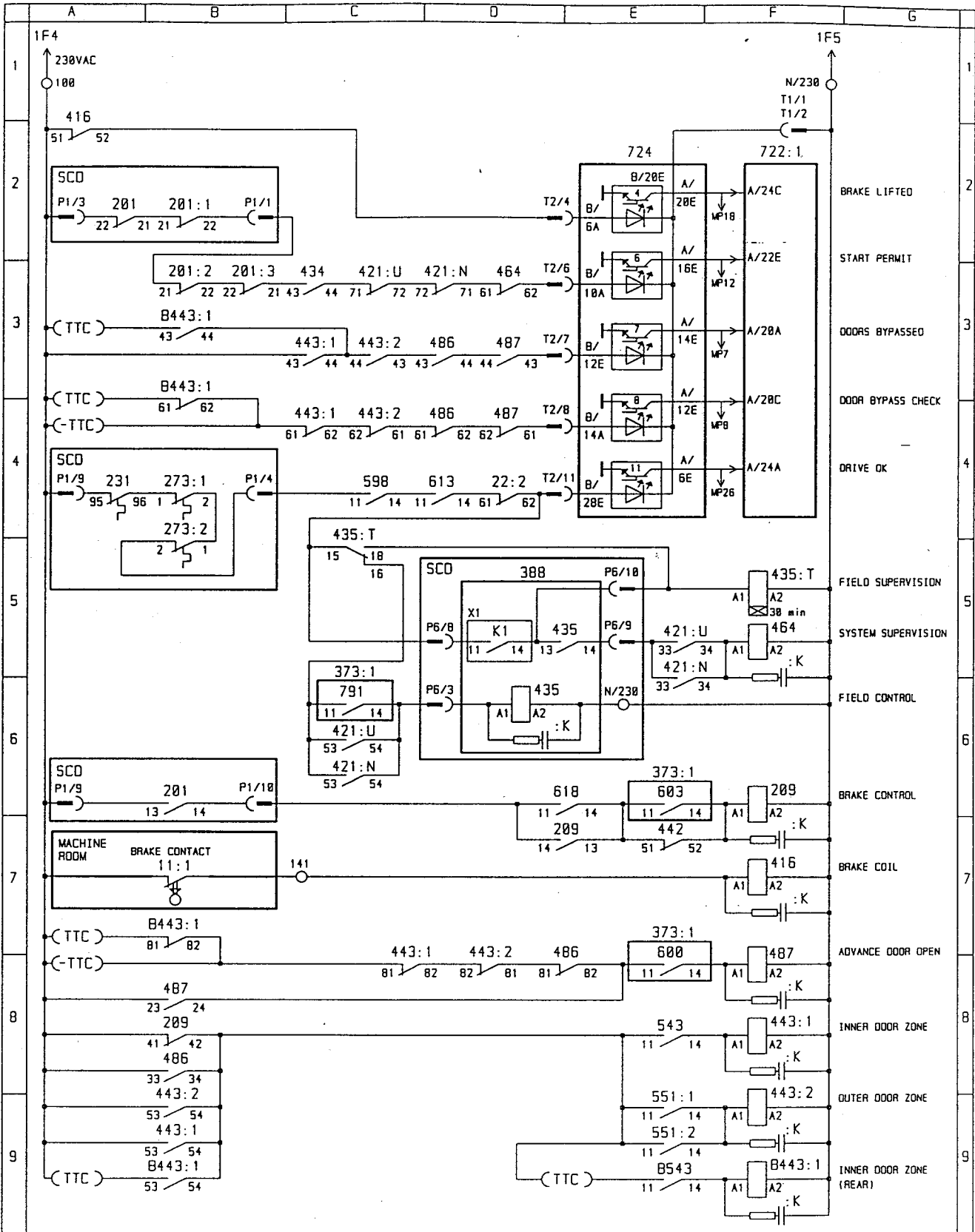

DESIGNER O. LIGNELL	DRW. OPL	PRODUCT CODE TMS600 SCD	LANGUAGE EN	M-FILM
DATE 94/28	DEPT. HEC	CHG. APPO.	REG.	ISSUE
KONE				
DRIVE CONTROL: CONTACTORS				
ISSUE	ALTERNATION	DATE	DRW.	APPO.
CIRCUIT DIAGRAM			508610E06 1/3	
				PAGE 5

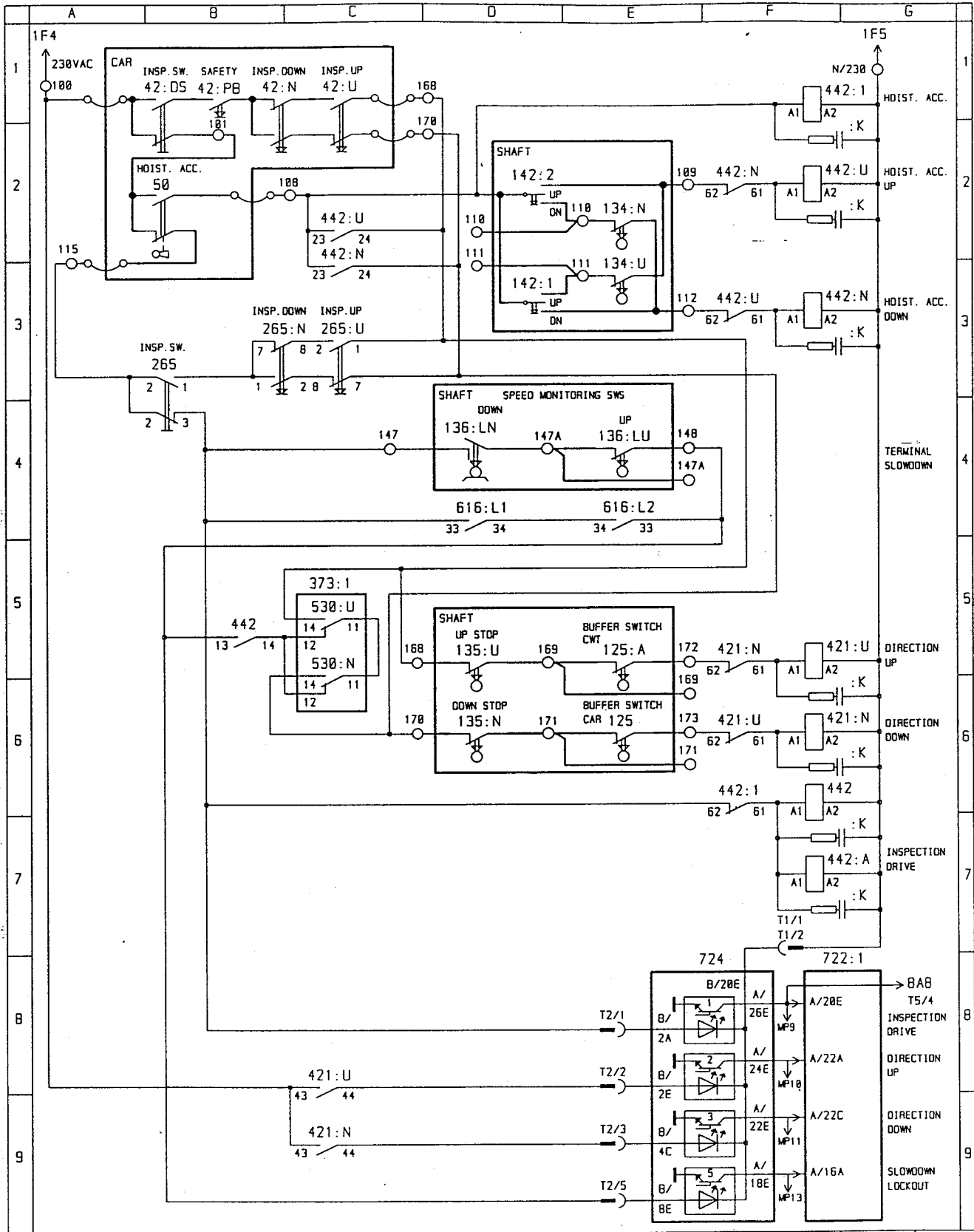

					DESIGNER D. LIGNELL	DRN. DPL	PRODUCT CODE TMS600 SCO	LANGUAGE EN	M-F FILM
					DATE 94/28	DEPT. HEC	CHG. APPO.	REG.	ISSUE
					KONE				
					DRIVE CONTROL; INSPECTION DRIVE				
ISSUE	ALTERNATION	DATE	DRN.	APPD.	M-FILM				
					508610E06 2/3				PAGE 6

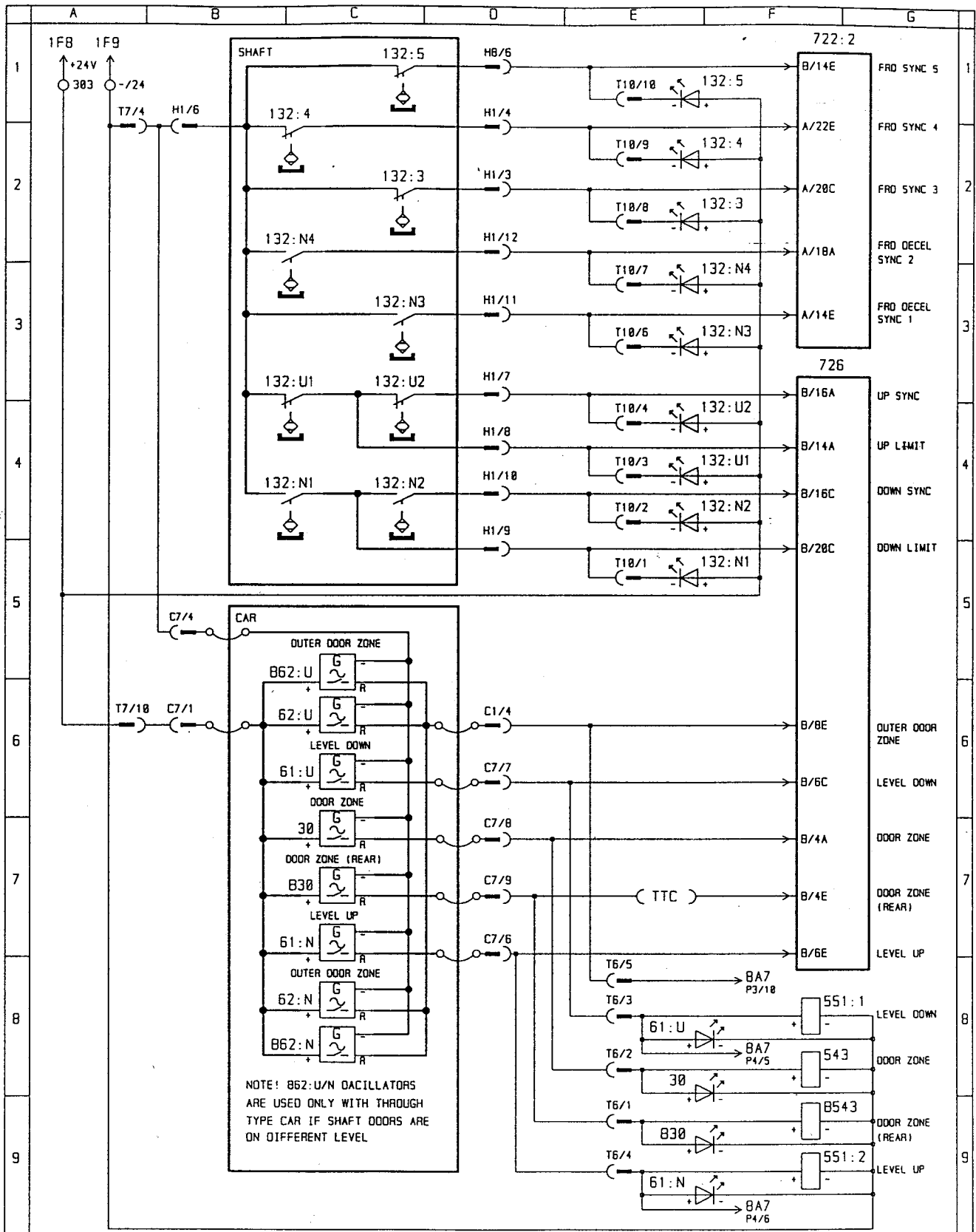

					DESIGNER D. LIGNELL	DRN. OPL	PRODUCT CODE TMS600 SCD	LANGUAGE EN	M-FILM
					DATE 9/4/28	DEPT. HEC	CHD. APPD.	REG.	ISSUE
					KONE				
					DRIVE CONTROL: POSITION INPUTS				
ISSUE	ALTERNATION	DATE	DRN.	APPD.	M-FILM				
CIRCUIT DIAGRAM					508610E06 3/3				PAGE 7

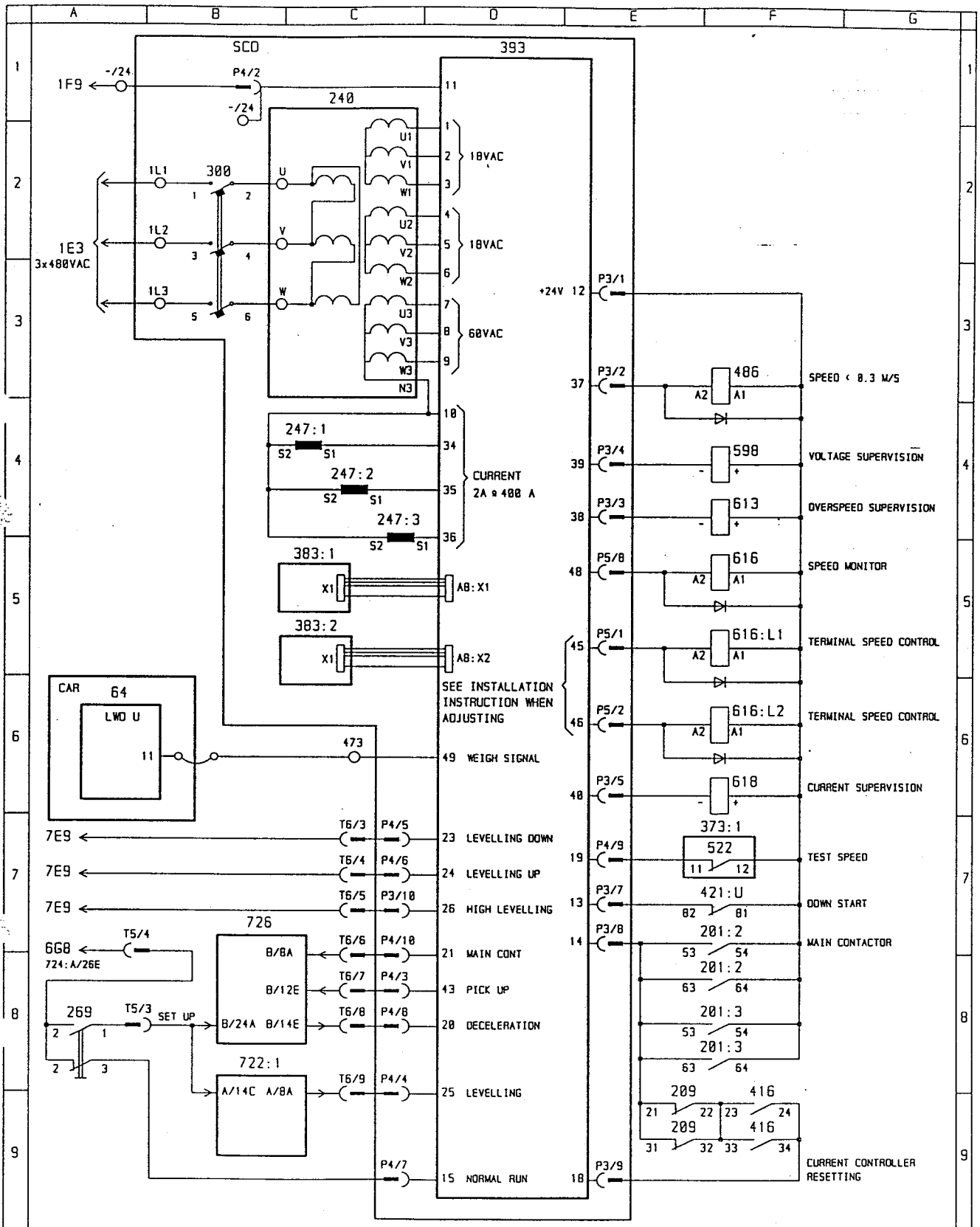

DESIGNER	O. LIGNELL	DRN.	OPL	PRODUCT CODE	TMS600 SCO	LANGUAGE	EN	M-FILM
DATE	9/28	DEPT.	HEC	CHD.	APPO.	REG.		ISSUE
CONTROL MODULE 1								
KONE								
ISSUE	ALTERNATION	DATE	DRN.	APPO.	M-FILM	PAGE 8		

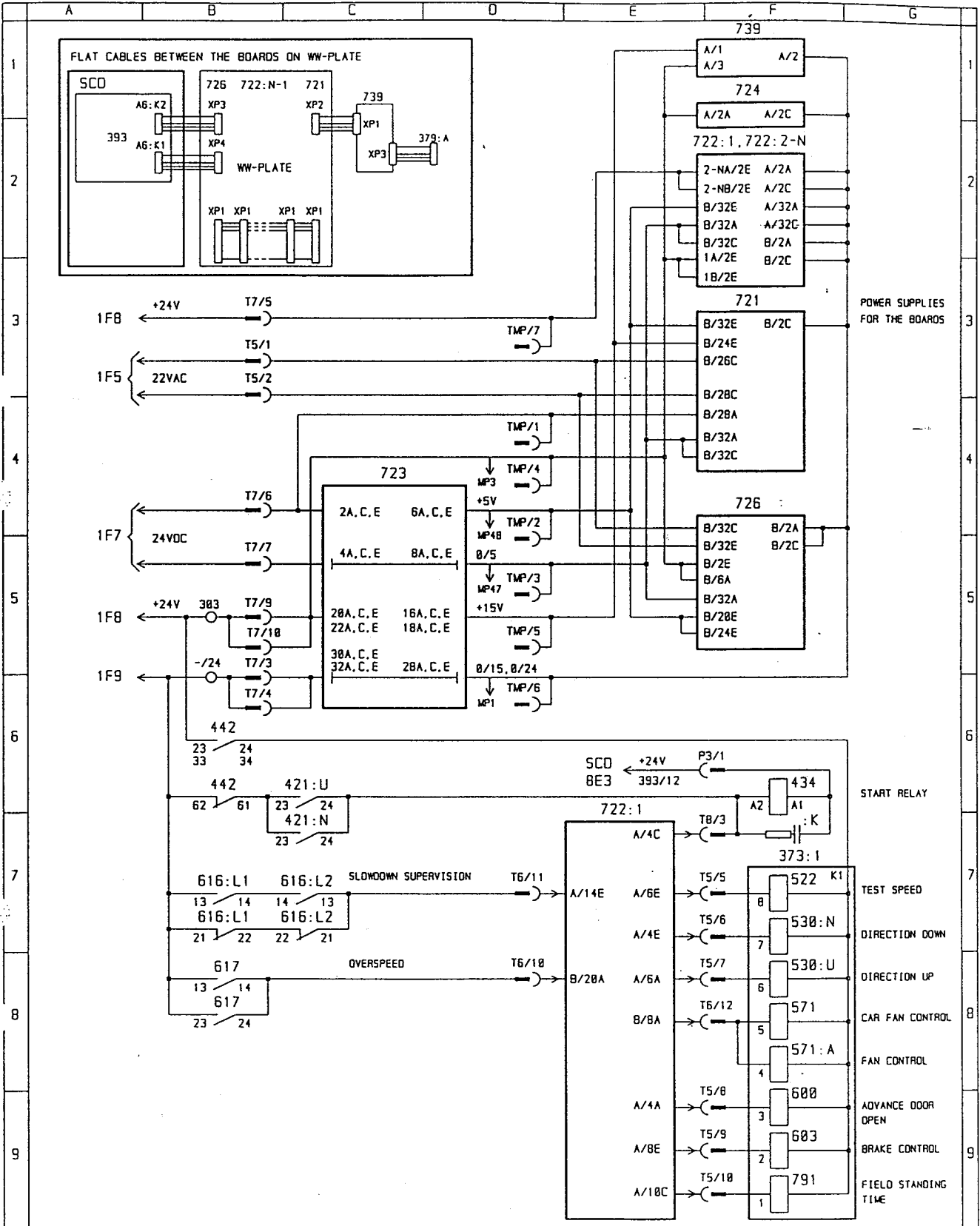

DESIGNER	O. LIGNELL	DRW.	OPL	PRODUCT CODE	TMS600 SCD	LANGUAGE	EN	M-FILM
DATE	94/28	DEPT.	HEC	DRW.	APPO.	REG.		ISSUE
KONE								
CONTROL MODULE 2								
ISSUE	ALTERNATION	DATE	DRW.	APPO.	M-FILM	TYPE COPY		

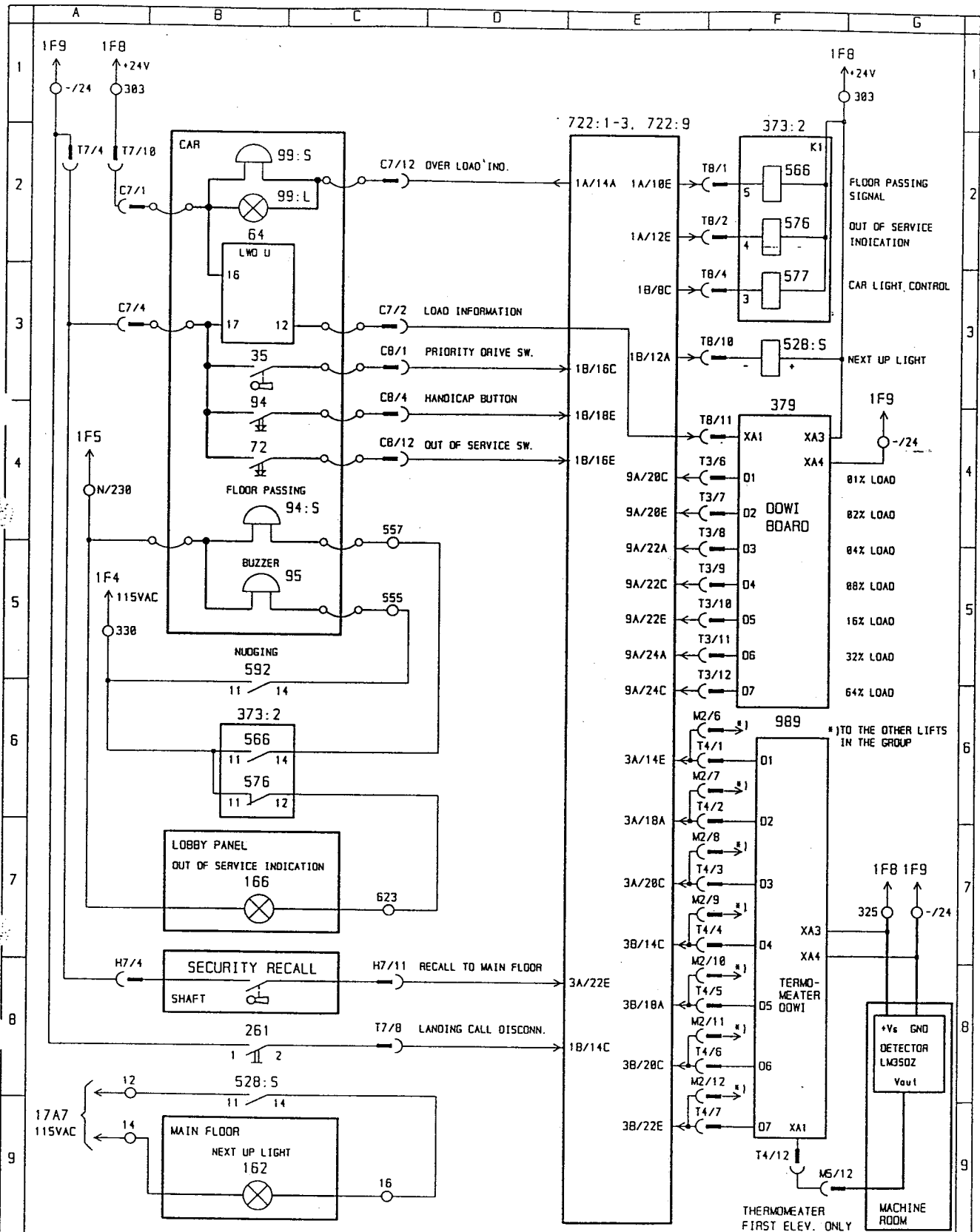

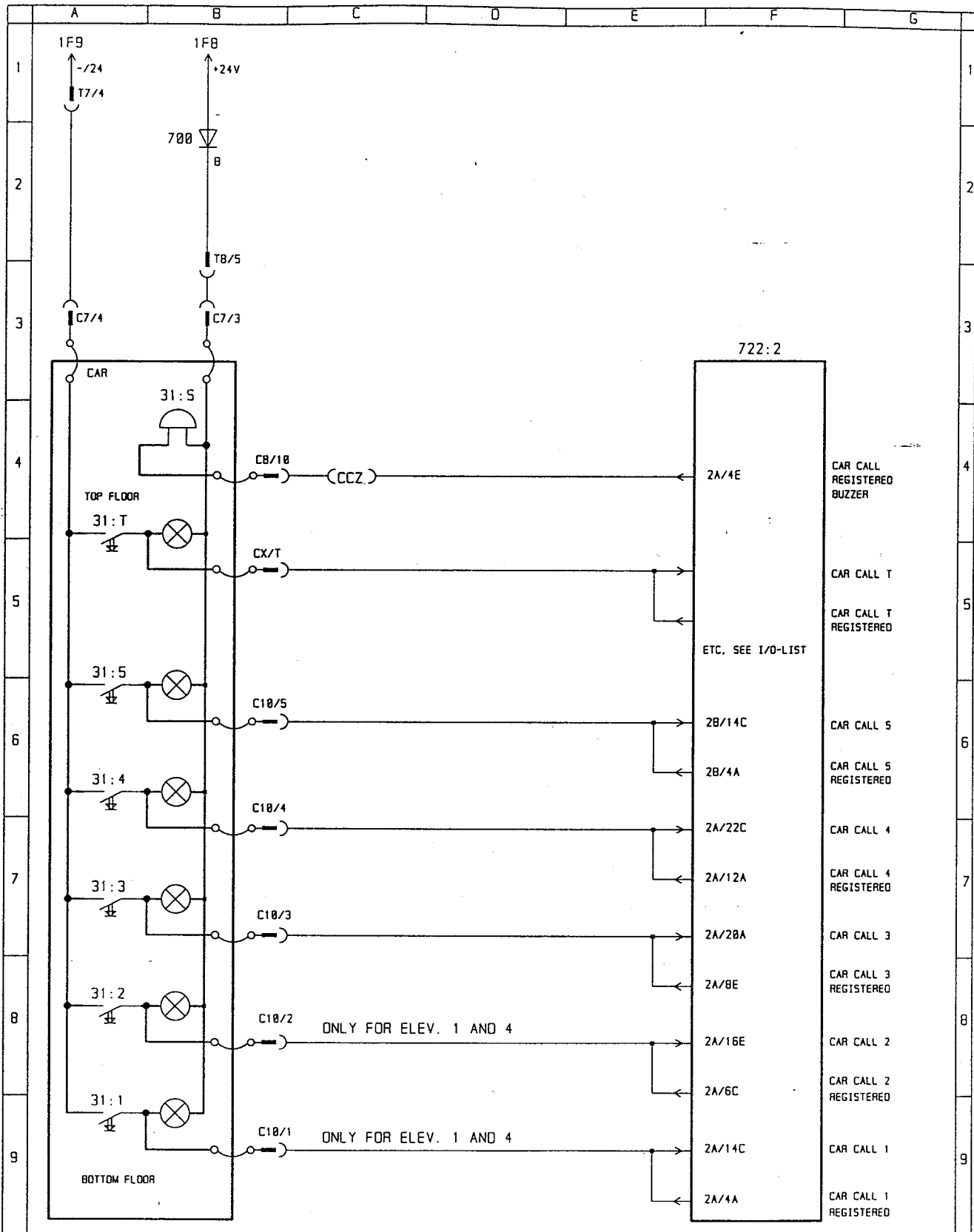

DESIGNER O. LIGNELL	DRN. DPL	PRODUCT CODE TMS600 FC	LANGUAGE EN	M-FILM
DATE 94/20	DEPT. HEC	CHG.	APPD.	REG. ISSUE
KONE				
CAR CALLS				
ISSUE	ALTERNATION	DATE	DRN.	APPD.
				M-FILM

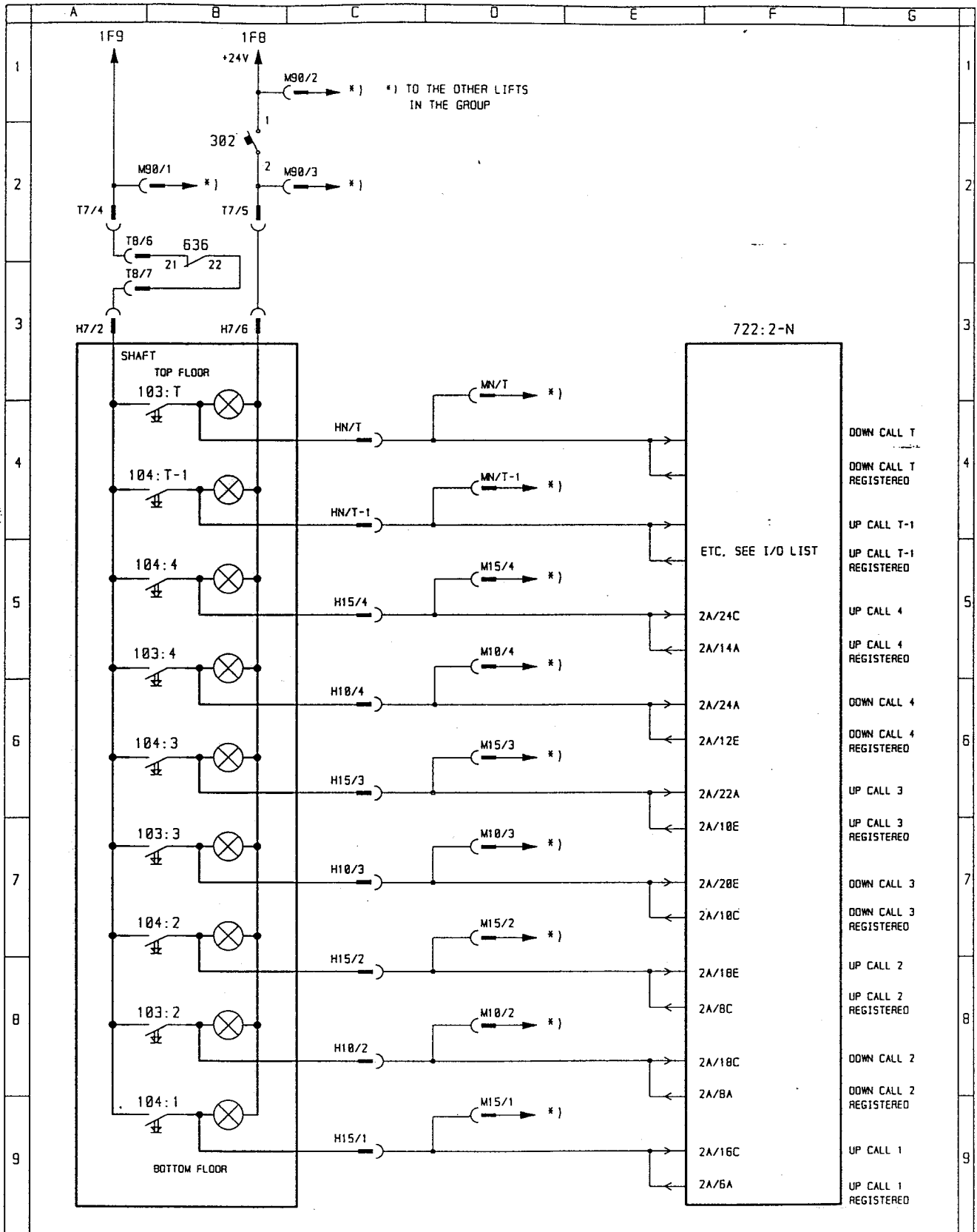

DESIGNER O. LIGNELL	DRN. DPL	PRODUCT CODE TMS600 FC	LANGUAGE EN	M-FILM
DATE 94/28	DEPT. HEC	CHD.	APPD.	ISSUE
KONE				
FLOOR MODULE (LANDING CALLS)				
ISSUE	ALTERNATION	DATE	DRN.	APPD.

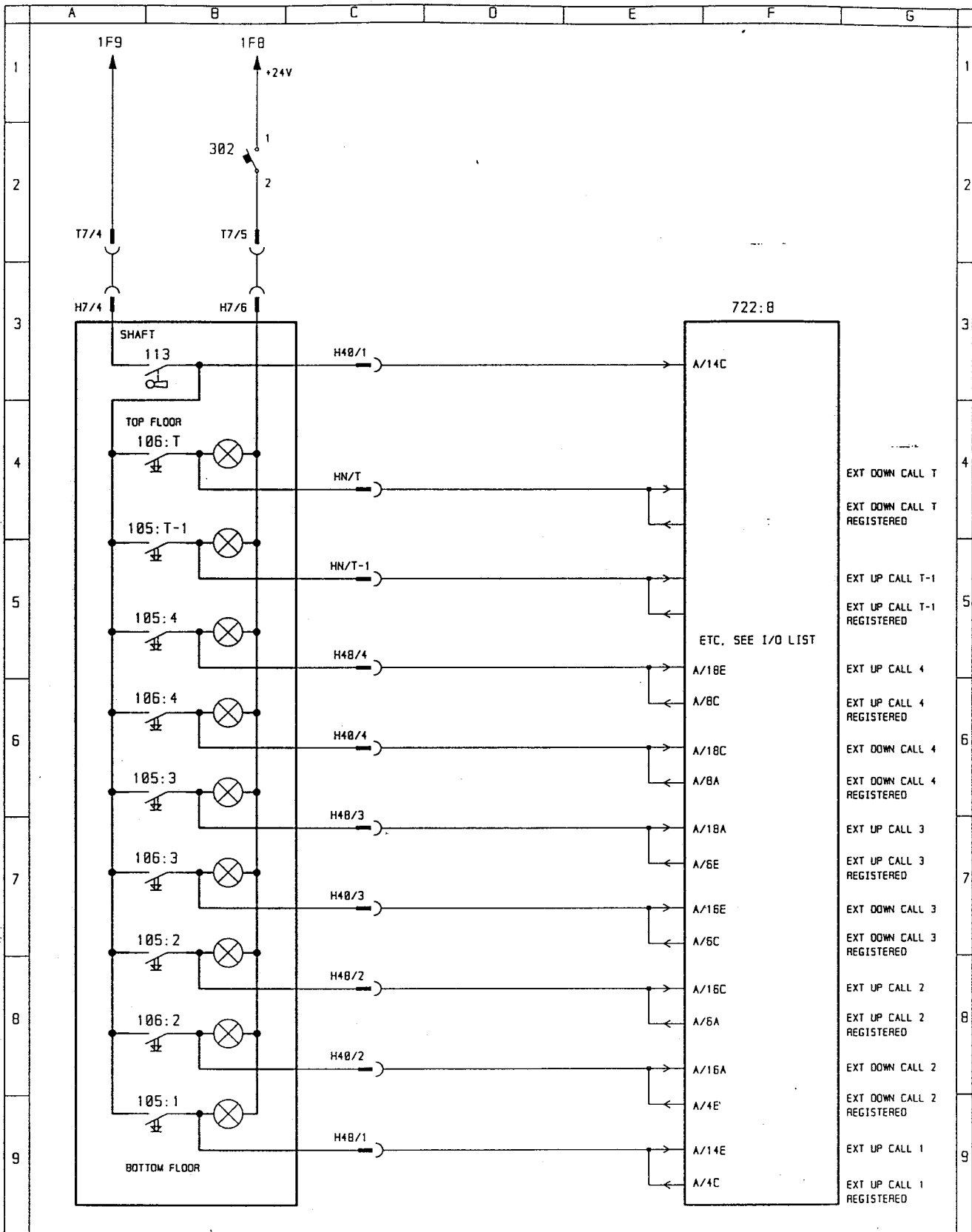

DESIGNER OP. LIGNELL	DRN. OPL	PRODUCT CODE TMS600	LANGUAGE EN	M-FILM
DATE 94/29	DEPT. HEC	CHD.	APPD.	REG. ISSUE
KONE				
SIMPLEX SERVICE				
ONLY FOR ELEV. 1				

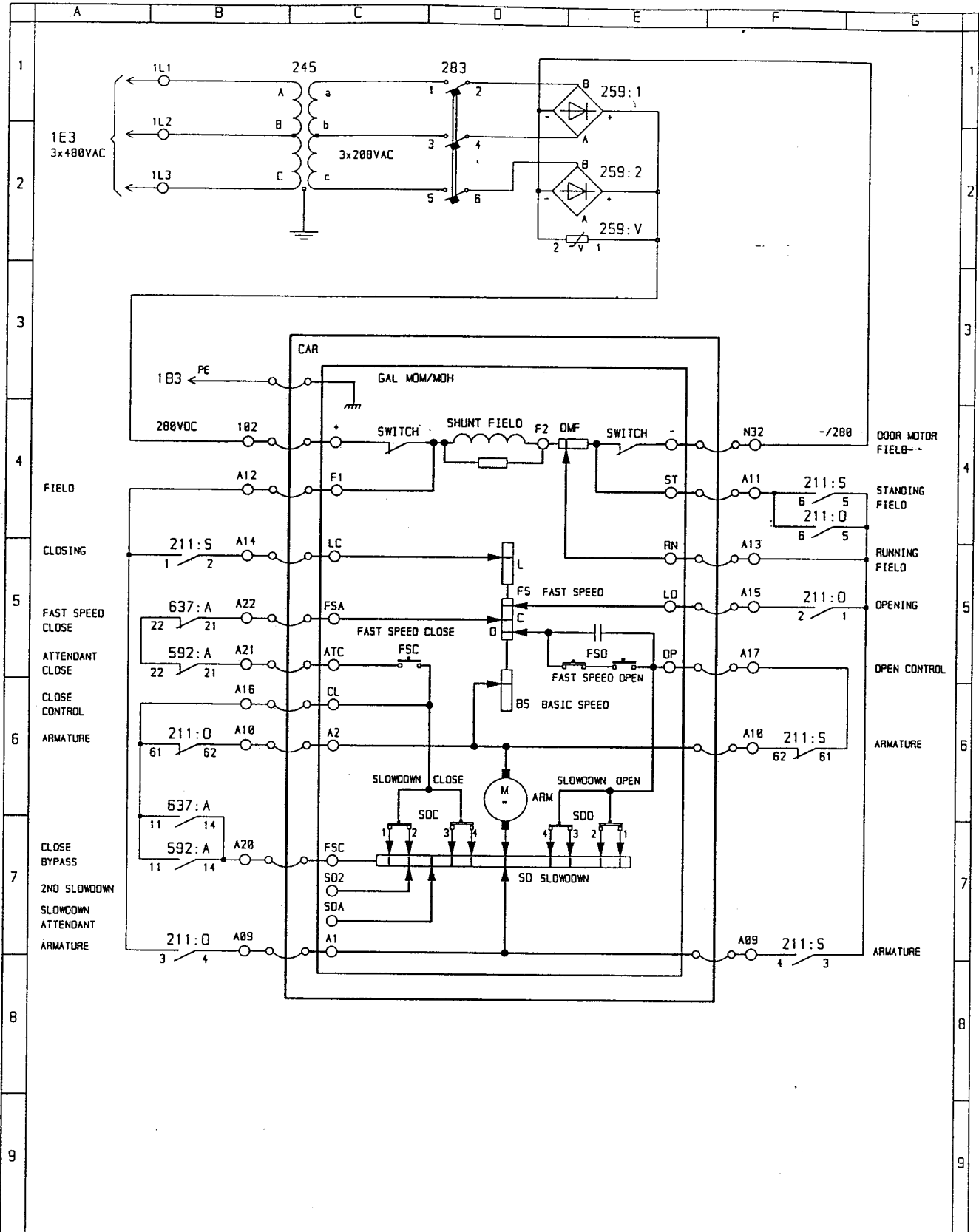

DESIGNER	O. LIGNELL	DRN.	OPL	PRODUCT CODE	TMS500	LANGUAGE	EN	M-FILM
DATE	94/28	DEPT.	HEC	CHD.	APPD.	REG.		ISSUE
DOOR MODULE GAL MOM/MOH; MAIN CIRCUIT								
KONE								
ISSUE	ALTERNATION	DATE	DRN.	APPD.	M-FILM			

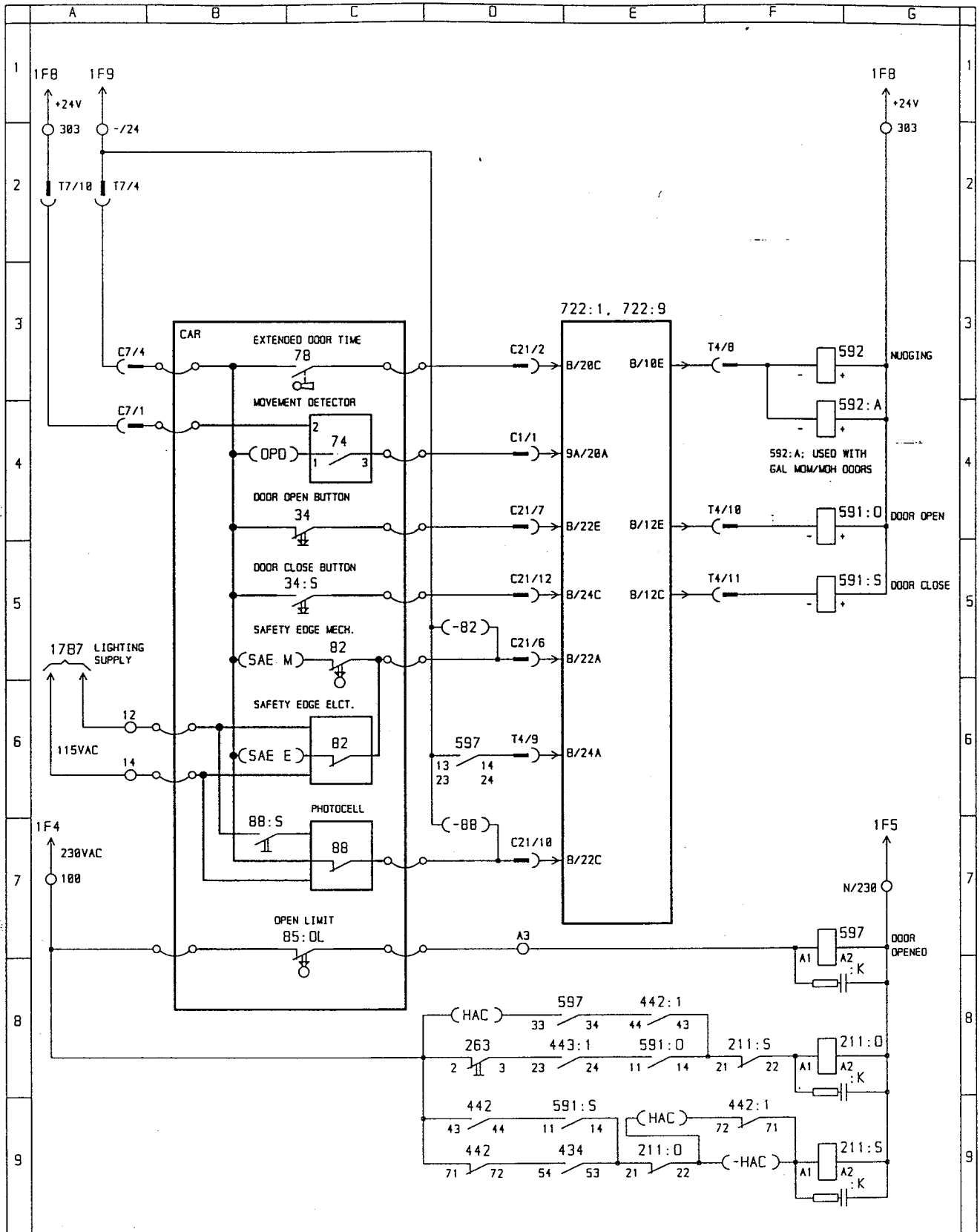

DESIGNER D. LIGNELL	DRN. DPL	PRODUCT CODE TMS688	LANGUAGE EN	M-FILM
DATE 94/28	DEPT. HEC	DRD.	APPO.	ISSUE
KONE				
DOOR MODULE GAL: CONTROL				
ISSUE	ALTERNATION	DATE	DRN.	APPO.

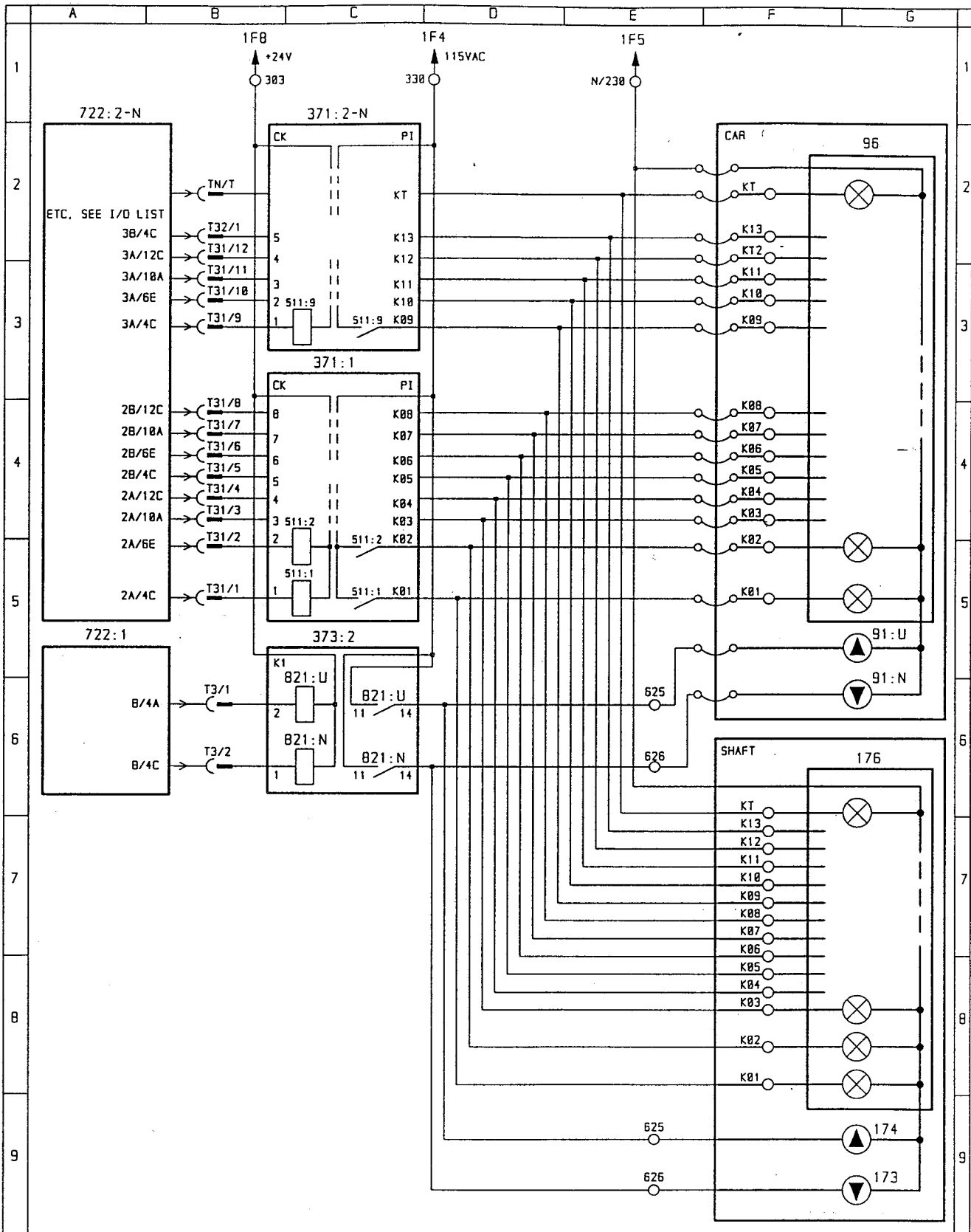

DESIGNER O. LIGNELL	DRW. OPL	PRODUCT CODE TMS600 FC	LANGUAGE EN	M-FILM
DATE 94/28	DEPT. HEC	CHG.	APPD.	REG. ISSUE
KONE				
CAR POSITION INDICATOR (ANALOG)				
ISSUE	ALTERNATION	DATE	DRW.	APPD.

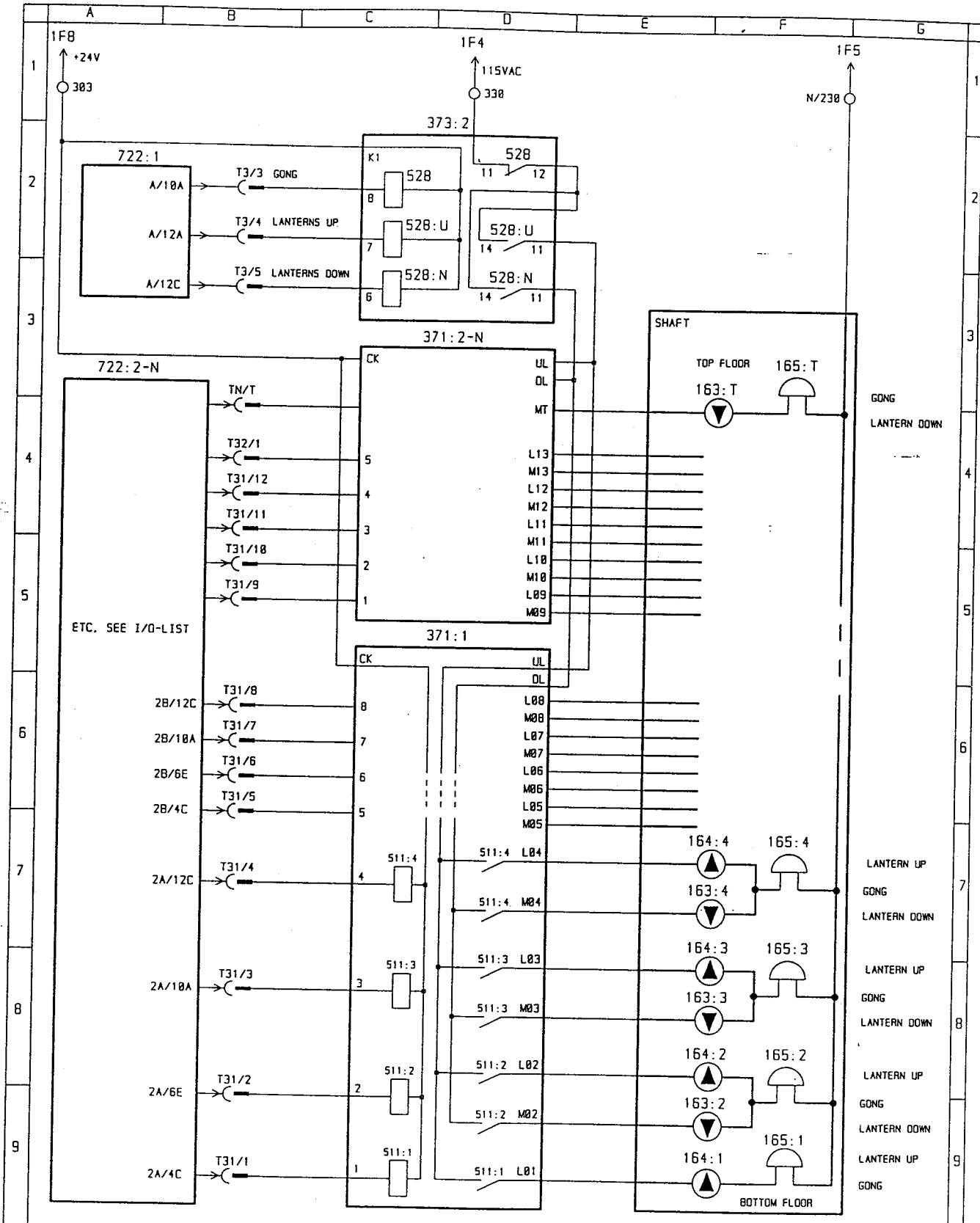

DESIGNER	OP. LIGNELL	DRN.	OPL	PRODUCT CODE	TMS600 FC	LANGUAGE	EN	W-FILM
DATE	94/29	DEPT.	HEC	CHD.	APPD.	REG.		ISSUE
KONE								
HALL LANTERNS AND GONGS								
ISSUE	ALTERNATION	DATE	DRN.	APPD.	W-FILM	1/111 COPY		

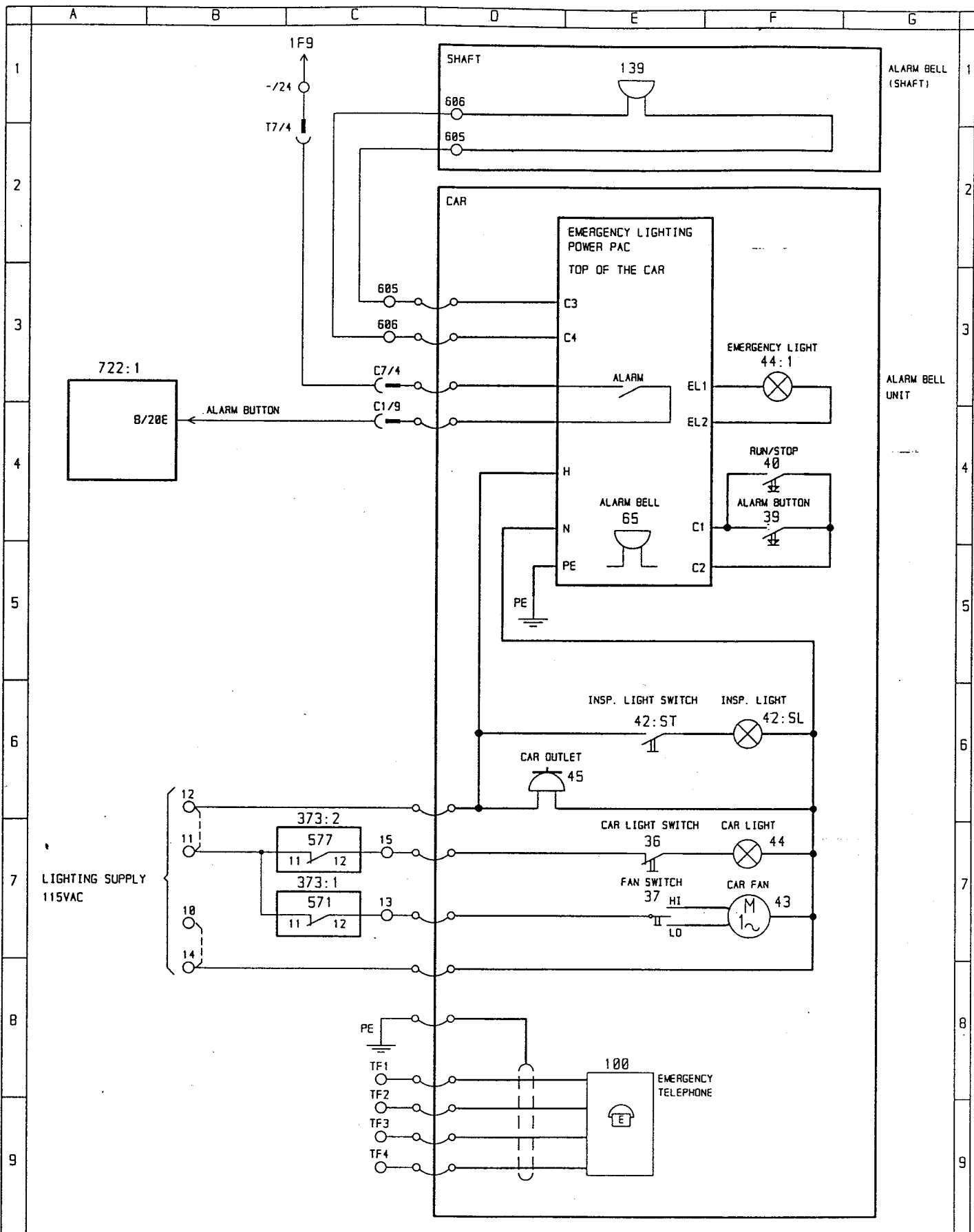

DESIGNER	O. LIGNELL	DRN.	OPL	PRODUCT CODE	TMS600	LANGUAGE	EN	M-FILM
DATE	94/28	DEPT.	HEC	CHD.	APPD.	REG.		ISSUE
KONE								
CAR LIGHTING AND ALARM								

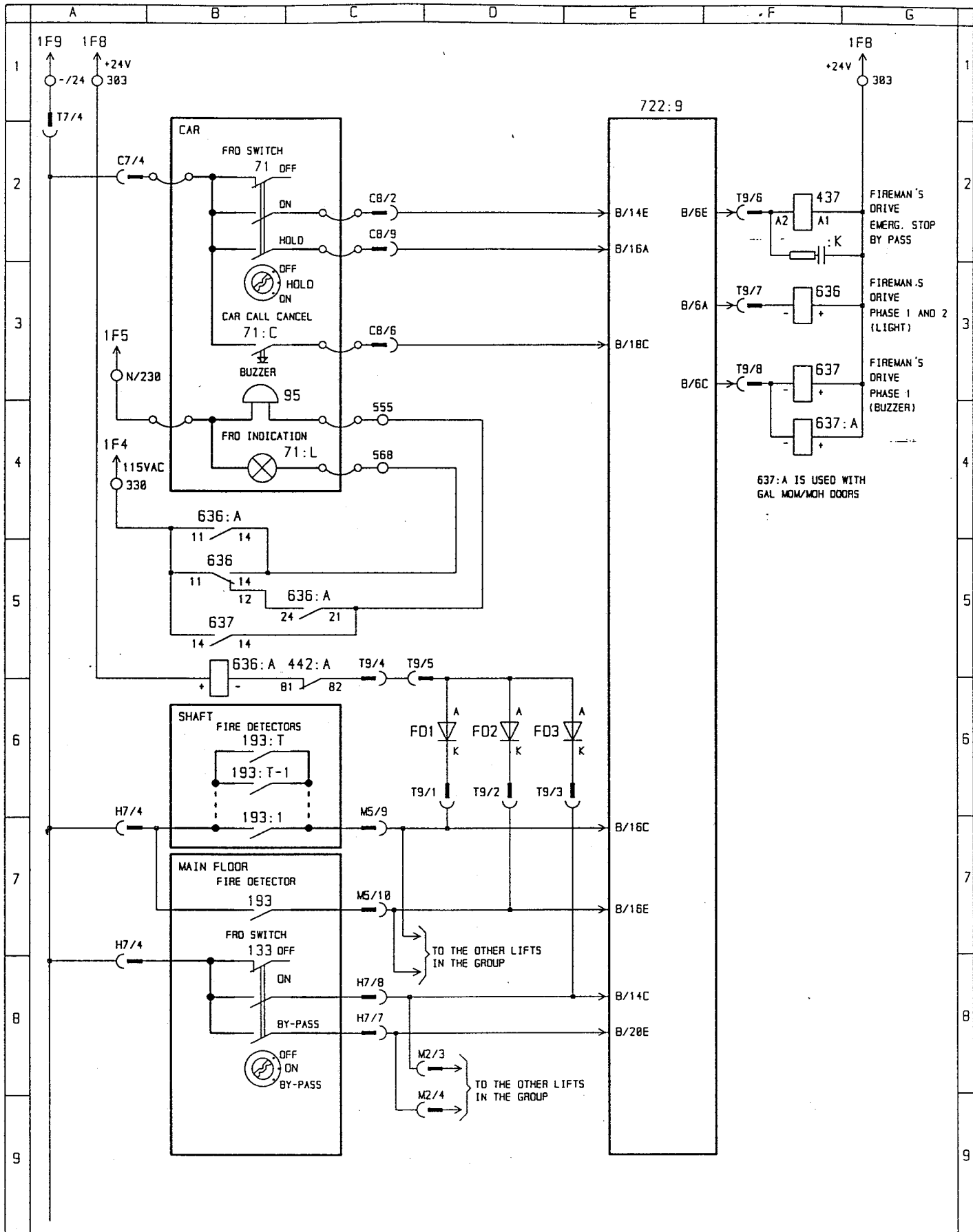

637:A IS USED WITH GAL MOM/MOH DOORS

DESIGNER O. LIGNELL	DRN. DPL	PRODUCT CODE TMS600	LANGUAGE EN	W-FILW
DATE 94/28	DEPT. HEC	CHG.	APPD.	REG. ISSUE



FIREMAN'S DRIVE

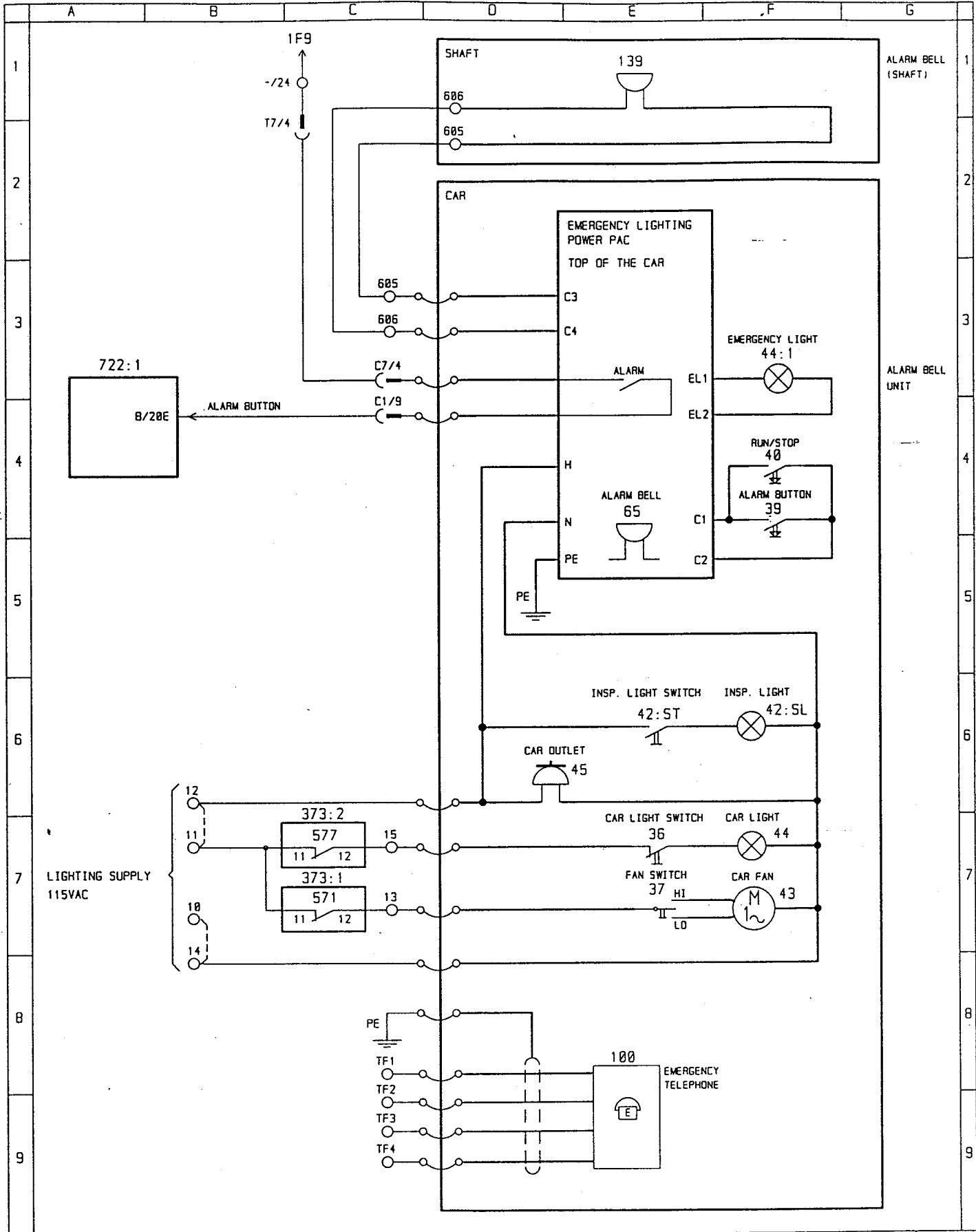

DESIGNER O. LIGNELL	DRN. OPL	PRODUCT CODE TMS600	LANGUAGE EN	M-FILM
DATE 94/28	DEPT. HEC	CHG.	APPO.	REG. ISSUE

CAR LIGHTING AND ALARM



COPY

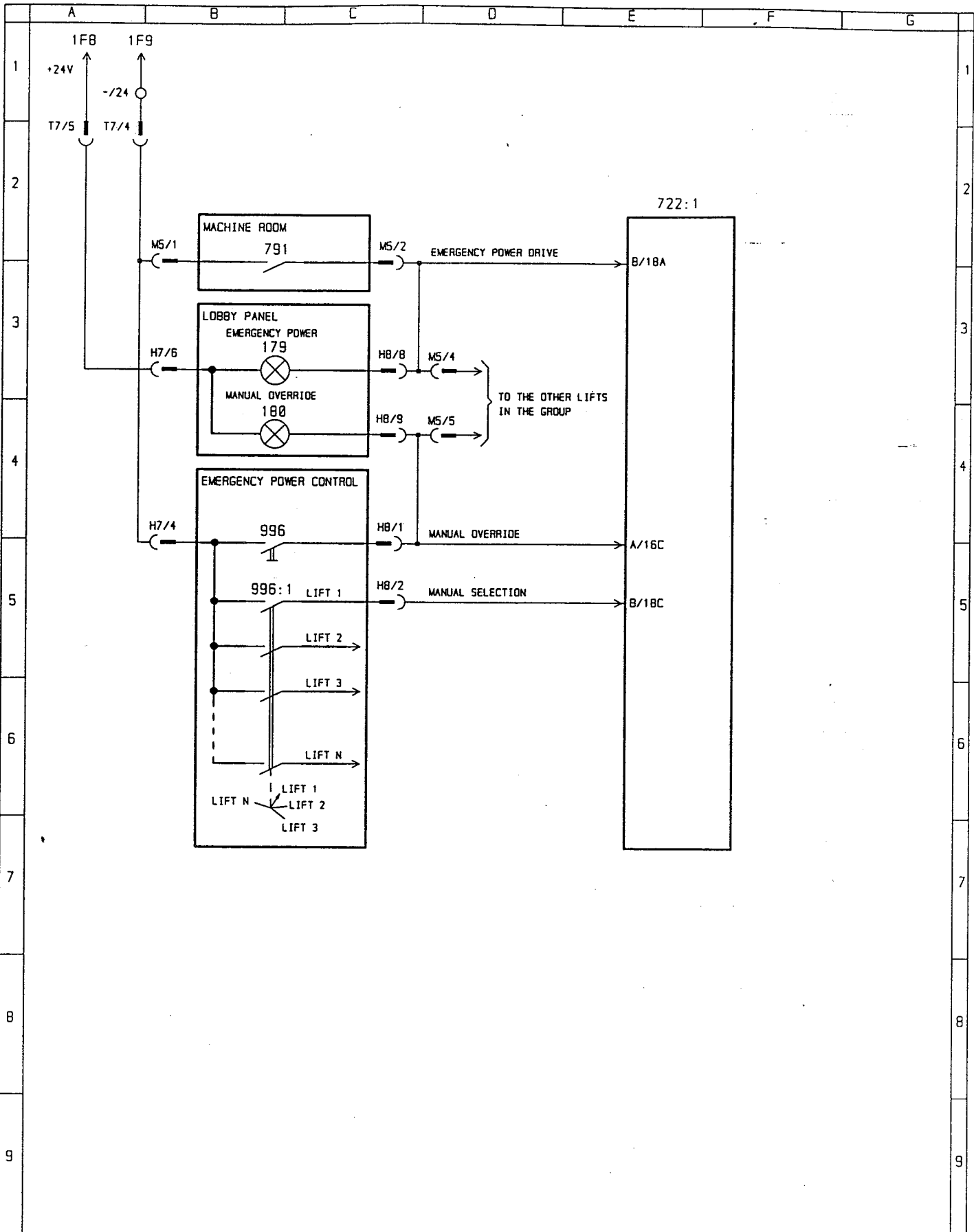

DESIGNER O. LIGNELL	DRN. OPL	PRODUCT CODE TMS600	LANGUAGE EN	M-FILM
DATE 94/28	DEPT. HEC	CHD.	APPO.	REG. ISSUE

EMERGENCY POWER



COPY

COMMON MEMORY CABLE FOR GROUP LIFTS

MACHINE ROOM

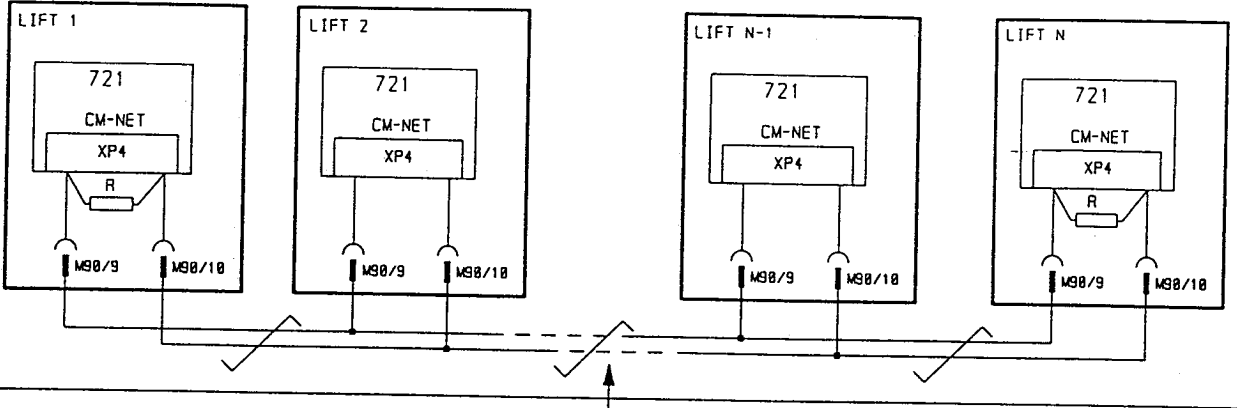

MONITORING SYSTEM

MACHINE ROOM

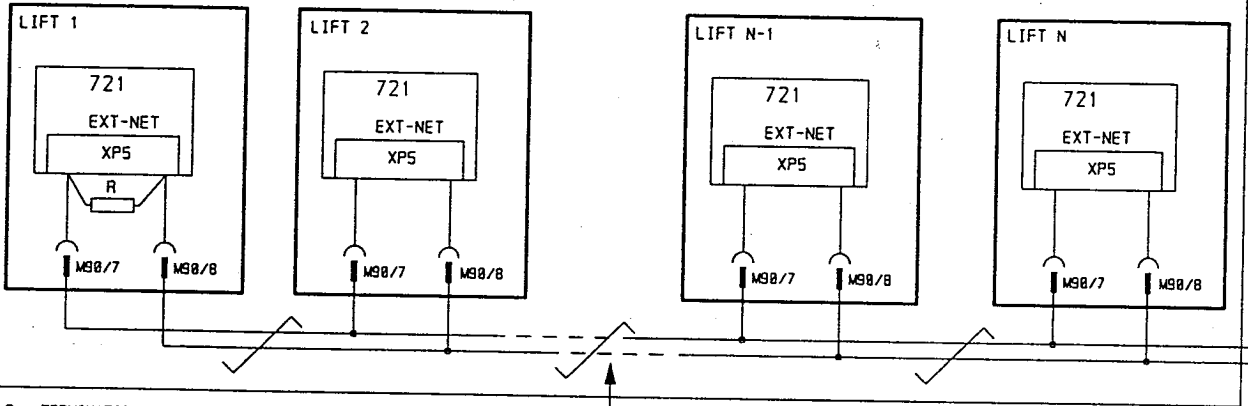

R = TERMINATION RESISTOR (120Ω MIN 0.25 W).
CONNECTED AT THE BEGINNING AND END OF THE CAN-NETWORK.
SEE DRAWING FOR DETAILS.

NOTE! MAX 10 ELEVATORS
PER WORKSTATION

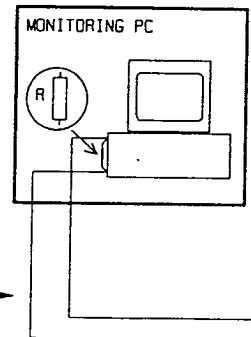

LOCAL SUPPLY
AWG 18, TWISTED 4x/FOOT

DESIGNER O. LIGNELL	DRN. OPL	PRODUCT CODE TMS600	LANGUAGE EN	M-F FILM
DATE 94/28	DEPT. HEC	CHD.	APPO.	REG. ISSUE

CONNECTION OF THE COMMON MEMORY CABLES



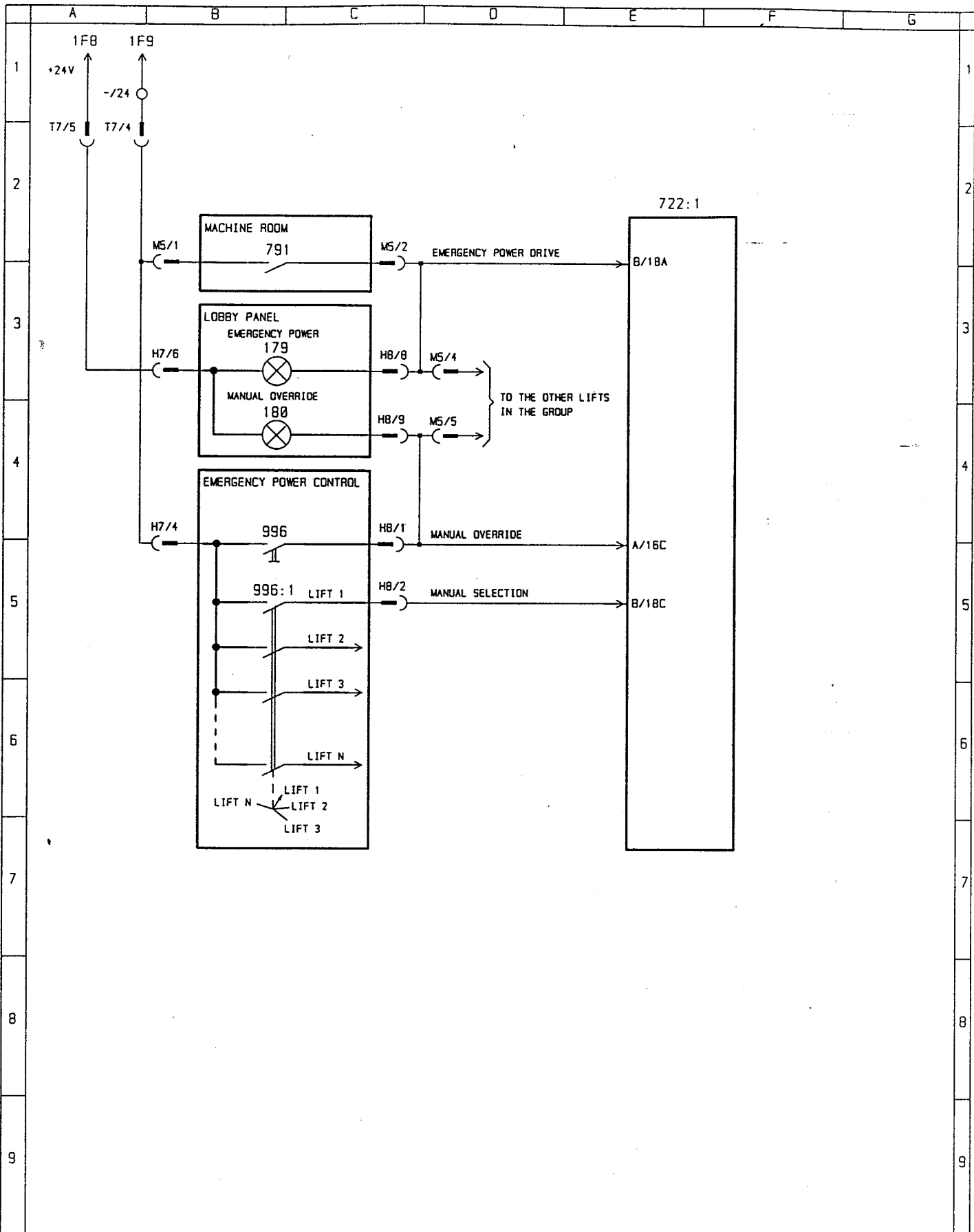

DESIGNER O. LIGNELL	DRN. OPL	PRODUCT CODE TMS600	LANGUAGE EN	M-FILM
DATE 94/28	DEPT. HEC	CHD.	APPD.	REG. ISSUE

EMERGENCY POWER



4 COPY

COMMON MEMORY CABLE FOR GROUP LIFTS

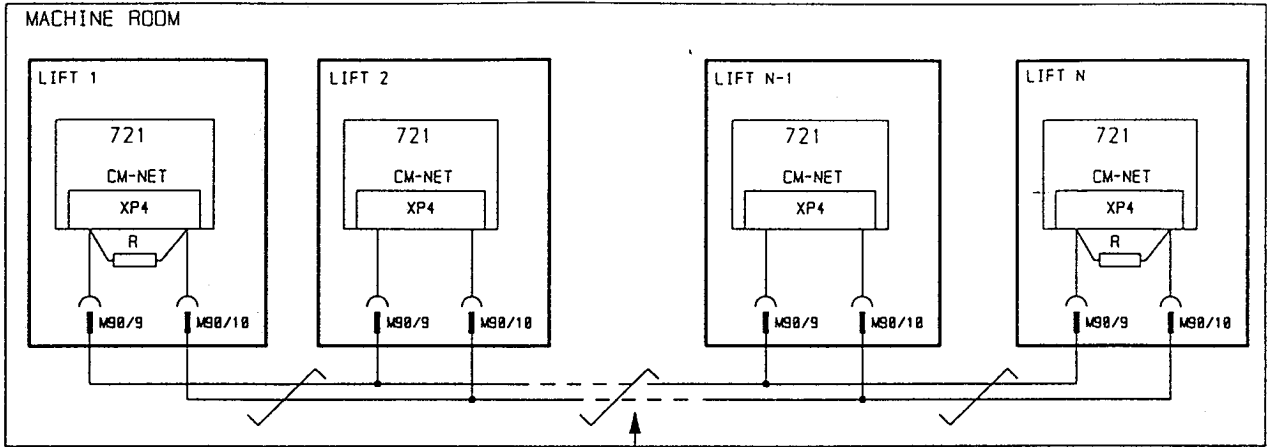

CABLE IS INCLUDED IN CONTROL PANEL DELIVERY

MONITORING SYSTEM

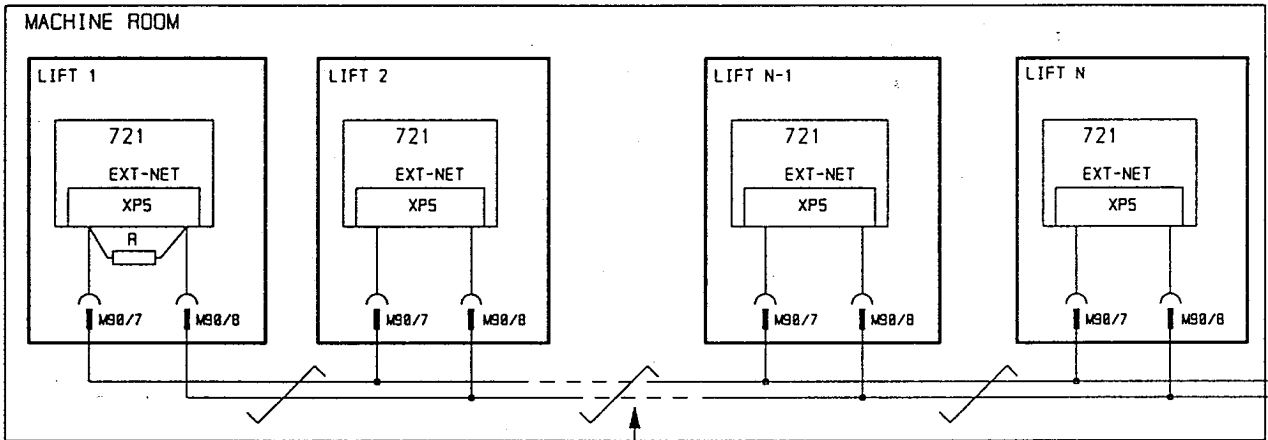

CABLE IS INCLUDED IN CONTROL PANEL DELIVERY

R = TERMINATION RESISTOR (120Ω MIN 0.25 W).
CONNECTED AT THE BEGINNING AND END OF THE CAN-NETWORK.
SEE DRAWING FOR DETAILS.

NOTE! MAX 10 ELEVATORS
PER WORKSTATION

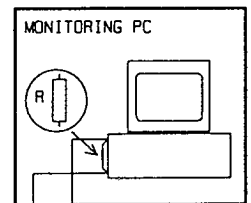

LOCAL SUPPLY
AWG 18, TWISTED 4x/FOOT

DESIGNER O. LIGNELL	DRN. OPL	PRODUCT CODE TMS508	LANGUAGE EN	M-FILM
DATE 94/28	DEPT. HEC	CHD.	APPO.	ISSUE



CONNECTION OF THE COMMON MEMORY CABLES

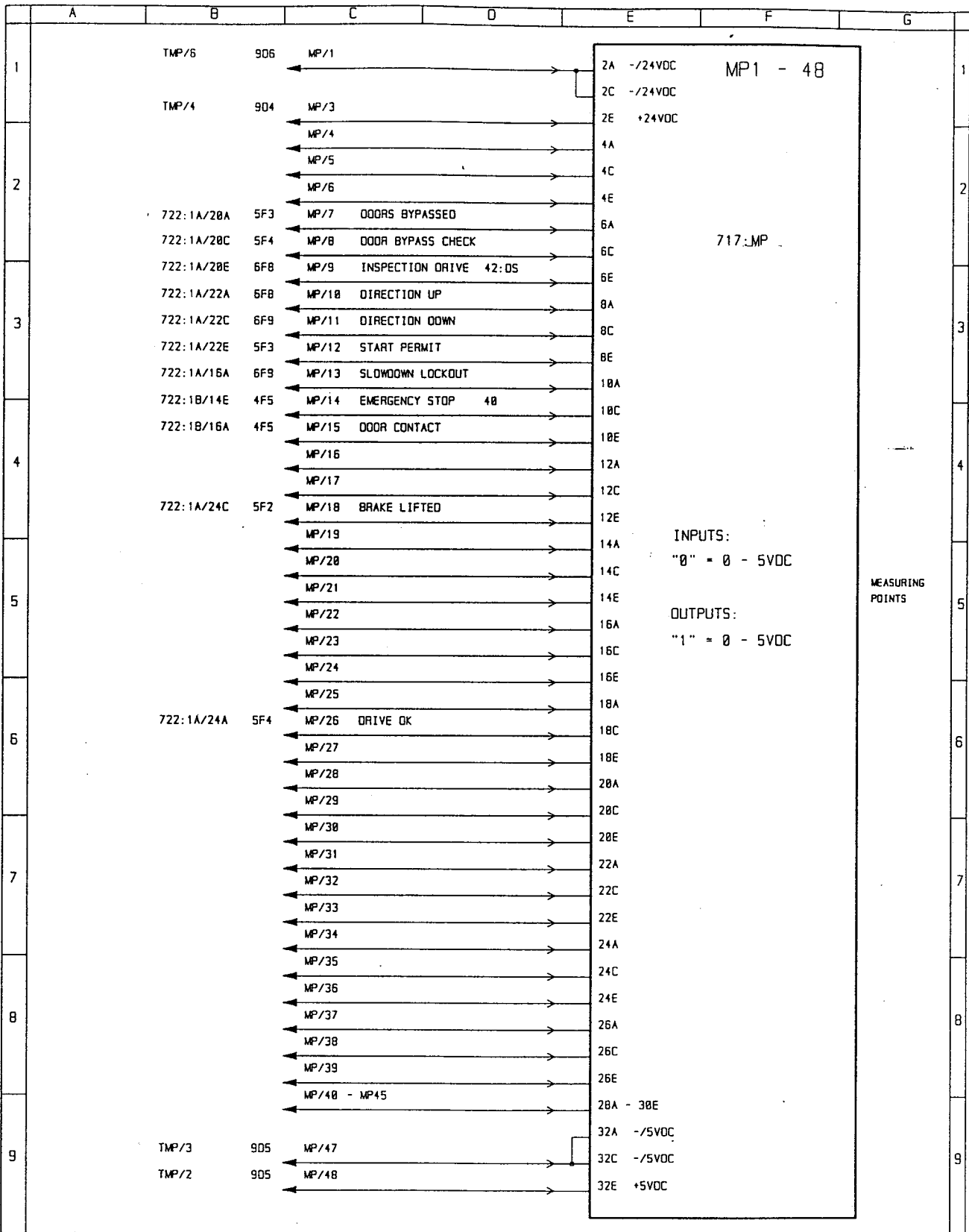

DESIGNER	O. LIGNELL	DRN.	OPL	PRODUCT CODE	TWS600 SCO	LANGUAGE	EN	M-FILM
DATE	94/28	DEPT.	HEC	CHK.	APPO.	REG.		ISSUE
MEASURING POINTS								
KONE								
ISSUE	ALTERNATION	DATE	DRN.	APPO.	M-FILM	TWIN COPY		

CIRCUIT DIAGRAM 508610E29 PAGE 21

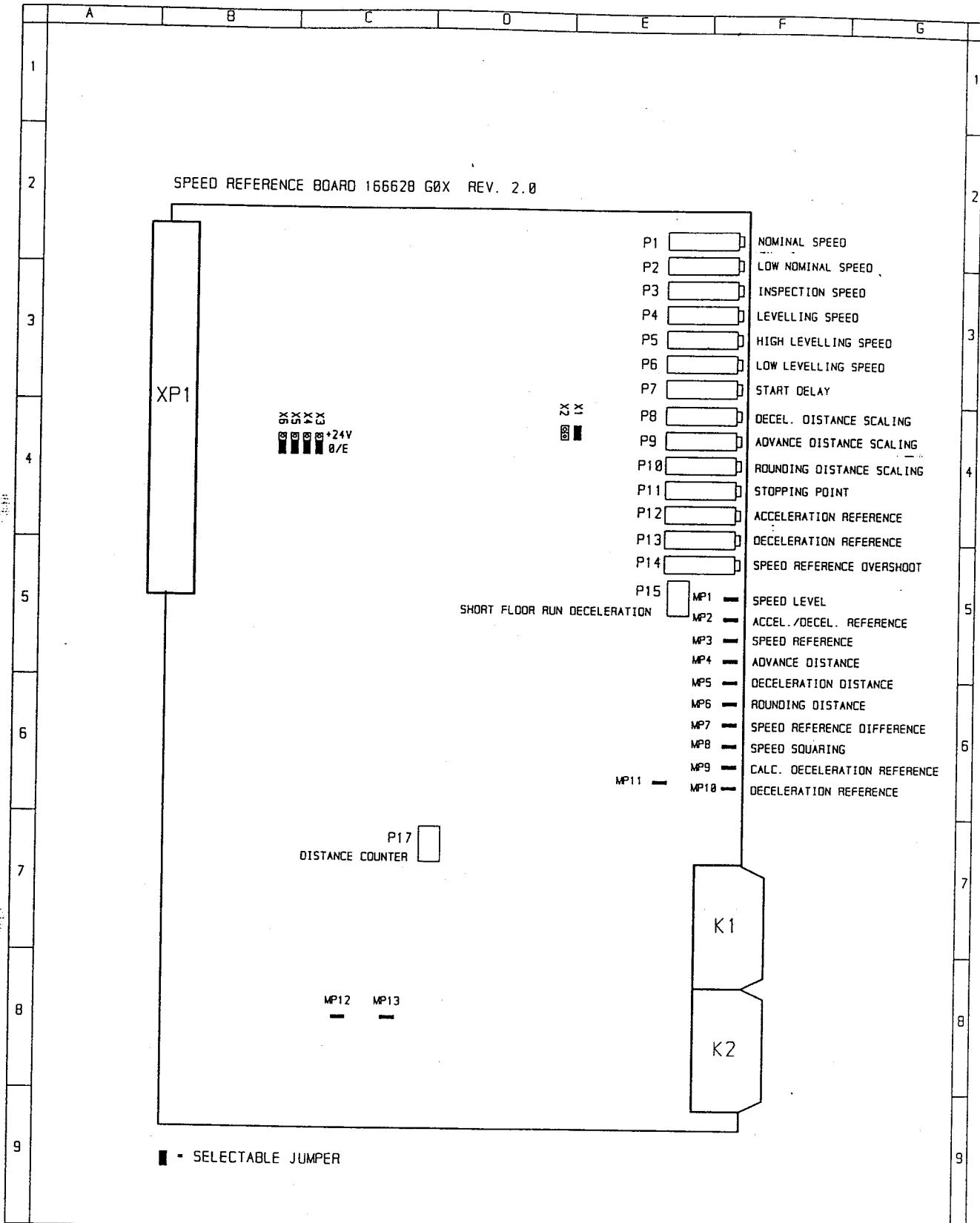

DESIGNER	O. LIGNELL	DRW.	DPL	PRODUCT CODE	TMS600 SCD	LANGUAGE	EN	M-FILM
DATE	94/28	DEPT.	HEC	CHD.	APPO.	REG.	ISSUE	
KONE								
CODING OF SPEED REFERENCE BOARD								
ISSUE	ALTERNATION	DATE	DRW.	APPO.	M-FILM	THINK COPY		
CIRCUIT DIAGRAM						508610E37		PAGE 22